



CENTRO INTERNACIONAL DE ESTUDOS  
DE DOUTORAMENTO E AVANZADOS  
DA USC (CIEDUS)

TESE DE DOUTORAMENTO

**WITTEN'S PERTURBATION  
AND LEFSCHETZ FORMULA  
ON SINGULAR SPACES**

Carlos Luis Franco Sanmartín

ESCOLA DE DOUTORAMENTO INTERNACIONAL  
PROGRAMA DE DOUTORAMENTO EN MATEMÁTICAS

SANTIAGO DE COMPOSTELA

ANO 2019



## DECLARACIÓN DO AUTOR DA TESE

### Witten's Perturbation and Lefschetz Formula on Singular Spaces

D. Carlos Luis Franco Sanmartín

Presento a miña tese, seguindo o procedemento adecuado ao Regulamento, e declaro que:

- 1) A tese abarca os resultados da elaboración do meu traballo.
- 2) No seu caso, na tese faise referencia ás colaboracións que tivo este traballo.
- 3) A tese é a versión definitiva presentada para a súa defensa e coincide coa versión enviada en formato electrónico.
- 4) Confirmo que a tese non incorre en ningún tipo de plaxio doutros autores nin de traballos presentados por min para a obtención doutros títulos.

*En Santiago de Compostela, 2 de maio de 2019*

Asdo. Carlos Luis Franco Sanmartín





## AUTORIZACIÓN DO DIRECTOR DA TESE

### **Witten's Perturbation and Lefschetz Formula on Singular Spaces**

D. Jesús Antonio Álvarez López

INFORMA:

*Que a presente tese se corresponde co traballo realizado por D. Carlos Luis Franco Sanmartín, baixo a miña dirección, e autorizo a súa presentación, considerando que reúne os requisitos esixidos no Regulamento de Estudos de Doutoramento da USC, e que como director desta non incorro nas causas de abstención establecidas na lei 40/2015.*

*En Santiago de Compostela, 2 de maio de 2019*

Asdo. Jesús Antonio Álvarez López



# Contents

---

|  |           |
|--|-----------|
| <b>Preface</b>   | <b>v</b>  |
| <b>1 Introduction</b>  | <b>1</b>  |
| 1.1 Ideal boundary conditions of the de Rham complex . . . . . | 1         |
| 1.2 Stratified spaces . . . . .                                | 2         |
| 1.3 General adapted metrics . . . . .                          | 5         |
| 1.4 Relatively Morse functions . . . . .                       | 6         |
| 1.5 Lefschetz trace formula . . . . .                          | 8         |
| 1.6 Main theorems . . . . .                                    | 9         |
| 1.7 Applications to intersection homology . . . . .            | 10        |
| 1.8 Ideas of the proofs . . . . .                              | 14        |
| 1.9 Some open problems . . . . .                               | 15        |
| 1.10 Dunkl Harmonic Oscillator . . . . .                       | 16        |
| <b>2 Witten's Perturbation on Strata</b>                       | <b>23</b> |
| 2.1 Preliminaries . . . . .                                    | 25        |
| 2.1.1 Products of cones . . . . .                              | 25        |
| 2.1.2 General adapted metrics . . . . .                        | 27        |
| 2.1.3 Relatively Morse functions . . . . .                     | 28        |
| 2.1.4 Hilbert and elliptic complexes . . . . .                 | 29        |
| 2.2 Two simple types of elliptic complexes . . . . .           | 31        |
| 2.2.1 An elliptic complex of length one . . . . .              | 31        |
| 2.2.2 An elliptic complex of length two . . . . .              | 34        |
| 2.2.3 The wave operator . . . . .                              | 46        |
| 2.3 Witten's perturbation on a cone . . . . .                  | 47        |
| 2.3.1 Witten's perturbation . . . . .                          | 47        |
| 2.3.2 De Rham operators on a cone . . . . .                    | 48        |
| 2.3.3 Witten's perturbation on a cone . . . . .                | 50        |
| 2.4 Splitting of the Witten's complex on a cone . . . . .      | 51        |
| 2.4.1 Spectral decomposition on the link of the cone . . . . . | 51        |

|          |   |            |
|----------|---|------------|
| 2.4.2    | Subcomplexes of length one . . . . .  | 51         |
| 2.4.3    | Subcomplexes of length two . . . . .  | 53         |
| 2.4.4    | Splitting into subcomplexes . . . . .   | 55         |
| 2.5      | Relatively local model of the Witten's perturbation . . . . .   | 58         |
| 2.6      | Proof of Theorem 1.6.1 . . . . .  | 60         |
| 2.7      | Functional calculus . . . . .   | 60         |
| 2.8      | The wave operator . . . . .   | 60         |
| 2.9      | Proof of Theorem 1.6.2 . . . . .  | 62         |
| <b>3</b> | <b>Lefschetz trace formula</b>  | <b>65</b>  |
| 3.1      | Reduction to the contribution from the fixed points . . . . .   | 66         |
| 3.2      | Lefschetz trace formula on a cone . . . . .   | 68         |
| 3.3      | Contribution from the singular fixed points . . . . .   | 71         |
| <b>4</b> | <b>Dunkl Harmonic Oscillator</b>  | <b>73</b>  |
| 4.1      | Preliminaries . . . . .   | 74         |
| 4.2      | The sesquilinear form $t$ . . . . .   | 76         |
| 4.3      | Scalar products of mixed generalized Hermite functions . . . . .  | 90         |
| 4.3.1    | Case where $\sigma = \theta \neq \tau$ and $\tau - \sigma \notin -\mathbb{N}$ . . . . .                     | 91         |
| 4.3.2    | Case where $\sigma \neq \theta \neq \tau$ and $\sigma - \theta, \tau - \theta \notin -\mathbb{N}$ . . . . . | 94         |
| 4.4      | The sesquilinear form $t'$ . . . . .  | 99         |
| 4.4.1    | Case where $\sigma = \theta = \tau$ . . . . .   | 99         |
| 4.4.2    | Case where $\sigma = \theta \neq \tau$ and $\tau - \sigma \notin -\mathbb{N}$ . . . . .                     | 99         |
| 4.4.3    | Case where $\sigma \neq \theta = \tau$ and $\sigma - \theta \notin -\mathbb{N}$ . . . . .                   | 100        |
| 4.4.4    | Case where $\sigma \neq \theta = \tau + 1$ and $\sigma - \tau - 1 \notin -\mathbb{N}$ . . . . .             | 101        |
| 4.4.5    | Case where $\sigma \neq \theta \neq \tau$ and $\sigma - \theta, \tau - \theta \notin -\mathbb{N}$ . . . . . | 103        |
| 4.4.6    | Proof of Theorem 1.10.3 . . . . .   | 104        |
| 4.5      | A preliminary estimate . . . . .  | 106        |
| 4.5.1    | Statement . . . . .   | 106        |
| 4.5.2    | Proof of Lemma 4.5.1 . . . . .  | 107        |
| 4.6      | The main estimates . . . . .  | 121        |
| 4.7      | Operators induced on $\mathbb{R}_+$ . . . . .   | 126        |
|          | <b>Appendix</b>   | <b>132</b> |
| <b>A</b> | <b>Preliminaries on Stratified Spaces and Global Analysis</b>   | <b>133</b> |
| A.1      | Stratified Spaces . . . . .   | 133        |
| A.1.1    | Thom-Mather stratifications . . . . .   | 133        |
| A.1.2    | Products of stratifications . . . . .   | 135        |
| A.2      | Some Results of Global Analysis . . . . .   | 136        |

|  |            |
|--|------------|
| <b>Resumo</b>  | <b>139</b> |
| 1 Condicións de fronteira ideal do complexo de de Rham . . . . . | 140        |
| 2 Espazos estratificados . . . . .                               | 141        |
| 3 Métricas adaptadas xerais . . . . .                            | 144        |
| 4 Funcións de rel-Morse . . . . .                                | 145        |
| 5 Fórmula da traza de Lefschetz . . . . .                        | 147        |
| 6 Teoremas principais . . . . .                                  | 148        |
| 7 Aplicacións a homoloxía intersección . . . . .                 | 150        |
| 8 Ideas principais das demostracións . . . . .                   | 152        |
| 9 Problemas abertos . . . . .                                    | 153        |
| 10 Oscilador harmónico de Dunkl . . . . .                        | 154        |
| <b>Bibliography</b>  | <b>161</b> |





# Preface

---

The objects studied in this thesis are Thom-Mather stratified spaces. This concept was introduced by René Thom and John Mather in 1970. Afterwards, these stratifications were deeply studied by Mark Goresky and Robert MacPherson, using intersection homology.

By definition, Thom-Mather stratified spaces admit a partition into smooth manifolds called strata, which in general have different dimensions. The strata are glued under certain technical conditions involving conic bundles. This gives rise to a local description of these spaces using conical charts, which generalize the usual charts on smooth manifolds. Moreover several kinds of metrics can be defined on the strata of Thom-Mather stratified spaces: general adapted metrics, adapted metrics and adapted metrics of conic type.

The principal aims of this research on Thom-Mather stratifications are geometrical and topological results, generalizing or adapting to this setting classical theorems and properties of manifolds with boundary. Some differential operators can be considered on strata, acting on the corresponding spaces of differential forms, or over smooth sections of other vector bundles. Their study is a very powerful technique to obtain many properties of stratified spaces. Thus Functional Analysis and Partial Differential Equations, particularly the heat equation and the wave equation, are fundamental tools in this field. The mathematical area that applies Operator Theory in order to obtain geometrical and topological results on manifolds and related objects is called Global Analysis.

Let us introduce the general setting that will be considered in this thesis, and which is explained with detail in Chapter 1. Let  $M$  be a stratum of a compact stratified space  $A$ , equipped with a general adapted metric  $g$ . This notion is slightly more general than the adapted metrics of Nagase and Brasselet-Hector-Saralegi. In particular,  $g$  has a general type, which is an extension of the type of adapted metrics. A condition on this general type is assumed, and then  $g$  is called good. We will consider the maximum/minimum ideal boundary condition,  $d_{\max/\min}$ , of the compactly supported de Rham complex on  $M$ , in the sense of Brüning-Lesch. Let  $H_{\max/\min}^*(M)$  and  $\Delta_{\max/\min}$  denote the cohomology and Laplacian of  $d_{\max/\min}$ . The first main theo-

rem of this thesis states that  $\Delta_{\max/\min}$  has a discrete spectrum satisfying a weak form of the Weyl's asymptotic formula. The second main theorem is a version of Morse inequalities using  $H_{\max/\min}^*(M)$  and what we call rel-Morse functions. A key ingredient of the proofs of both theorems is a version for  $d_{\max/\min}$  of the Witten's perturbation of the de Rham complex. This is a method to show Morse inequalities on manifolds with an analytic and physical point of view, which became very powerful in further applications. The arguments to prove both theorems are included in Chapter 2. The third main theorem of this thesis is a version of Lefschetz trace formula for stratified spaces with isolated singularities, proved in Chapter 3, where the Witten's perturbation also plays a key role. Another essential ingredient to get all of these results is certain perturbation of the Dunkl harmonic oscillator, studied in Chapter 4.

The condition on  $g$  to be good is general enough in the following sense. Assume that  $A$  is a stratified pseudomanifold with regular stratum  $M$ . Consider its intersection homology  $I^{\bar{p}}H_*(A)$  with perversity  $\bar{p}$ ; in particular, the lower and upper middle perversities are denoted by  $\bar{m}$  and  $\bar{n}$ , respectively. Then, for any perversity  $\bar{p} \leq \bar{m}$ , there is an associated good adapted metric on  $M$  satisfying the Nagase isomorphism  $H_{\max}^r(M) \cong I^{\bar{p}}H_r(A)^*$  ( $r \in \mathbb{N}$ ). If  $M$  is oriented and  $\bar{p} \geq \bar{n}$ , we also get  $H_{\min}^r(M) \cong I^{\bar{p}}H_r(A)$ . Thus the version of Morse inequalities and Lefschetz trace formula presented in this thesis can be described in terms of  $I^{\bar{p}}H_*(A)$ .

---

# Chapter 1

## Introduction

---

### Contents

|             |   |           |
|-------------|---|-----------|
| <b>1.1</b>  | <b>Ideal boundary conditions of the de Rham complex</b> | <b>1</b>  |
| <b>1.2</b>  | <b>Stratified spaces</b>                                | <b>2</b>  |
| <b>1.3</b>  | <b>General adapted metrics</b>                          | <b>5</b>  |
| <b>1.4</b>  | <b>Relatively Morse functions</b>                       | <b>6</b>  |
| <b>1.5</b>  | <b>Lefschetz trace formula</b>                          | <b>8</b>  |
| <b>1.6</b>  | <b>Main theorems</b>                                    | <b>9</b>  |
| <b>1.7</b>  | <b>Applications to intersection homology</b>            | <b>10</b> |
| <b>1.8</b>  | <b>Ideas of the proofs</b>                              | <b>14</b> |
| <b>1.9</b>  | <b>Some open problems</b>                               | <b>15</b> |
| <b>1.10</b> | <b>Dunkl Harmonic Oscillator</b>                        | <b>16</b> |

## 1.1 Ideal boundary conditions of the de Rham complex

The following usual notation is used for a densely defined linear operator  $T$  in a Hilbert space. Its domain and range are denoted by  $D(T)$  and  $R(T)$ . If  $T$  is essentially self-adjoint, its closure is denoted by  $\overline{T}$ . If  $T$  is self-adjoint, its *smooth core* is  $D^\infty(T) := \bigcap_{m=1}^\infty D(T^m)$ , and its spectrum is denoted by  $\sigma(T)$ .

A *Hilbert complex*  $(D, \mathbf{d})$  is a differential complex of finite length given by a densely defined closed operator  $\mathbf{d}$  in a graded separable Hilbert space  $\mathfrak{H}$  [15]. Then the operator  $\mathbf{D} = \mathbf{d} + \mathbf{d}^*$ , with  $D(\mathbf{D}) = D(\mathbf{d}) \cap D(\mathbf{d}^*)$ , is self-adjoint in  $\mathfrak{H}$ , and therefore the *Laplacian*  $\Delta = \mathbf{D}^2 = \mathbf{d}\mathbf{d}^* + \mathbf{d}^*\mathbf{d}$  is also self-adjoint. Moreover  $D^\infty(\Delta)$  is a subcomplex of  $(D, \mathbf{d})$  with the same homology [15, Theorem 2.12]; it may be also said that  $D^\infty(\Delta)$  is the *smooth core* of  $\mathbf{d}$ .

The above notion is applied here in the following case. For a Riemannian manifold  $M$ , let  $\Omega_0(M)$  be the space of compactly supported differential forms, and  $L^2\Omega(M)$  the graded Hilbert space of square integrable differential forms. Let  $d$  and

$\delta$  be the de Rham derivative and coderivative acting on  $\Omega_0(M)$ , and let  $D = d + \delta$  and  $\Delta = D^2 = d\delta + \delta d$  (the Laplacian). Every Hilbert complex extension  $\mathbf{d}$  of  $d$  in  $L^2\Omega(M)$  is called an *ideal boundary condition (i.b.c.)* [15], giving rise to self-adjoint extensions  $\mathbf{D}$  and  $\mathbf{\Delta}$  of  $D$  and  $\Delta$  in  $L^2\Omega(M)$ . There exists a maximum/minimum i.b.c.,  $d_{\max} = \delta^*$  and  $d_{\min} = \bar{d}$ , inducing self-adjoint extensions  $D_{\max/\min}$  and  $\Delta_{\max/\min}$  of  $D$  and  $\Delta$ . If  $M$  is oriented, then  $\Delta_{\max}$  corresponds to  $\Delta_{\min}$  by the Hodge star operator. The corresponding cohomologies,  $H_{\max/\min}(M)$ , are quasi-isometric invariants of  $M$ ; for instance,  $H_{\max}(M)$  is the usual  $L^2$ -cohomology  $H_{(2)}(M)$  [18]. They give rise to versions of Betti numbers and Euler characteristic,  $\beta_{\max/\min}^r = \beta_{\max/\min}^r(M)$  and  $\chi_{\max/\min} = \chi_{\max/\min}(M)$  (assuming finite dimension of the corresponding cohomologies). These concepts can indeed be defined for arbitrary elliptic complexes [15]. It is well known that  $d_{\min} = d_{\max}$  if  $M$  is complete. Thus considering an i.b.c. becomes interesting when  $M$  is not complete. For example, if  $M$  is the interior of a compact Riemannian manifold  $N$  with  $\partial N \neq \emptyset$ , then  $d_{\max/\min}$  is defined by taking absolute/relative boundary conditions. With more generality, we will assume that  $M$  is a stratum of a compact stratified space  $A$  [49, 50, 67, 69], equipped with a generalization of the adapted metrics considered in [13, 53, 54]. As it will be seen, we can assume  $\bar{M} = A$  if desired (it can be said that  $M$  is the *regular stratum* in this case).

## 1.2 Stratified spaces

Roughly speaking, a (*Thom-Mather*) *stratified space* (or *stratification*) is a Hausdorff, locally compact and second countable space  $A$  equipped with a partition into  $C^\infty$  manifolds (the *strata*), satisfying certain conditions [49, 67]. In particular, an order relation on the family of strata is defined by declaring  $X \leq Y$  when  $X \subset \bar{Y}$ . With respect to this ordering, the maximum length of chains of strata less or equal than a stratum  $X$  is called the *depth* of  $X$ . The supremum of the strata depth is called the *depth* of  $A$ , denoted  $\text{depth } A$ . The precise definition and needed preliminaries are collected in Appendix A.1.1. Here we just describe how the strata of  $A$  fit together, describing also *morphisms/isomorphisms* of stratifications, and, in particular, the group of *automorphisms*,  $\text{Aut}(A)$ . We proceed by induction on its depth. If  $\text{depth } A = 0$ , then  $A$  is just a  $C^\infty$  manifold, and  $\text{Aut}(A)$  consists of its diffeomorphisms.

Now, given any  $k \in \mathbb{Z}_+$ , assume that any stratified space  $L$  is described if  $\text{depth } L < k$ , as well as  $\text{Aut}(L)$ . If  $L$  is compact, the *cone* with *link*  $L$  is  $c(L) = (L \times [0, \infty)) / (L \times \{0\})$ , whose *vertex* is the point  $* = L \times \{0\} \in c(L)$ . Let  $L'$  be another compact stratification of  $\text{depth} < k$ , and  $\phi : L \rightarrow L'$  a morphism. Then let  $c(\phi) : c(L) \rightarrow c(L')$  be the map induced by  $\phi \times \text{id} : L \times [0, \infty) \rightarrow L' \times [0, \infty)$ ; in

particular, we get the group  $c(\text{Aut}(L)) = \{c(\phi) \mid \phi \in \text{Aut}(L)\}$ . It is also declared that  $c(\emptyset) = \{*\}$ , for the empty stratification, and  $c(\emptyset) = \text{id}$ , for the empty map. The cone  $c(L)$  is used as a model stratified space of depth  $k$  if  $L$  is of depth  $k - 1$ , whose strata are  $\{*\}$  and the manifolds  $Y \times \mathbb{R}_+$  for strata  $Y$  of  $L$ . The second factor projection  $L \times [0, \infty) \rightarrow [0, \infty)$  defines a  $c(\text{Aut}(L))$ -invariant function  $\rho : c(L) \rightarrow [0, \infty)$ , called the *radial function*. The restrictions of  $\rho$  to the strata are  $C^\infty$ . A *conic bundle* is a fiber bundle  $T$  over a manifold  $X$  with typical fiber  $c(L)$  and structural group  $c(\text{Aut}(L))$ . Then  $\rho$  induces a *radial function* on  $T$ , also denoted by  $\rho$ , and the vertex of  $c(L)$  defines the *vertex section* of  $T$ , whose image is identified with  $X$ . Moreover the stratified structure defined on  $c(L)$  can be used to define a stratified structure on  $T$ , where  $X$  becomes the *vertex stratum*.

For any stratification  $A$  of depth  $k$ , every stratum  $X$  has an open neighborhood (a *tube* representative) that is isomorphic to an open neighborhood of  $X$  in some conic bundle  $T_X$  over  $X$  (with the obvious restrictions of stratified structures to open subsets). The typical fiber of  $T_X$  is of the form  $c(L_X)$  for some compact stratification  $L_X$  (the *link* of  $X$ ) with depth  $L_X < \text{depth } A$ . The vertex and radial function of  $c(L_X)$  are denoted by  $*_X$  and  $\rho_X$ . Two such neighborhoods of  $X$  represent the same *tube* if their structure is equal on some smaller neighborhood of  $X$ . Note that  $X$  is open in  $A$  if and only if  $L_X = \emptyset$ .

Finally, a (*smooth*) *morphism* between two stratifications is a continuous map sending every stratum to another stratum, whose restrictions to the strata are  $C^\infty$ , and whose restrictions to small enough tube representatives are restrictions of conic bundle morphisms (see Appendix A.1.1). Then *isomorphisms* and *automorphisms* of stratifications have the obvious meaning. This completes the description because the depth is locally finite by the local compactness.

The (topological) dimension of a stratification  $A$  equals the supremum of the dimensions of its strata. It may be infinite, but it is locally finite. The *codimension* of a stratum  $X$  is  $\dim A - \dim X$ . The main results of this thesis assume that the stratification is compact, but non-compact stratifications will be also used in the proofs. In any case, only finite dimensional stratifications will be considered. If the above description of  $A$  is modified by requiring that, at every inductive step, only stratifications with no strata of codimension 1 are used, then  $A$  is called a *stratified pseudomanifold*.

A locally closed subset  $B \subset A$  is called a *substratification* of  $A$  if the restrictions of the strata and tubes of  $A$  to  $B$  define a stratified structure on  $B$  (see Appendix A.1.1). For instance,  $A$  can be restricted to any open subset, to any locally closed union of strata, and to the closure of any stratum. If moreover there are tube representatives of  $A$  whose restrictions to  $B$  have the same fibers over points of  $B$ , then  $B$  is called *saturated*.

Let  $x$  be a point of a stratum  $X$  of dimension  $m_X$  in a stratification  $A$ . A local trivialization of  $T_X$  on some open neighborhood  $U$  of  $x$  defines a *chart*  $O \equiv O'$  of  $A$  for some open  $O' \subset \mathbb{R}^{m_X} \times c(L_X)$ . We can assume  $O' = U' \times c_\epsilon(L_X)$ , where  $U'$  is some open neighborhood of 0 in  $\mathbb{R}^{m_X}$  and  $c_\epsilon(L_X)$  is the subset of  $c(L_X)$  defined by the condition  $\rho_X < \epsilon$ , for some  $\epsilon > 0$ . This chart is *centered* at  $x$  if  $x \equiv (0, *_{X}) \in O'$ . The corresponding concept of *atlas* has the obvious meaning. These concepts can be generalized as follows. Any finite product of stratifications has a non-canonical stratified structure (see Appendix A.1.2); in particular, any finite product of cones is isomorphic to a cone [5, Lemma 3.8]. Moreover  $\text{Aut}(P) \times \text{Aut}(Q)$  is canonically injected in  $\text{Aut}(P \times Q)$  for stratifications  $P$  and  $Q$ . Thus it makes sense to consider a decomposition  $c(L_X) \cong \prod_{i=1}^{a_X} c(L_{X,i})$  ( $a_X \in \mathbb{N}$ ), for compact stratifications  $L_{X,i}$ . The vertex and radial function of every  $c(L_{X,i})$  are denoted by  $*_{X,i}$  and  $\rho_{X,i}$ . Then we can also consider *general tube* representatives given by bundles  $T_X$  with typical fibers  $\prod_{i=1}^{a_X} c(L_{X,i})$  and structural groups  $\prod_{i=1}^{a_X} c(\text{Aut}(L_{X,i}))$ . This gives rise to a *general chart*  $O \equiv O'$  around  $x$  for some open  $O' \subset \mathbb{R}^{m_X} \times \prod_{i=1}^{a_X} c(L_{X,i})$ , which is *centered* at  $x$  if  $x \equiv (0, *_{X,1}, \dots, *_{X,a_X}) \in O'$ . As above, we can assume  $O' = U' \times \prod_{i=1}^{a_X} c_\epsilon(L_{X,i})$  for some  $\epsilon > 0$ . Let  $\rho_{X,0}$  denote the norm function on  $\mathbb{R}^{m_X}$ . The function  $\rho = (\rho_{X,0}^2 + \dots + \rho_{X,a_X}^2)^{1/2}$  is called the *radial* function of  $\mathbb{R}^{m_X} \times \prod_{i=1}^{a_X} c(L_{X,i})$ , even though, when  $m_X = 0$ ,  $\rho$  is not the radial function of any cone structure on  $\prod_{i=1}^{a_X} c(L_{X,i})$  [5, Example 3.6 and Proof of Lemma 3.8]. A collection of general charts covering  $A$  is called a *general atlas*.

*Example 1.2.1.* Figure 1.2.1 (taken from [35]) illustrates a compact stratification with four strata. It is constructed by “choking” a meridian section of a usual torus into a point  $x$  (0-dimensional stratum), and covering its hole with a disk (2-dimensional stratum). The border line between the torus and the disk is a 1-dimensional stratum. The regular part of the torus is another bidimensional stratum. There is no dense stratum, so we cannot choose a regular one. Notice that two charts are indicated in the picture, taken around the points  $x$  and  $y$ , respectively. The chart centered at  $x$  has trivial Euclidean factor; whereas the conic factor of the chart centered at  $y$  has a link consisting on three points.

We can suppose that the strata of  $A$  are connected (see Appendix A.1.1). Fix a stratum  $M$  of dimension  $n$  in  $A$ . Since the stratified structure of  $A$  can be restricted to  $\overline{M}$ , we can also assume without loss of generality that  $\overline{M} = A$  (any other stratum is  $< M$ ); in particular,  $\text{depth } A = \text{depth } M$  and  $\dim A = n$ . It is said that  $A$  is an *orientable* stratification if  $M$  is an orientable manifold. With the above notation, for a chart  $O \equiv O'$  centered at  $x$ , we get  $M \cap O \equiv M' \cap O'$ , where  $M' = \mathbb{R}^{m_X} \times N \times \mathbb{R}_+$  for some dense stratum  $N$  on  $L_X$ . In the case of a general chart  $O \equiv O'$  centered at  $x$ , we have  $M \cap O \equiv M' \cap O'$  for  $M' = \mathbb{R}^{m_X} \times \prod_{i=1}^{a_X} (N_i \times \mathbb{R}_+)$ , where every  $N_i$

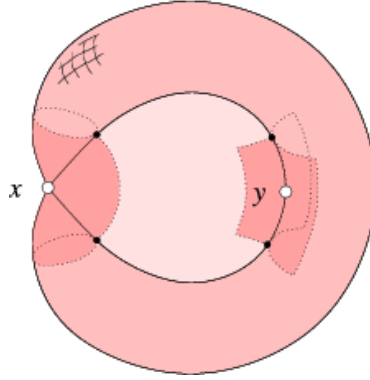

Figure 1.2.1: Charts on a compact stratification

is some dense stratum of  $L_{X,i}$ . We will use the notation  $k_{X,i} = \dim N_i + 1$ .

### 1.3 General adapted metrics

A *general adapted metric*  $g$  on  $M$  is defined by induction on the depth of  $M$ . It is any (Riemannian) metric if  $\text{depth } M = 0$ . Now, assume that  $\text{depth } M > 0$  and general adapted metrics are defined for lower depth. Given any general chart  $O \equiv O'$  as above, take any general adapted metric  $\tilde{g}_i$  on every  $N_i$  ( $\text{depth } N_i < \text{depth } M$ ), and let  $g_i = \rho_{X,i}^{2u_{X,i}} \tilde{g}_i + (d\rho_{X,i})^2$  on  $N_i \times \mathbb{R}_+$  for some  $u_{X,i} > 0$ . Let also  $g_0$  be the Euclidean metric on  $\mathbb{R}^{m_X}$ . Then  $g$  is a *general adapted metric* if, via any such general chart,  $g|_O$  is quasi-isometric to  $(\sum_{i=0}^{a_X} g_i)|_O$ . In this case, the mapping  $X \mapsto u_X := (u_{X,1}, \dots, u_{X,a_X}) \in \mathbb{R}_+^{a_X}$  ( $X < M$ ) is called the *general type* of  $g$ . Such a general chart is called *compatible* with  $g$ , or with its general type.

Let us point out that a general metric does not completely determine its general type. For instance, suppose  $u_{X,i} = u_{X,j} = 1$  for indices  $i \neq j$ . Write  $c(L_{X,i}) \times c(L_{X,j}) \equiv c(L)$ , with radial function  $\rho$ , for some stratification  $L$ . Then  $N_i \times \mathbb{R}_+ \times N_j \times \mathbb{R}_+ \equiv N \times \mathbb{R}_+$  for some dense stratum  $N$  of  $L$ . Moreover there is a general adapted metric  $\tilde{g}$  on  $N$  such that  $g_i + g_j$  is quasi-isometric to  $\rho^2 \tilde{g} + (d\rho)^2$  via the above identity. Therefore we can omit  $u_{X,i}$  or  $u_{X,j}$  in  $u_X$ , obtaining a different type of  $g$ . This cannot be done if  $u_{X,i} = u_{X,j} \neq 1$  (Proposition 2.1.1).

If the above definition of general adapted metric is modified by requiring that, at every inductive step, the general type satisfies  $u_{X,i} \leq 1$  for all  $X < M$  and  $i = 1, \dots, a_X$ , then the general adapted metric is called *good* for the scope of this thesis. On the other hand, if the definition is modified by requiring at every inductive step that  $a_X = 1$  and  $u_X$  depends only on  $k := k_{X,1} = \text{codim } X$  for all  $X < M$ ,

then we get the *adapted metrics* considered in [13, 53, 54]. In this case, the general charts compatible with the general type are indeed charts. Writing  $u_k = u_X \equiv u_{X,1} \in \mathbb{R}_+$ , the condition on an adapted metric  $g$  to be good becomes  $u_k \leq 1$  for all  $k$ , at every inductive step of its definition. In [13, 53, 54], it is assumed that  $A$  is a stratified pseudomanifold, and then  $\hat{u} = (u_2, \dots, u_n)$  stands for the *type* of  $g$ . This  $\hat{u}$  is determined by  $g$ . In particular, if the definition is modified by taking  $u_k = 1$  for all  $k$  at every inductive step, we get the adapted metrics of *conic type* considered in [18–20]. Be alerted about the three slightly different terms used for the scope of this thesis: general adapted metrics, adapted metrics and adapted metrics of conic type. The class of (good) general adapted metrics is preserved by products, as well as the class of adapted metrics of conic type, but the class of adapted metrics does not have this property. The existence of general adapted metrics with any possible general type can be shown like in the case of adapted metrics [53, Lemma 4.3], [13, Appendix].

Like in [5], the term “relative(ly)” (or simply “rel-”) usually means that some condition is required in the intersection of  $M$  with small neighborhoods of the points in  $\overline{M}$ , or that some concept can be described using those intersections.

Let  $M$  be equipped with a general adapted metric  $g$ , with a general type  $X \mapsto u_X$  as above. The *rel-local metric completion*  $\widehat{M}$  of  $M$  consists of the points in the metric completion represented by Cauchy sequences that converge in  $\overline{M}$  ( $\widehat{M}$  is the metric completion of  $M$  if  $\overline{M}$  is compact). Figure 1.3.1 illustrates this concept. The limits of Cauchy sequences define a continuous map  $\lim : \widehat{M} \rightarrow \overline{M}$ . The following properties can be proved like in the case of conic metrics [5, Proposition 3.20-(i),(ii)].  $\widehat{M}$  has a unique stratified structure with connected strata so that  $\lim : \widehat{M} \rightarrow \overline{M}$  is a morphism whose restrictions to the strata are local diffeomorphisms. Moreover  $g$  is also a general adapted metric with respect to  $\widehat{M}$ .

## 1.4 Relatively Morse functions

A smooth function  $f$  on  $M$  is called *rel-admissible* when the functions  $f$ ,  $|df|$  and  $|\text{Hess } f|$  are rel-bounded. In this case,  $f$  may not have any continuous extension to  $\overline{M}$ , but it has a continuous extension to  $\widehat{M}$ . So it makes sense to say that  $x \in \widehat{M}$  is a *rel-critical point* of  $f$  when  $\liminf |df(y)| = 0$  as  $y \rightarrow x$  in  $\widehat{M}$  with  $y \in M$ . The set of rel-critical points of  $f$  is denoted by  $\text{Crit}_{\text{rel}}(f)$ . It is said that  $f$  is a *rel-Morse function* if it is rel-admissible and has the following description around every  $x \in \text{Crit}_{\text{rel}}(f)$ :

- there is a general chart  $O \equiv O'$  of  $\widehat{M}$ , centered at  $x$  and compatible with  $g$ , such that  $M \cap O \equiv M' \cap O'$  for  $M' = \mathbb{R}^{m_X} \times \prod_{i=1}^{a_X} (N_i \times \mathbb{R}_+)$ , where  $X$  is

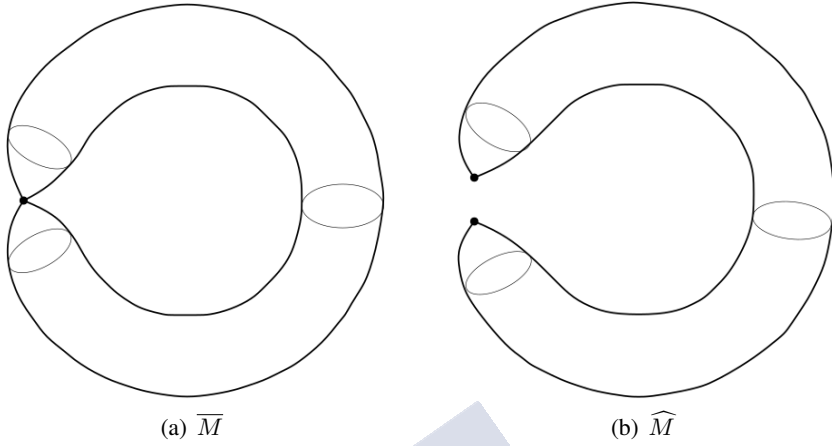
 Figure 1.3.1: The stratified space  $\widehat{M}$ .

the stratum of  $\widehat{M}$  containing  $x$ ; and

- $f|_{M \cap O} \equiv f(x) + \frac{1}{2}(\rho_+^2 - \rho_-^2)|_{M' \cap O'}$ , where  $\rho_{\pm}$  is the radial function of  $\mathbb{R}^{m_{\pm}} \times \prod_{i \in I_{\pm}} c(L_{X,i})$  for some expression  $m_X = m_+ + m_-$  ( $m_{\pm} \in \mathbb{N}$ ) and some partition of  $\{1, \dots, a_X\}$  into sets  $I_{\pm}$ .

This local condition is used instead of requiring that  $\text{Hess } f$  is “rel-non-degenerate” at the rel-critical points because a “rel-Morse lemma” is missing in this context. Moreover, for  $r = 0, \dots, n$ , let

$$\nu_{x, \max/\min}^r = \sum_{(r_1, \dots, r_{a_X})} \prod_{i=1}^{a_X} \beta_{\max/\min}^{r_i}(N_i), \quad (1.4.1)$$

where  $(r_1, \dots, r_{a_X})$  runs in the subset of  $\mathbb{N}^{a_X}$  determined by

$$\left. \begin{aligned} r &= m_- + \sum_{i=1}^{a_X} r_i + |I_-|, \\ r_i &< \frac{k_{X,i}-1}{2} + \frac{1}{2u_{X,i}} & \text{if } i \in I_+ \\ r_i &\geq \frac{k_{X,i}-1}{2} + \frac{1}{2u_{X,i}} & \text{if } i \in I_- \\ r_i &\leq \frac{k_{X,i}-1}{2} - \frac{1}{2u_{X,i}} & \text{if } i \in I_+ \\ r_i &> \frac{k_{X,i}-1}{2} - \frac{1}{2u_{X,i}} & \text{if } i \in I_- \end{aligned} \right\} \begin{array}{l} \text{for } \nu_{x, \max}^r, \\ \text{for } \nu_{x, \min}^r. \end{array} \quad (1.4.2)$$

When  $a_X = 0$  in (1.4.1), the singleton  $\mathbb{N}^0$  consists of the empty sequence, obtaining<sup>1</sup>  $\nu_{x, \max/\min}^r = \delta_{r, m_-}$  with the convention that the value of empty products is 1. Finally,

<sup>1</sup>Kronecker’s delta symbol is used.

let  $\nu_{\max/\min}^r = \sum_x \nu_{x, \max/\min}^r$  with  $x$  running in  $\text{Crit}_{\text{rel}}(f)$ . The notation  $\nu_{x, \max/\min}^r(f)$  and  $\nu_{\max/\min}^r(f)$  may be used if necessary. The existence of rel-Morse functions for general adapted metrics holds like in the case of adapted metrics [5, Proposition 4.9].

## 1.5 Lefschetz trace formula

Let  $A$  be a compact orientable stratification of dimension  $n$  with isolated singularities and equipped with a good adapted metric  $g$  over its regular part  $\text{reg}(A) = M$ . In particular, if  $n > 1$ ,  $A$  is an orientable stratified pseudomanifold with depth  $A = 1$ . Consider a morphism of stratifications  $\psi : A \rightarrow A$ . Recall that we assume that  $\psi|_M$  is a smooth map by definition of morphism (Section 1.2). Let  $\psi^*$  be the endomorphism of  $(\Omega(M), d)$  induced by  $\psi$ . Let also  $\text{Fix}(\psi)$  denote the set of fixed points of  $\psi$ .

Every singular point is a zero dimensional stratum of  $A$ . Then, for every  $q \in \text{sing}(A) = A \setminus M$ , there exists a chart

$$O_q \equiv O'_q = \{0\} \times c_{\epsilon_q}(L_q) \equiv c_{\epsilon_q}(L_q)$$

centered at  $q$  such that  $\text{depth } L_q = 0$  (see Section 1.2). This means that every link  $L_q$  is a compact smooth manifold. Moreover, this local structure around the singular points implies that, for every  $q \in \text{Fix}(\psi) \cap \text{sing}(A)$ , the morphism  $\psi$  satisfies

$$\psi(\rho, x) = (\rho F_q(\rho, x), G_q(\rho, x)) \tag{1.5.1}$$

in any such conic chart  $O_q \equiv c_{\epsilon_q}(L_q)$ . Here, the maps  $F_q : L_q \times [0, \epsilon_q) \rightarrow [0, \epsilon_q)$  and  $G_q : L_q \times [0, \epsilon_q) \rightarrow L_q$  are smooth up to zero.

It is said that:

- a point  $q \in \text{Fix}(\psi) \cap M$  is *simple* if  $\det(1 - T_q\psi) \neq 0$ .
- a point  $q \in \text{Fix}(\psi) \cap \text{sing}(A)$  is *simple* if for every  $x \in L_q$  it happens that  $F_q(0, x) \neq 1$  or  $G_q(0, x) \neq x$ .

The required conditions in the previous definition imply that the simple fixed points are isolated in  $\text{Fix}(\psi)$  (see an explanation for the singular case in [9, § 3]).

The following hypotheses will be assumed on  $\psi$ :

- (a) The morphism  $\psi$  fixes every singular point of  $A$ .
- (b) The set  $\text{Fix}(\psi)$  contains only simple fixed points.
- (c) For every  $q \in \text{sing}(A)$ , the maps  $F_q$  and  $G_q$  do not depend on  $\rho$  around  $q$ .

In particular, hypothesis (a) implies that  $\psi$  preserves the regular and the singular parts of  $A$ . Then, on every conic chart  $O_q \equiv c_{\epsilon_q}(L_q)$ , we have  $F_q(\rho, x) > 0$  for all  $\rho > 0$ . By (1.5.1), hypothesis (c) means that

$$\psi(\rho, x) = (\rho F_q(x), G_q(x))$$

on every small enough conic chart  $O_q \equiv c_{\epsilon_q}(L_q)$ .

The adapted metric  $g|_{O_q}$  is quasi-isometric to the metric  $\rho^{2u}\tilde{g}_q + (d\rho)^2$  on the manifold  $L_q \times (0, \epsilon_q)$ , where  $\tilde{g}_q$  is a Riemannian metric on  $L_q$  and  $0 < u \leq 1$ . There exists a *maximum/minimum Lefschetz number* associated to the morphism  $\psi$ , defined by

$$L_{\max/\min}(\psi) = \sum_{r=0}^n (-1)^r \operatorname{tr}(\psi^* \text{ on } H_{\max/\min}^r(M)). \quad (1.5.2)$$

## 1.6 Main theorems

The results stated in this section and the next one were published in [7], with the exception of the results about Lefschetz trace formula.

The following is the first main theorem of this thesis, where property (ii) is a weak version of the Weyl's asymptotic formula.

**Theorem 1.6.1.** *The following properties hold on any stratum of a compact stratification with a good general adapted metric:*

- (i)  $\Delta_{\max/\min}$  has a discrete spectrum,  $0 \leq \lambda_{\max/\min,0} \leq \lambda_{\max/\min,1} \leq \dots$ , where every eigenvalue is repeated according to its multiplicity.
- (ii)  $\liminf_k \lambda_{\max/\min,k} k^{-\theta} > 0$  for some  $\theta > 0$ .

The second main result is the following version of Morse inequalities for rel-Morse functions.

**Theorem 1.6.2.** *For any rel-Morse function on a stratum of dimension  $n$  of a compact stratification, equipped with a good general adapted metric, we have*

$$\sum_{r=0}^k (-1)^{k-r} \beta_{\max/\min}^r \leq \sum_{r=0}^k (-1)^{k-r} \nu_{\max/\min}^r \quad (0 \leq k < n),$$

$$\chi_{\max/\min} = \sum_{r=0}^n (-1)^r \nu_{\max/\min}^r.$$

The third main result is the following version of Lefschetz trace formula for stratified spaces with isolated singularities.

**Theorem 1.6.3.** *Consider an orientable compact stratification  $A$  with isolated singularities and equipped with a good adapted metric over its regular stratum  $M$ . Then, for any morphism  $\psi : A \rightarrow A$  satisfying hypothesis (a)–(c), we have*

$$L_{\max/\min}(\psi) = \sum_{q \in \text{Fix}(\psi) \cap M} \text{sign det}(1 - T_q\psi) + \sum_{q \in \text{sing}(A)} L(G_q).$$

Observe that  $L_{\max/\min}(\psi)$  does not depend on the chosen (maximum or minimum) ideal boundary condition.

In the case of adapted metrics of conic type, the previous results have been already obtained:

- Theorem 1.6.1-(i) is essentially due to Cheeger [18, 19] (see also [1, 2, 5]).
- Theorem 1.6.1-(ii) was proved by Álvarez López and Calaza [5].
- Theorem 1.6.2 was proved by Álvarez López and Calaza [5], and also by Ludwig [48] (with more restrictive conditions but stronger consequences).
- A version of Theorem 1.6.3 was proved by Francesco Bei [9] (with more restrictive conditions).

Other developments of elliptic theory on strata were made in [1, 2, 16, 23, 40, 42, 65], all of them using adapted metrics of conic type. The main novelty of this thesis is the extension of the elliptic theory on strata to the wider class of good general adapted metrics, including good adapted metrics.

## 1.7 Applications to intersection homology

Consider now the case where  $A$  is a stratified pseudomanifold, and therefore  $M$  is its regular stratum. Let  $I^{\bar{p}}H_*(A)$  denote its intersection homology with perversity  $\bar{p}$  [32, 33], taking real coefficients. Let  $\beta_r^{\bar{p}} = \beta_r^{\bar{p}}(A)$  and  $\chi^{\bar{p}} = \chi^{\bar{p}}(A)$  denote the versions of Betti numbers and Euler characteristic for  $I^{\bar{p}}H_*(A)$ . Every perversity can be considered as a sequence  $\bar{p} = (p_2, p_3, \dots)$  in  $\mathbb{N}$  satisfying  $p_2 = 0$  and  $p_k \leq p_{k+1} \leq p_k + 1$ . For example, the zero perversity is  $\bar{0} = (0, 0, \dots)$ , the top perversity is  $\bar{t} = (0, 1, 2, \dots)$  ( $t_k = k - 2$ ), the lower middle perversity is  $\bar{m} = (0, 0, 1, 1, 2, 2, 3, \dots)$  ( $m_k = \lfloor \frac{k}{2} \rfloor - 1$ ), and the upper middle perversity is  $\bar{n} = (0, 1, 1, 2, 2, 3, 3, \dots)$  ( $n_k = \lceil \frac{k}{2} \rceil - 1$ ). Recall also that two perversities  $\bar{p}$  and  $\bar{q}$  are called complementary if  $\bar{p} + \bar{q} = \bar{t}$ . Write  $\bar{p} \leq \bar{q}$  if  $p_k \leq q_k$  for all  $k$ . Let  $g$  be an adapted metric on  $M$  of type  $\hat{u} = (u_2, \dots, u_n)$ . If  $\hat{u}$  is associated with a perversity  $\bar{p} \leq \bar{m}$  in the sense

$$\left. \begin{aligned} \frac{1}{k-1-2p_k} \leq u_k < \frac{1}{k-3-2p_k} & \quad \text{if } 2p_k \leq k - 3, \\ 1 \leq u_k < \infty & \quad \text{if } 2p_k = k - 2, \end{aligned} \right\} \quad (1.7.1)$$

then (see [13, 53, 54])

$$I^{\bar{p}}H_r(A)^* \cong H_{(2)}^r(M) \cong H_{\max}^r(M),$$

and therefore  $\beta_r^{\bar{p}} = \beta_{\max}^r$ . In particular,  $H_{(2)}^r(M) \cong I^{\bar{m}}H_r(A)^*$  if  $g$  is an adapted metric of conic type [20]. Thus the incompatibility of adapted metrics with products is related to the subtleties of the versions of the Künneth theorem for intersection homology [22, 29]. For instance, for arbitrary pseudomanifolds  $P$  and  $Q$ , the isomorphism  $I^{\bar{p}}H_*(P \times Q) \cong I^{\bar{p}}H_*(P) \otimes I^{\bar{p}}H_*(Q)$  only holds with some special perversities  $\bar{p}$ , including  $\bar{p} = \bar{m}$ . According to (1.7.1), there exist good adapted metrics on  $M$  whose type is associated with any given perversity  $\leq \bar{m}$ .

In (1.7.1), only the choices  $2p_k = k - 2, k - 4, \dots$  are possible if  $k$  is even, and only the choices  $2p_k = k - 3, k - 5, \dots$  are possible if  $k$  is odd. Thus, for every  $k$ , (1.7.1) establishes a bijection between the possibilities for  $p_k$  and the elements of a partition of  $[\frac{1}{k-1}, \infty)$  into semi-open intervals, where  $u_k$  is taken.

Let  $f$  be a rel-Morse function on  $M$ , let  $x \in \text{Crit}_{\text{rel}}(f)$ , let  $X$  be the stratum of  $\widehat{M}$  containing  $x$ , and let  $k = \text{codim } X$ . With the above notation for a chart  $O \equiv O'$  of  $\widehat{M}$  centered at  $x$ , there is an adapted metric  $\tilde{g}$  on  $N$  so that, via the chart,  $g|_O$  is quasi-isometric to the restriction of  $g_0 + \rho_X^{2u_k} \tilde{g} + (d\rho_X)^2$  to  $M' \cap O'$ . Then the type of  $\tilde{g}$  is also associated with  $\bar{p}$ . Moreover there is some expression,  $m_X = m_+ + m_-$  ( $m_{\pm} \in \mathbb{N}$ ), and some decomposition,  $c(L_X) \equiv c(L_+) \times c(L_-)$ , so that  $M' \equiv \mathbb{R}^{m_+} \times N_+ \times \mathbb{R}_+ \times \mathbb{R}^{m_-} \times N_- \times \mathbb{R}_+$  for dense strata  $N_{\pm}$  of  $L_{\pm}$ , and  $f|_O \equiv f(x) + \frac{1}{2}(\rho_+^2 - \rho_-^2)|_O$ , where  $\rho_{\pm}$  is the radial function of  $\mathbb{R}^{m_{\pm}} \times c(L_{\pm})$ . Let  $k_{\pm} = \dim N_{\pm} + 1$ ; thus  $k = k_+ + k_-$ . Here, some of the stratifications  $L_{\pm}$  may be empty; in fact,  $L_+ \neq \emptyset \neq L_-$  only can happen if  $u_k = 1$  (Section 1.3). From (1.4.1) and (1.4.2), it follows that the numbers  $\nu_{x, \max}^r$  are independent of the choice of  $\hat{u}$  associated with  $\bar{p}$ , and therefore the notation  $\nu_{x,r}^{\bar{p}} = \nu_{x,r}^{\bar{p}}(f)$  will be used. Precisely, they have the following expressions:

- If  $L_+ \neq \emptyset \neq L_-$  (only if  $u_k = 1$ ), then

$$\nu_{x,r}^{\bar{p}} = \sum_{(r_+, r_-)} \beta_{r_+}^{\bar{p}}(L_+) \beta_{r_-}^{\bar{p}}(L_-),$$

where  $(r_+, r_-)$  runs in the subset of  $\mathbb{N}^2$  determined by the conditions

$$r = m_- + r_+ + r_- + 1, \quad r_+ < \frac{k_+}{2}, \quad r_- \geq \frac{k_-}{2}.$$

- If  $L_X = L_+ \neq \emptyset$  ( $L_- = \emptyset$ ), then

$$\nu_{x,r}^{\bar{p}} = \sum_{r_+} \beta_{r_+}^{\bar{p}}(L_X),$$

where  $r_+$  runs in the subset of  $\mathbb{N}$  determined by the conditions

$$r = m_- + r_+, \quad r_+ < \begin{cases} k - 1 - p_k & \text{if } u_k < 1 \\ \frac{k}{2} & \text{if } u_k = 1. \end{cases}$$

- If  $L_X = L_- \neq \emptyset$  ( $L_+ = \emptyset$ ), then

$$\nu_{x,r}^{\bar{p}} = \sum_{r_-} \beta_{r_-}^{\bar{p}}(L_X),$$

where  $r_-$  runs in the subset of  $\mathbb{N}$  determined by the conditions

$$r = m_- + r_- + 1, \quad r_- \geq \begin{cases} k - 1 - p_k & \text{if } u_k < 1 \\ \frac{k}{2} & \text{if } u_k = 1. \end{cases}$$

- If  $L_X = \emptyset$ , then  $\nu_{x,r}^{\bar{p}} = \delta_{r,m_-}$ .

Finally, let  $\nu_r^{\bar{p}} = \nu_r^{\bar{p}}(f) = \sum_x \nu_{x,r}^{\bar{p}}$  ( $x \in \text{Crit}_{\text{rel}}(f)$ ), which equals  $\nu_{\text{max}}^r$ .

Suppose now that  $A$  is oriented ( $M$  is oriented) and compact. We have  $\beta_{\text{min}}^r = \beta_{\text{max}}^{n-r}$  for all  $r$  because  $\Delta_{\text{min}}$  corresponds to  $\Delta_{\text{max}}$  by the Hodge star operator. On the other hand, for any perversity  $\bar{q} \geq \bar{n}$ , if  $\bar{p} \leq \bar{m}$  is complementary of  $\bar{q}$ , then  $I^{\bar{q}}H_r(A) \cong I^{\bar{p}}H_{n-r}(A)^*$  [32, 33], and therefore  $\beta_r^{\bar{q}} = \beta_{n-r}^{\bar{p}}$ , obtaining  $\beta_r^{\bar{q}} = \beta_{\text{min}}^r$ . As before, it follows from (1.4.1) and (1.4.2) that the numbers  $\nu_{x,\text{min}}^r$  are independent of the choice of  $\hat{u}$  associated with  $\bar{p}$ . Precisely, with the notation  $\nu_{x,r}^{\bar{q}} = \nu_{x,r}^{\bar{q}}(f) = \nu_{x,\text{min}}^r$ , they have the following expressions:

- If  $L_+ \neq \emptyset \neq L_-$  (only if  $u_k = 1$ ), then

$$\nu_{x,r}^{\bar{q}} = \sum_{(r_+, r_-)} \beta_{r_+}^{\bar{q}}(L_+) \beta_{r_-}^{\bar{q}}(L_-),$$

where  $(r_+, r_-)$  runs in the subset of  $\mathbb{N}^2$  determined by the conditions

$$r = m_- + r_+ + r_- + 1, \quad r_+ \leq \frac{k_+}{2} - 1, \quad r_- > \frac{k_-}{2} - 1.$$

- If  $L_X = L_+ \neq \emptyset$  ( $L_- = \emptyset$ ), then

$$\nu_{x,r}^{\bar{q}} = \sum_{r_+} \beta_{r_+}^{\bar{q}}(L_X),$$

where  $r_+$  runs in the subset of  $\mathbb{N}$  determined by the conditions

$$r = m_- + r_+, \quad r_+ \leq \begin{cases} k - 2 - q_k & \text{if } u_k < 1 \\ \frac{k}{2} - 1 & \text{if } u_k = 1. \end{cases}$$

- If  $L_X = L_- \neq \emptyset$  ( $L_+ = \emptyset$ ), then

$$\nu_{x,r}^{\bar{q}} = \sum_{r_-} \beta_{r_-}^{\bar{q}}(L_X),$$

where  $r_-$  runs in the subset of  $\mathbb{N}$  determined by the conditions

$$r = m_- + r_- + 1, \quad r_- > \begin{cases} k - 2 - q_k & \text{if } u_k < 1 \\ \frac{k}{2} - 1 & \text{if } u_k = 1. \end{cases}$$

- If  $L_X = \emptyset$ , then  $\nu_{x,r}^{\bar{q}} = \delta_{r,m_-}$ .

Like  $\nu_r^{\bar{p}}$ , we also define  $\nu_r^{\bar{q}} = \nu_r^{\bar{q}}(f) = \sum_x \nu_{x,r}^{\bar{q}}$  ( $x \in \text{Crit}_{\text{rel}}(f)$ ), which equals  $\nu_{\min}^r$ .

Theorem 1.6.2 has the following direct consequence.

**Corollary 1.7.1.** *Let  $A$  be a compact pseudomanifold of dimension  $n$ , let  $M$  be its regular stratum, and let  $\bar{p}$  be a perversity. If  $\bar{p} \leq \bar{m}$ , or if  $A$  is oriented and  $\bar{p} \geq \bar{n}$ , then, for any rel-Morse function on  $M$  (with respect to any good adapted metric), we have*

$$\sum_{r=0}^k (-1)^{k-r} \beta_r^{\bar{p}} \leq \sum_{r=0}^k (-1)^{k-r} \nu_r^{\bar{p}} \quad (0 \leq k < n),$$

$$\chi^{\bar{p}} = \sum_{r=0}^n (-1)^r \nu_r^{\bar{p}}.$$

Stratified Morse theory was introduced by Goresky and MacPherson [35], and has a great wealth of applications. In particular, Goresky and MacPherson have proved Morse inequalities on complex analytic varieties with Whitney stratifications, involving the intersection homology with perversity  $\bar{m}$  [35, Chapter 6, Section 6.12]. Ludwig also gave an analytic interpretation of Morse theory in the spirit of Goresky and MacPherson for conformally conic manifolds [44–47]. In this thesis, the version of Morse functions, critical points and associated numbers is different from those used in [35], even in the case of perversity  $\bar{m}$ . To the author's knowledge, Corollary 1.7.1 is the first version of Morse inequalities given for intersection homology with perversity  $\neq \bar{m}$ .

Consider now the notation of Section 1.5. The *intersection Lefschetz number* of a morphism  $\psi$ , with respect to the perversity  $\bar{p}$ , is defined [34] as

$$I^{\bar{p}}L(\psi) = \sum_{r=0}^n (-1)^r \text{tr}(\psi^* \text{ on } I^{\bar{p}}H_r(A)^*).$$

Theorem 1.6.3 has the following direct consequence.

**Corollary 1.7.2.** *Let  $A$  be a compact orientable pseudomanifold of dimension  $n$  with isolated singularities and regular stratum  $M$ . Let  $\bar{p}$  be a perversity. If  $\bar{p} \leq \bar{m}$  or  $\bar{p} \geq \bar{n}$ , then, for any morphism  $\psi : A \rightarrow A$  satisfying hypotheses (a)–(c), we have*

$$I^{\bar{p}}L(\psi) = \sum_{q \in \text{Fix}(\psi) \cap M} \text{sign det}(1 - T_q\psi) + \sum_{q \in \text{sing}(A)} L(G_q).$$

## 1.8 Ideas of the proofs

In the proofs of Theorems 1.6.1 and 1.6.2, several steps are like in the case of adapted metrics of conic type [5]. Only brief indications of those steps are given in this thesis, whereas the parts with new ideas are explained with detail. We adapt the well-known analytic method of Witten [70]; specially, as described in [59, Chapters 9 and 14]. Thus, given a rel-Morse function  $f$  on  $M$ , we consider the Witten's perturbation  $d_s = e^{-sf} de^{sf} = d + s df \wedge$  on  $\Omega_0(M)$  ( $s > 0$ ). Let  $d_{s,\text{max/min}}$  denote its maximum/minimum i.b.c., with corresponding Laplacian  $\Delta_{s,\text{max/min}}$ . Since  $\Delta_{s,\text{max/min}} - \Delta_{\text{max/min}}$  is bounded, it is enough to prove the properties of Theorem 1.6.1 for  $\Delta_{s,\text{max/min}}$ . Moreover, using the globalization procedure given by Propositions A.2.1 and A.2.2, and a version of the Künneth theorem [15, Corollary 2.15], [5, Lemma 5.1], it is enough to consider the case of a stratum  $M = N \times \mathbb{R}_+$  of a cone  $c(L)$  (a non-compact stratification), with a good general adapted metric of the form  $g = \rho^{2u} \tilde{g} + d\rho^2$ , and the rel-Morse function  $\pm \frac{1}{2} \rho^2$ , where  $\rho$  is the radial function and  $L$  a compact stratification of smaller depth. A tilde is added to the notation of concepts considered for  $N$ . By induction on the depth, it is assumed that  $\tilde{\Delta}_{\text{max/min}}$  satisfies the properties of Theorem 1.6.1. Then its eigenforms are used like in [5] to split  $d_{s,\text{max/min}}$  into a direct sum of Hilbert complexes of length one and two, which can be described as the maximum/minimum i.b.c. of certain elliptic complexes on  $\mathbb{R}_+$ . The elliptic complexes of length one are of the same kind as in [5], so that the Laplacian of their maximum/minimum i.b.c. is induced by the Dunkl harmonic oscillator on  $\mathbb{R}$  [4], whose spectrum is well known. However, the Laplacian of the elliptic complexes of length two is a perturbation of the Dunkl harmonic oscillator containing new terms of the form  $\rho^{-2u}$  and  $\rho^{-2u-1}$ . A different analytic tool is used here, which is developed in Chapter 4. Precisely, classical perturbation methods are used in Chapter 4 to determine self-adjoint operators with discrete spectra defined by this perturbation of the Dunkl harmonic oscillator, giving also upper and lower estimates of its eigenvalues. The application of this analytic tool is what requires  $g$  to be good. The information obtained for this perturbation is weaker than for the Dunkl harmonic oscillator. For instance, such self-adjoint operators are only known to exist in some cases, and only a core of their square root is known. Thus more work is needed here than in [5] to describe the Laplacians of the maximum/minimum i.b.c.

of the simple elliptic complexes of length two, using those self-adjoint operators. The proof of Theorem 1.6.1 can be completed with such information like in [5]. On the other hand, only eigenvalue estimates of those self-adjoint operators are known, which makes it more difficult to determine the “cohomological contribution” of the rel-critical points. This is the key idea to complete the proof of Theorem 1.6.2 like in [5]. The proof of Theorem 1.6.3 is based on the classical Lefschetz trace formula for smooth maps on compact manifolds [59, Theorem 10.12]. This gives the null contribution of the non-fixed points and a formula for the contribution of the regular fixed points. So the novelty of the proof is the use of the harmonic eigenforms obtained from the splitting of  $d_{s,\max/\min}$  in order to compute the singular (fixed) points contribution.

## 1.9 Some open problems

We do not know whether the condition on  $g$  to be good could be deleted. It depends on whether the results used from Chapter 4 hold with weaker hypotheses.

The applications would increase by extending the present version of Morse inequalities to “rel-Morse-Bott functions.” Their rel-critical point sets would be finite unions of substratifications. Also the Lefschetz trace formula could be extended to the context of general stratifications, but this would involve certain control result for the heat kernel outside the diagonal.

There should be an extension of the isomorphism  $H_{(2)}^r(M) \cong I^{\bar{p}}H_r(A)^*$  to the case of general adapted metrics and general perversities [30]. In that direction, an extension of the de Rham theorem with general perversities was proved in [63, 64]. The case with classical perversities was previously considered in [12, 17].

It is also natural to continue with the following program, already achieved on closed manifolds. First, it should be shown that there is a spectral gap of the form  $\sigma(\Delta_{s,\max/\min}) \cap (C_1e^{-C_2s}, C_3s) = \emptyset$ , for some  $C_1, C_2, C_3 > 0$ . This would define a finite-dimensional complex  $(\mathcal{S}_{s,\max/\min}, d_s)$  generated by the eigenforms corresponding to eigenvalues in  $[0, C_1e^{-C_2s}]$  (“small eigenvalues”). Second, it should be proved that  $(\mathcal{S}_{s,\max/\min}, d_s)$  “converges” to the “rel-Morse-Thom-Smale complex,” assuming that the function satisfies the “rel-Morse-Smale transversality condition.” It seems that the existence of the above spectral gap would follow easily by adapting the arguments of Propositions A.2.1 and A.2.2. The comparison of  $(\mathcal{S}_{s,\max/\min}, d_s)$  with the “rel-Morse-Thom-Smale complex” would require additional techniques, according to the case of closed manifolds [36], [11, Section 6]. This program was developed by Ludwig in a special case [48].

## 1.10 Dunkl Harmonic Oscillator

Let us explain the analytic tools that were developed to prove the main theorems of this thesis (Section 1.6). The results stated in this section were published in [6].

The Dunkl operator on  $\mathbb{R}^n$  was introduced by Dunkl [24–26], and gave rise to what is now called the Dunkl theory [62]. It plays an important role in Physics and stochastic processes (see e.g. [31,61,68]). In particular, the Dunkl harmonic oscillator on  $\mathbb{R}^n$  was studied in [27,55,56,60]. We will consider only this operator on  $\mathbb{R}$ , where it is uniquely determined by one parameter. In this case, a conjugation of the Dunkl operator was previously introduced by Yang [71] (see also [57]).

Let us fix some notation that is used in this section and in the whole Chapter 4. Let  $\mathcal{S} = \mathcal{S}(\mathbb{R})$  be the Schwartz space on  $\mathbb{R}$ , with its Fréchet topology. It decomposes as direct sum of subspaces of even and odd functions,  $\mathcal{S} = \mathcal{S}_{\text{ev}} \oplus \mathcal{S}_{\text{odd}}$ . The even/odd component of a function in  $\mathcal{S}$  is denoted with the subindex *ev/odd*. Since  $\mathcal{S}_{\text{odd}} = x\mathcal{S}_{\text{ev}}$ , where  $x$  is the standard coordinate of  $\mathbb{R}$ ,  $x^{-1}\phi \in \mathcal{S}_{\text{ev}}$  is defined for  $\phi \in \mathcal{S}_{\text{odd}}$ . Let  $L_\sigma^2 = L^2(\mathbb{R}, |x|^{2\sigma} dx)$  ( $\sigma \in \mathbb{R}$ ), whose scalar product and norm are denoted by  $\langle \cdot, \cdot \rangle_\sigma$  and  $\| \cdot \|_\sigma$ . The above decomposition of  $\mathcal{S}$  extends to an orthogonal decomposition,  $L_\sigma^2 = L_{\sigma,\text{ev}}^2 \oplus L_{\sigma,\text{odd}}^2$ , because the function  $|x|^{2\sigma}$  is even.  $\mathcal{S}$  is a dense subspace of  $L_\sigma^2$  if  $\sigma > -\frac{1}{2}$ , and  $\mathcal{S}_{\text{odd}}$  is a dense subspace of  $L_{\tau,\text{odd}}^2$  if  $\tau > -\frac{3}{2}$ . Unless otherwise stated, we assume  $\sigma > -\frac{1}{2}$  and  $\tau > -\frac{3}{2}$ . The domain of a (densely defined) operator  $P$  in a Hilbert space is denoted by  $D(P)$ . If  $P$  is closable, its closure is denoted by  $\overline{P}$ . The domain of a (densely defined) sesquilinear form  $\mathfrak{p}$  in a Hilbert space is denoted by  $D(\mathfrak{p})$ . The quadratic form of  $\mathfrak{p}$  is also denoted by  $\mathfrak{p}$ . If  $\mathfrak{p}$  is closable, its closure is denoted by  $\overline{\mathfrak{p}}$ . For an operator in  $L_\sigma^2$  preserving the above decomposition, its restrictions to  $L_{\sigma,\text{ev/odd}}^2$  will be indicated with the subindex *ev/odd*. The operator of multiplication by a continuous function  $h$  in  $L_\sigma^2$  is also denoted by  $h$ . The harmonic oscillator is the operator  $H = -\frac{d^2}{dx^2} + s^2x^2$  ( $s > 0$ ) in  $L_0^2$  with  $D(H) = \mathcal{S}$ .

The Dunkl operator on  $\mathbb{R}$  is the operator  $T$  in  $L_\sigma^2$ , with  $D(T) = \mathcal{S}$ , determined by  $T = \frac{d}{dx}$  on  $\mathcal{S}_{\text{ev}}$  and  $T = \frac{d}{dx} + 2\sigma x^{-1}$  on  $\mathcal{S}_{\text{odd}}$ , and the Dunkl harmonic oscillator on  $\mathbb{R}$  is the operator  $J = -T^2 + s^2x^2$  in  $L_\sigma^2$  with  $D(J) = \mathcal{S}$ . Thus  $J$  preserves the above decomposition of  $\mathcal{S}$ , being  $J_{\text{ev}} = H - 2\sigma x^{-1} \frac{d}{dx}$  and  $J_{\text{odd}} = H - 2\sigma \frac{d}{dx} x^{-1}$ . The subindex  $\sigma$  is added to  $J$  if needed. This  $J$  is essentially self-adjoint, and the spectrum of  $\overline{J}$  is well known [60]; in particular,  $\overline{J} > 0$ . In fact, even for  $\tau > -\frac{3}{2}$ , the operator  $J_{\tau,\text{odd}}$  is defined in  $L_{\tau,\text{odd}}^2$  with  $D(J_{\tau,\text{odd}}) = \mathcal{S}_{\text{odd}}$  because it is a conjugation of  $J_{\tau+1,\text{ev}}$  by a unitary operator (Section 4.1). Some operators of the form  $J + \xi x^{-2}$  ( $\xi \in \mathbb{R}$ ) are conjugates of  $J$  by powers  $|x|^a$  ( $a \in \mathbb{R}$ ), and therefore their study can be reduced to the case of  $J$  [4]. The following theorem analyzes a different perturbation of  $J$ .

**Theorem 1.10.1.** *Let  $0 < u < 1$  and  $\xi > 0$ . If  $\sigma > u - \frac{1}{2}$ , then there is a positive self-adjoint operator  $\mathcal{U}$  in  $L^2_\sigma$  satisfying the following:*

(i)  $\mathcal{S}$  is a core of  $\mathcal{U}^{1/2}$ , and, for all  $\phi, \psi \in \mathcal{S}$ ,

$$\langle \mathcal{U}^{1/2}\phi, \mathcal{U}^{1/2}\psi \rangle_\sigma = \langle J\phi, \psi \rangle_\sigma + \xi \langle |x|^{-u}\phi, |x|^{-u}\psi \rangle_\sigma. \quad (1.10.1)$$

(ii)  $\mathcal{U}$  has a discrete spectrum. Let  $\lambda_0 \leq \lambda_1 \leq \dots$  be its eigenvalues, repeated according to their multiplicity. There is some  $D = D(\sigma, u) > 0$  and, for any  $\epsilon > 0$ , there is some  $C = C(\epsilon, \sigma, u) > 0$  so that, for all  $k \in \mathbb{N}$ ,

$$\lambda_k \geq (2k + 1 + 2\sigma)s + \xi D s^u (k + 1)^{-u}, \quad (1.10.2)$$

$$\lambda_k \leq (2k + 1 + 2\sigma)(s + \xi \epsilon s^u) + \xi C s^u. \quad (1.10.3)$$

*Remark 1.10.2.* In Theorem 1.10.1, observe the following:

- (i) The second term of the right hand side of (1.10.1) makes sense because  $|x|^{-u}\mathcal{S} \subset L^2_\sigma$  since  $\sigma > u - \frac{1}{2}$ .
- (ii)  $\mathcal{U} = \overline{U}$ , where  $U = J + \xi|x|^{-2u}$  with  $D(U) = \bigcap_{m=0}^\infty D(\mathcal{U}^m)$  (see [41, VI-§ 2.5]). The more explicit notation  $U_\sigma$  will be also used if necessary.
- (iii) The restrictions  $\mathcal{U}_{\text{ev/odd}}$  are self-adjoint in  $L^2_{\sigma, \text{ev/odd}}$  and satisfy (1.10.1) with  $\phi, \psi \in \mathcal{S}_{\text{ev/odd}}$ . They also satisfy (1.10.2) and (1.10.3) with  $k$  even/odd. In fact, by the comments before the statement,  $\mathcal{U}_{\tau, \text{odd}}$  is defined and verifies these properties if  $\tau > u - \frac{3}{2}$ .

To prove Theorem 1.10.1, we consider the positive definite symmetric sesquilinear form  $u$  defined by the right hand side of (1.10.1). Perturbation theory [41] is used to show that  $u$  is closable and  $\bar{u}$  induces a self-adjoint operator  $\mathcal{U}$ , and to relate the spectra of  $\mathcal{U}$  and  $\overline{J}$ . Most of the work is devoted to check the conditions to apply this theory so that (1.10.2) and (1.10.3) follow; indeed, (1.10.2) and (1.10.3) are stronger than a general eigenvalue estimate given by that theory (Remark 4.2.22).

The following generalizations of Theorem 1.10.1 follow with a simple adaptation of the proof. If  $\xi < 0$ , we only have to reverse the inequalities (1.10.2) and (1.10.3). In (1.10.1), we may use a finite sum  $\sum_i \xi_i \langle |x|^{-u_i}\phi, |x|^{-u_i}\psi \rangle_\sigma$ , where  $0 < u_i < 1$ ,  $\sigma > u_i - \frac{1}{2}$  and  $\xi_i > 0$ ; then (1.10.2) and (1.10.3) would be modified by using  $\max_i u_i$  and  $\min_i \xi_i$  in the left hand side, and  $\max_i \xi_i$  in the right hand side. In turn, this can be extended by taking  $\mathbb{R}^p$ -valued functions ( $p \in \mathbb{Z}_+$ ), and a finite sum  $\sum_i \langle |x|^{-u_i} \Xi_i \phi, |x|^{-u_i} \psi \rangle_\sigma$  in (1.10.1), where each  $\Xi_i$  is a positive definite self-adjoint endomorphism of  $\mathbb{R}^p$ ; then the minimum and maximum eigenvalues of all  $\Xi_i$  would be used in (1.10.2) and (1.10.3).

As an open problem, we may ask for a version of Theorem 1.10.1 using Dunkl operators on  $\mathbb{R}^n$ , but we are interested in the following different type of extension. For  $\sigma > -\frac{1}{2}$  and  $\tau > -\frac{3}{2}$ , let  $L_{\sigma,\tau}^2 = L_{\sigma,\text{ev}}^2 \oplus L_{\tau,\text{odd}}^2$ , whose scalar product and norm are denoted by  $\langle \cdot, \cdot \rangle_{\sigma,\tau}$  and  $\| \cdot \|_{\sigma,\tau}$ . Matrix expressions of operators refer to this decomposition. Let  $J_{\sigma,\tau} = J_{\sigma,\text{ev}} \oplus J_{\tau,\text{odd}}$  in  $L_{\sigma,\tau}^2$ , with  $D(J_{\sigma,\tau}) = \mathcal{S}$ . The hypotheses of the following generalization of Theorem 1.10.1 are rather involved to cover enough cases of the application presented in Section 2.2.

**Theorem 1.10.3.** *Let  $\xi > 0$  and  $\eta \in \mathbb{R}$ , let*

$$0 < u < 1, \quad \sigma > u - \frac{1}{2}, \quad \tau > u - \frac{3}{2}, \quad \theta > -\frac{1}{2}, \quad (1.10.4)$$

and set  $v = \sigma + \tau - 2\theta$ . Suppose that the following conditions hold:

(a) *If  $\sigma = \theta \neq \tau$  and  $\tau - \sigma \notin -\mathbb{N}$ , then*

$$\sigma - 1 < \tau < \sigma + 1, 2\sigma + \frac{1}{2}. \quad (1.10.5)$$

(b) *If  $\sigma \neq \theta = \tau$  and  $\sigma - \tau \notin -\mathbb{N}$ , then*

$$-\tau, \tau - 1 < \sigma < 3\tau + 1, 11\tau + 2, \tau + 1. \quad (1.10.6)$$

(c) *If  $\sigma \neq \theta = \tau + 1$  and  $\sigma - \tau - 1 \notin -\mathbb{N}$ , then*

$$\tau + 1 < \sigma < \tau + 3, 2\tau + \frac{7}{2}. \quad (1.10.7)$$

(d) *If  $\sigma \neq \theta \neq \tau$  and  $\sigma - \theta, \tau - \theta \notin -\mathbb{N}$ , then*

$$\left. \begin{aligned} \frac{\sigma-\tau}{2} - 1, \frac{\tau-\sigma}{2}, \frac{\sigma+\tau-1}{4}, \frac{\sigma+3\tau-2}{14}, \frac{3\sigma+\tau-4}{14}, \frac{\sigma+\tau-1}{2} < \theta < \frac{\sigma+\tau+1}{2}, \\ \tau - 1 < \sigma < \tau + 3. \end{aligned} \right\} \quad (1.10.8)$$

Then there is a positive self-adjoint operator  $\mathcal{V}$  in  $L_{\sigma,\tau}^2$  satisfying the following:

(i)  $\mathcal{S}$  is a core of  $\mathcal{V}^{1/2}$ , and, for all  $\phi, \psi \in \mathcal{S}$ ,

$$\begin{aligned} \langle \mathcal{V}^{1/2}\phi, \mathcal{V}^{1/2}\psi \rangle_{\sigma,\tau} &= \langle J_{\sigma,\tau}\phi, \psi \rangle_{\sigma,\tau} + \xi \langle |x|^{-u}\phi, |x|^{-u}\psi \rangle_{\sigma,\tau} \\ &\quad + \eta (\langle x^{-1}\phi_{\text{odd}}, \psi_{\text{ev}} \rangle_{\theta} + \langle \phi_{\text{ev}}, x^{-1}\psi_{\text{odd}} \rangle_{\theta}). \end{aligned} \quad (1.10.9)$$

(ii) Let  $\varsigma_k = \sigma$  if  $k$  is even, and  $\varsigma_k = \tau$  if  $k$  is odd.  $\mathcal{V}$  has a discrete spectrum. Its eigenvalues form two groups,  $\lambda_0 \leq \lambda_2 \leq \dots$  and  $\lambda_1 \leq \lambda_3 \leq \dots$ , repeated according to their multiplicity, such that there is some  $D = D(\sigma, \tau, u) > 0$  and,

for every  $\epsilon > 0$ , there are  $C = C(\epsilon, \sigma, \tau, u) > 0$  and  $E = E(\epsilon, \sigma, \tau, \theta) > 0$  so that, for all  $k \in \mathbb{N}$ ,

$$\begin{aligned} \lambda_k &\geq (2k + 1 + 2\varsigma_k) \left( s - 2|\eta| \epsilon s^{\frac{v+1}{2}} \right) \\ &\quad + \xi D s^u (k + 1)^{-u} - 2|\eta| E s^{\frac{v+1}{2}}, \end{aligned} \quad (1.10.10)$$

$$\begin{aligned} \lambda_k &\leq (2k + 1 + 2\varsigma_k) \left( s + \epsilon (\xi s^u + 2|\eta| s^{\frac{v+1}{2}}) \right) \\ &\quad + \xi C s^u + 2|\eta| E s^{\frac{v+1}{2}}. \end{aligned} \quad (1.10.11)$$

(iii) Let  $\tilde{u} \in \mathbb{R}$  such that

$$0, v, \tau - 2\theta + \frac{1}{2}, \sigma - 2\theta - \frac{1}{2} < \tilde{u} < 1, v + 1, \sigma + \frac{1}{2}, \tau + \frac{3}{2}, \quad (1.10.12)$$

and let  $\hat{u} = \max\{\tilde{u}, v + 1 - \tilde{u}\}$ . There is some  $D = D(\sigma, \tau, u) > 0$  and, for any  $\epsilon > 0$ , there is some  $\tilde{C} = \tilde{C}(\epsilon, \sigma, \tau, u) > 0$  so that, for all  $k \in \mathbb{N}$ ,

$$\lambda_k \geq (2k + 1 + 2\varsigma_k) \left( s - |\eta| \epsilon s^{\hat{u}} \right) + \xi D s^u (k + 1)^{-u} - |\eta| \tilde{C} s^{\hat{u}}. \quad (1.10.13)$$

(iv) If  $u = \frac{v+1}{2}$  and  $\xi \geq |\eta|$ , then there is some  $\tilde{D} = \tilde{D}(\sigma, \tau, u) > 0$  so that, for all  $k \in \mathbb{N}$ ,

$$\lambda_k \geq (2k + 1 + 2\varsigma_k) s + (\xi - |\eta|) \tilde{D} s^u (k + 1)^{-u}. \quad (1.10.14)$$

(v) If we add the term  $\xi' \langle \phi_{\text{ev}}, \psi_{\text{ev}} \rangle_{\sigma} + \xi'' \langle \phi_{\text{odd}}, \psi_{\text{odd}} \rangle_{\tau}$  to the right hand side of (1.10.9), for some  $\xi', \xi'' \in \mathbb{R}$ , then the result holds as well with the additional term  $\max\{\xi', \xi''\}$  in the right hand side of (1.10.11), and the additional term,  $\xi'$  for  $k \in 2\mathbb{N}$  and  $\xi''$  for  $k \in 2\mathbb{N} + 1$ , in the right hand sides of (1.10.10), (1.10.13) and (1.10.14).

**Remark 1.10.4.** In Theorem 1.10.3, observe the following:

(i) Like in Remark 1.10.2-(ii), we have  $\mathcal{V} = \overline{\mathcal{V}}$ , where

$$V = \begin{pmatrix} U_{\sigma, \text{ev}} & \eta |x|^{2(\theta-\sigma)} x^{-1} \\ \eta |x|^{2(\theta-\tau)} x^{-1} & U_{\tau, \text{odd}} \end{pmatrix},$$

with  $D(V) = \bigcap_{m=0}^{\infty} D(\mathcal{V}^m)$ . Note that the adjoint operator of  $|x|^{2(\theta-\sigma)} x^{-1} : \mathcal{S}_{\text{odd}} \rightarrow |x|^{2(\theta-\sigma)} \mathcal{S}_{\text{ev}}$ , as a densely defined operator of  $L_{\tau, \text{odd}}^2$  to  $L_{\sigma, \text{ev}}^2$ , is given by  $|x|^{2(\theta-\tau)} x^{-1}$ , with the appropriate domain.

(ii) Taking  $\theta' = \theta - 1 > -\frac{3}{2}$ , since

$$\langle x\phi, \psi \rangle_{\theta'} = \langle \phi, x^{-1}\psi \rangle_{\theta}$$

for all  $\phi \in \mathcal{S}_{\text{ev}}$  and  $\psi \in \mathcal{S}_{\text{odd}}$ , we can write (1.10.9) as

$$\begin{aligned} \langle \mathcal{V}^{1/2}\phi, \mathcal{V}^{1/2}\psi \rangle_{\sigma, \tau} &= \langle J_{\sigma, \tau}\phi, \psi \rangle_{\sigma, \tau} + \xi \langle |x|^{-u}\phi, |x|^{-u}\psi \rangle_{\sigma, \tau} \\ &\quad + \eta (\langle \phi_{\text{odd}}, x\psi_{\text{ev}} \rangle_{\theta'} + \langle x\phi_{\text{ev}}, \psi_{\text{odd}} \rangle_{\theta'}), \end{aligned}$$

for all  $\phi, \psi \in \mathcal{S}$ , and, correspondingly,

$$V = \begin{pmatrix} U_{\sigma, \text{ev}} & \eta|x|^{2(\theta' - \sigma)}x \\ \eta|x|^{2(\theta' - \tau)}x & U_{\tau, \text{odd}} \end{pmatrix}.$$

(iii) The conditions (1.10.5), (1.10.6) and (1.10.7) describe three convex open subsets of  $\mathbb{R}^2$  (Figure 1.10.1). The condition (1.10.8) describes a convex open subset of  $\mathbb{R}^3$  (Figure 1.10.2), which is symmetric with respect to the plane defined by  $\sigma = \tau + 1$ . It is a “semi-infinite bar” with 4 lateral faces, and 5 faces at the “bounded end.”

(iv) In Theorem 1.10.3-(iii), the condition (1.10.12) means that (1.10.4) also holds with  $\tilde{u}$  and  $v + 1 - \tilde{u}$  instead of  $u$ . There exists  $\tilde{u}$  satisfying (1.10.12) just when

$$0, v, \tau - 2\theta + \frac{1}{2}, \sigma - 2\theta - \frac{1}{2} < 1, v + 1, \sigma + \frac{1}{2}, \tau + \frac{3}{2}. \quad (1.10.15)$$

This property holds in the cases (b) and (d) by (1.10.4), (1.10.6) and (1.10.8); in particular, we can take  $\tilde{u} = \frac{v+1}{2}$ . In the case (a), if  $\tau < 3\sigma$ , then (1.10.15) holds by (1.10.4) and (1.10.5). In the case (c), if  $\sigma < 3\tau + 4$ , then (1.10.15) holds by (1.10.4) and (1.10.7).

The main arguments of the proofs are given in Sections 4.2–4.4. But some needed estimates are postponed to Sections 4.5 and 4.6 because they are of rather independent nature, and with rather long and tedious proofs.

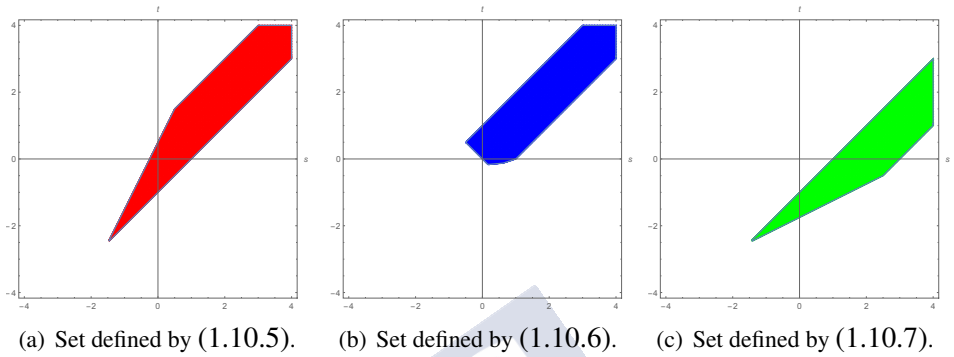

Figure 1.10.1: Sets in Theorem 1.10.3-(a),(b),(c).

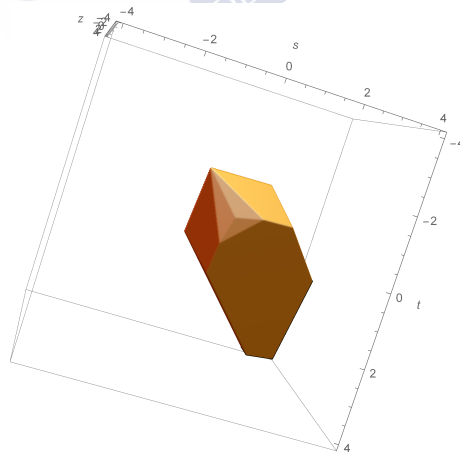
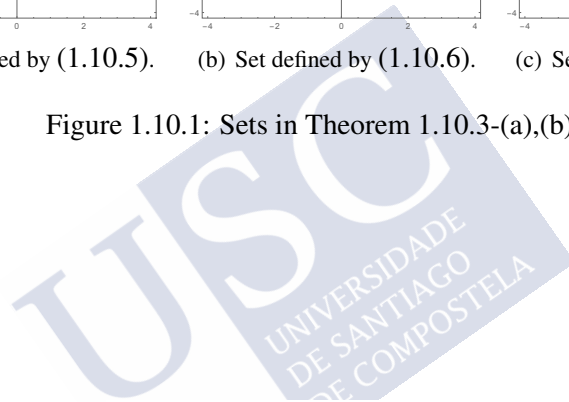

Figure 1.10.2: Set defined by (1.10.8) in Theorem 1.10.3-(d).



# Witten's Perturbation on Strata

---

## Contents

|            |  |           |
|------------|--|-----------|
| <b>2.1</b> | <b>Preliminaries</b> . . . . .                                       | <b>25</b> |
| 2.1.1      | Products of cones . . . . .  | 25        |
| 2.1.2      | General adapted metrics . . . . .                                    | 27        |
| 2.1.3      | Relatively Morse functions . . . . .                                 | 28        |
| 2.1.4      | Hilbert and elliptic complexes . . . . .                             | 29        |
| <b>2.2</b> | <b>Two simple types of elliptic complexes</b> . . . . .              | <b>31</b> |
| 2.2.1      | An elliptic complex of length one . . . . .                          | 31        |
| 2.2.2      | An elliptic complex of length two . . . . .                          | 34        |
| 2.2.3      | The wave operator . . . . .  | 46        |
| <b>2.3</b> | <b>Witten's perturbation on a cone</b> . . . . .                     | <b>47</b> |
| 2.3.1      | Witten's perturbation . . . . .                                      | 47        |
| 2.3.2      | De Rham operators on a cone . . . . .                                | 48        |
| 2.3.3      | Witten's perturbation on a cone . . . . .                            | 50        |
| <b>2.4</b> | <b>Splitting of the Witten's complex on a cone</b> . . . . .         | <b>51</b> |
| 2.4.1      | Spectral decomposition on the link of the cone . . . . .             | 51        |
| 2.4.2      | Subcomplexes of length one . . . . .                                 | 51        |
| 2.4.3      | Subcomplexes of length two . . . . .                                 | 53        |
| 2.4.4      | Splitting into subcomplexes . . . . .                                | 55        |
| <b>2.5</b> | <b>Relatively local model of the Witten's perturbation</b> . . . . . | <b>58</b> |
| <b>2.6</b> | <b>Proof of Theorem 1.6.1</b> . . . . .                              | <b>60</b> |
| <b>2.7</b> | <b>Functional calculus</b> . . . . .                                 | <b>60</b> |
| <b>2.8</b> | <b>The wave operator</b> . . . . .                                   | <b>60</b> |
| <b>2.9</b> | <b>Proof of Theorem 1.6.2</b> . . . . .                              | <b>62</b> |

In this chapter, consider the notation of Sections 1.1, 1.2, 1.3 and 1.4. Then for a Riemannian manifold  $M$ , let  $\Omega_0(M)$  be the space of compactly supported differential forms, and  $L^2\Omega(M)$  the graded Hilbert space of square integrable differential forms. Let  $d$  and  $\delta$  be the de Rham derivative and coderivative acting on  $\Omega_0(M)$ , and let  $D = d + \delta$  and  $\Delta = D^2 = d\delta + \delta d$  (the Laplacian). Every Hilbert complex extension  $\mathbf{d}$  of  $d$  in  $L^2\Omega(M)$  is called an *ideal boundary condition (i.b.c.)*, giving rise to self-adjoint extensions  $\mathbf{D}$  and  $\mathbf{\Delta}$  of  $D$  and  $\Delta$  in  $L^2\Omega(M)$ . There exists a minimum/maximum i.b.c.,  $d_{\min} = \bar{d}$  and  $d_{\max} = \delta^*$ , inducing self-adjoint extensions  $D_{\max/\min}$  and  $\Delta_{\max/\min}$  of  $D$  and  $\Delta$ . If  $M$  is oriented, then  $\Delta_{\max}$  corresponds to  $\Delta_{\min}$  by the Hodge star operator. The corresponding cohomologies,  $H_{\max/\min}(M)$ , are quasi-isometric invariants of  $M$ ; for instance,  $H_{\max}(M)$  is the usual  $L^2$ -cohomology  $H_{(2)}(M)$ . They give rise to versions of Betti numbers and Euler characteristic,  $\beta_{\max/\min}^r(M)$  and  $\chi_{\max/\min}(M)$  (assuming finite dimension of the corresponding cohomologies).

In this chapter, the spaces under consideration are Thom-Mather stratifications. They are Hausdorff, locally compact and second countable spaces equipped with a partition into  $C^\infty$  manifolds called strata, and satisfying certain “gluing” conditions. Given a stratification  $A$ , an order relation on the family of strata is defined by declaring  $X \leq Y$  when  $X \subset \bar{Y}$ . With respect to this ordering, the maximum length of chains of strata less or equal than a stratum  $X$  is called the depth of  $X$ . Recall that the cone with link a stratification  $L$  is defined by  $c(L) = (L \times [0, \infty)) / (L \times \{0\})$ . A conic bundle over a manifold is a bundle that has a cone as typical fiber. Stratified spaces are locally described by charts constructed from conic bundles over their strata, called tube representatives. The possible decomposition of a cone into a product of cones leads to the concept of general tube representative of  $X$ . Then a general chart centered at a point of  $X$  is an open subset of a product space of the type  $\mathbb{R}^{m_X} \times \prod_{i=1}^{a_X} c(L_{X,i})$ . It can be assumed without loss of generality the existence of a dense stratum  $M$ , called the regular stratum. Moreover, if at every depth inductive step of the construction only stratifications with no strata of codimension 1 are admitted, then  $A$  is called a pseudomanifold.

It can be defined a general adapted metric  $g$  on  $M$  by induction on the depth. It is any (Riemannian) metric if  $\text{depth } M = 0$ . Now, assume  $\text{depth } M > 0$  and that general adapted metrics are defined for lower depth. Take any general adapted metric  $\tilde{g}$  on every dense stratum  $N$  of a compact stratification  $L$  such that  $\text{depth } L < \text{depth } M$ . Then, associated to a general chart,  $g$  is given by  $\sum_{i=0}^{a_X} g_i$ , where  $g_0$  is the Euclidean metric on  $\mathbb{R}^{m_X}$  and  $g_i = \rho_{X,i}^{2u_{X,i}} \tilde{g}_i + (d\rho_{X,i})^2$  on  $N_i \times \mathbb{R}_+$ , for some  $u_{X,i} > 0$ . If every  $u_{X,i} \leq 1$ , then  $g$  is called good. This is the kind of general adapted metrics considered in this chapter. Other restrictions of this metrical concept define adapted metrics and adapted metrics of conic type.

A smooth function  $f$  on  $M$  is called rel-admissible when the functions  $f$ ,  $|df|$  and  $|\text{Hess } f|$  are rel-bounded. In this case,  $f$  may not have any continuous extension to  $\overline{M} = A$ , but it has a continuous extension to the rel-local metric completion  $\widehat{M}$ . So it makes sense to say that  $x \in \widehat{M}$  is a rel-critical point of  $f$  when  $\liminf |df(y)| = 0$  as  $y \rightarrow x$  in  $\widehat{M}$ , with  $y \in M$ . It is said that  $f$  is a rel-Morse function if it is rel-admissible and verifies certain local description around every rel-critical point.

The aim of this chapter is to present the proof of Theorems 1.6.1 and 1.6.2. The first one gives the discrete character of the spectrum of  $\Delta_{\max/\min}$  and a version of Weyl's asymptotic formula for its eigenvalues. The second theorem consists on a version of Morse inequalities for rel-Morse functions. An application of this result to the context of intersection homology appears in Section 1.7. The contents of this chapter are included in [7].

## 2.1 Preliminaries

### 2.1.1 Products of cones

Let  $L$  and  $L'$  be compact stratifications, and let  $*$  and  $\rho$ , and  $*'$  and  $\rho'$  be the vertices and radial functions of  $c(L)$  and  $c(L')$ . Any morphism  $\psi : c(L) \rightarrow c(L')$  is of the form  $c(\phi)$  around  $*$  for some morphism  $\phi : L \rightarrow L'$ . In particular,  $\psi(*) = *'$ , and  $\psi^*\rho' = \rho$  around  $*$ .

The product of two stratifications,  $A \times A'$ , has a stratification structure whose strata are the products of strata of  $A$  and  $A'$ . However the tubes in  $A \times A'$  depend on the choice of certain function  $h : [0, \infty)^2 \rightarrow [0, \infty)$  (see Appendix A.1.2). Thus the stratification structure of  $A \times A'$  is not unique.

In the case of two cones,  $c(L) \times c(L')$  can be described as another cone in the following way [5, Lemma 3.8]. The function  $h(\rho \times \rho') : c(L) \times c(L') \rightarrow [0, \infty)$  satisfies that  $L'' = (h(\rho \times \rho'))^{-1}(1)$  is a compact saturated substratification of  $c(L) \times c(L')$ . Then the map

$$\phi : c(L'') \rightarrow c(L) \times c(L'), \quad [([x, r], [x', r']), s] \mapsto ([x, rs], [x', r's]),$$

is an isomorphism of stratifications. The vertex of  $c(L'')$  is  $*'' = \phi^{-1}(*, *')$ , and its radial function is  $\rho'' = \phi^*(h(\rho \times \rho'))$ . Thus the radial function of  $c(L) \times c(L')$ ,  $(\rho^2 + \rho'^2)^{1/2}$ , does not correspond to  $\rho''$  via  $\phi$  if  $L \neq \emptyset \neq L'$ .

Assume that  $L \neq \emptyset \neq L'$ . Let  $N$  and  $N'$  be strata of  $L$  and  $L'$ , and let  $M = N \times \mathbb{R}_+$  and  $M' = N' \times \mathbb{R}_+$  be the corresponding strata of  $c(L)$  and  $c(L')$ . Take general adapted metrics  $\tilde{g}$  and  $\tilde{g}'$  on  $N$  and  $N'$ , and fix any  $u > 0$ . We get general adapted metrics  $g = \rho^{2u}\tilde{g} + (d\rho)^2$  and  $g' = \rho'^{2u}\tilde{g}' + (d\rho')^2$  on  $M$  and  $M'$ . On the other hand, with the above notation, we have  $\phi^{-1}(M \times M') = N'' \times \mathbb{R}_+ =: M''$ ,

where  $N'' = (M \times M') \cap L''$  (a stratum of  $L''$ ). Let  $\tilde{g}''$  be any general adapted metric on  $N''$  so that  $N'' \hookrightarrow M \times M'$  is quasi-isometric; for instance, we may take  $\tilde{g}'' = (g + g')|_{N''}$ . We get the general adapted metric  $g'' = \rho''^{2u}\tilde{g}'' + (d\rho'')^2$  on  $M''$ . Equip  $M \times M'$  with  $g + g'$  and  $M''$  with  $g''$ .

**Proposition 2.1.1.** (i) *If  $u = 1$ , then  $\phi : M'' \rightarrow M \times M'$  is a quasi-isometry.*

(ii) *If  $u < 1$ , then  $\phi : M'' \cap O \rightarrow (M \times M') \cap \phi(O)$  is not quasi-isometric for any neighborhood  $O$  of  $*$ '' in  $c(L'')$ .*

*Proof.* Without lost of generality, we can assume  $\tilde{g}'' = (g + g')|_{N''}$ . We have

$$M'' = N'' \times \mathbb{R}_+ \subset M \times M' \times \mathbb{R}_+ = N \times \mathbb{R}_+ \times N' \times \mathbb{R}_+ \times \mathbb{R}_+.$$

According to this expression, an arbitrary point  $p \in M''$  can be written in the form  $p = (x, r, x', r', r'') \equiv (\bar{p}, r'')$ , obtaining

$$\phi(p) = (x, rr'', x', r'r'') \in M \times M' = N \times \mathbb{R}_+ \times N' \times \mathbb{R}_+.$$

Thus we can canonically consider

$$\begin{aligned} T_{\bar{p}}N'' &\subset T_x N \oplus \mathbb{R} \oplus T_{x'} N' \oplus \mathbb{R}, \\ T_p M'' &\subset T_x N \oplus \mathbb{R} \oplus T_{x'} N' \oplus \mathbb{R} \oplus \mathbb{R}, \\ T_{\phi(p)}(M \times M') &= T_x N \oplus \mathbb{R} \oplus T_{x'} N' \oplus \mathbb{R}. \end{aligned}$$

We easily get

$$\begin{aligned} \phi_*(\partial_{\rho''}(p)) &= (0, r\partial_\rho(rr''), 0, r'\partial_{\rho'}(r'r'')), \\ \phi_*(X, 0) &= (Y, cr''\partial_\rho(rr''), Y', c'r''\partial_{\rho'}(r'r'')), \end{aligned}$$

for  $X = (Y, c\partial_\rho(r), Y', c'\partial_{\rho'}(r')) \in T_{\bar{p}}N''$ . Hence

$$\|\partial_{\rho''}(p)\|_{g''}^2 = 1, \tag{2.1.1}$$

$$\|\phi_*(\partial_{\rho''}(p))\|_{g+g'}^2 = r^2 + r'^2, \tag{2.1.2}$$

$$\begin{aligned} \|(X, 0)\|_{g''}^2 &= r''^{2u} \|X\|_{\tilde{g}+g'}^2 \\ &= r''^{2u} \left( \|Y\|_{\tilde{g}}^2 + c^2 + \|Y'\|_{\tilde{g}'}^2 + c'^2 \right), \end{aligned} \tag{2.1.3}$$

$$\begin{aligned} \|\phi_*(X, 0)\|_{g+g'}^2 &= \left( r''^{2u} \|Y\|_{\tilde{g}}^2 + c^2 r''^{2u} + r''^{2u} \|Y'\|_{\tilde{g}'}^2 + c'^2 r''^{2u} \right) \\ &= r''^{2u} \left( \|Y\|_{\tilde{g}}^2 + c^2 r''^{2(1-u)} + \|Y'\|_{\tilde{g}'}^2 + c'^2 r''^{2(1-u)} \right), \end{aligned} \tag{2.1.4}$$

where every metric is added as subindex of the corresponding norm.

Observe that  $C_0 := \min_{N''}(\rho^2 + \rho'^2) > 0$  and  $C_1 := \max_{N''}(\rho^2 + \rho'^2) < \infty$  by the properties of  $h$ . So, by (2.1.1) and (2.1.2),

$$C_0 \|\partial_{\rho''}(p)\|_{g''}^2 \leq \|\phi_*(\partial_{\rho''}(p))\|_{g+g'}^2 \leq C_1 \|\partial_{\rho''}(p)\|_{g''}^2.$$

Moreover, if  $u = 1$ , then  $\|\phi_*(X, 0)\|_{g+g'}^2 = \|(X, 0)\|_{g''}^2$  by (2.1.3) and (2.1.4), obtaining (i).

Now, suppose that  $u < 1$ . With the above notation, by the conditions satisfied by  $h$ , we can take  $\bar{p} = (x, r, x', 1) \in N''$  and  $X = (0, \partial_\rho(r), 0, 0) \in T_{\bar{p}}N''$  for all  $r$  small enough. By (2.1.3) and (2.1.4), it follows that

$$\frac{\|\phi_*(X, 0)\|_{g+g'}^2}{\|(X, 0)\|_{g''}^2} = r''^{2(1-u)} \rightarrow 0$$

as  $r'' \rightarrow 0$ , giving (ii). □

Similar observations apply to the product of any finite number of cones.

## 2.1.2 General adapted metrics

Consider the notation of Section 1.3.

*Remark 2.1.2.* For  $m \in \mathbb{Z}_+$ , there is a canonical homeomorphism  $c(\mathbb{S}^{m-1}) \approx \mathbb{R}^m$ ,  $[x, \rho] \mapsto \rho x$ , so that the radial function  $\rho$  corresponds to the norm on  $\mathbb{R}^m$  [5, Example 3.7]. This is not an isomorphism of stratifications:  $c(\mathbb{S}^{m-1})$  has two strata and  $\mathbb{R}^m$  only one; the stratum  $\mathbb{S}^{m-1} \times \mathbb{R}_+$  of  $c(\mathbb{S}^{m-1})$  corresponds to  $\mathbb{R}^m \setminus \{0\}$ . If  $\tilde{g}$  denotes the standard metric on  $\mathbb{S}^{m-1}$ , then  $\rho^2 \tilde{g} + (d\rho)^2$  on  $\mathbb{S}^{m-1} \times \mathbb{R}_+$  corresponds to the Euclidean metric on  $\mathbb{R}^m \setminus \{0\}$ . Thus, with the notation of Chapter 1, the factors  $\mathbb{R}^{m,x}$  or  $\mathbb{R}^{m,\pm}$  could be also described as cones, or as strata of cones after removing one point.

*Remark 2.1.3.* By taking charts and using induction on the depth, we get the following (cf. [5, Remark 7]):

- (i) If two general adapted metrics on  $M$  have the same type with respect to the same general tubes, then they are rel-locally quasi-isometric. In particular, they are quasi-isometric if  $\overline{M}$  is compact.
- (ii) Any point in  $\overline{M}$  has a countable base  $\{O_m \mid m \in \mathbb{N}\}$  of open neighborhoods such that, with respect to any general adapted metric,  $\text{vol}(M \cap O_m) \rightarrow 0$  and  $\max\{\text{diam } P \mid P \in \pi_0(M \cap O_m)\} \rightarrow 0$  as  $m \rightarrow \infty$ . Thus, if  $\overline{M}$  is compact, then  $\text{vol } M < \infty$  and  $\text{diam } P < \infty$  for all  $P \in \pi_0(M)$ .

*Remark 2.1.4.* The argument of [13, Appendix] also shows the following. Let  $\{O_a\}$  be a locally finite open covering of  $\overline{M}$ , let  $\{\lambda_a\}$  be a smooth partition of unity of  $M$  subordinated to the open covering  $\{M \cap O_a\}$ , and let  $g_a$  be a general adapted metric on every  $M \cap O_a$ . Suppose that the metrics  $g_a$  have the same general type with respect to restrictions to the sets  $O_a$  of the same general tubes. Then the metric  $\sum_a \lambda_a g_a$  is general adapted on  $M$  and has the same general type with respect to those general tubes.

When  $M$  is not connected,  $\widehat{M}$  is defined as the disjoint union of the rel-local completion of the connected components of  $M$  (Section 1.3), making use of [5, Remark 1-(v)].

*Remark 2.1.5.* (i) By Remark 2.1.3-(i),  $\widehat{M}$  is independent of the choice of the general adapted metric of a given general type. In fact, by Remark 2.1.3-(ii) and [5, Example 3.19],  $\widehat{M}$  is also independent of the general type.

(ii) For any open  $O \subset A$ , we have  $\widehat{M \cap O} \equiv \lim^{-1}(\overline{M \cap O}) \subset \widehat{M}$ .

*Remark 2.1.6.* The following is a direct consequence of Remark 2.1.5-(i) and [5, Remark 9-(i),(ii) and Proposition 3.20-(iii)]:

- (i)  $\lim : \widehat{M} \rightarrow \overline{M}$  is surjective with finite fibers.
- (ii)  $M$  is rel-locally connected with respect to  $\widehat{M}$ .
- (iii) Let  $M'$  be a connected stratum of another stratification  $A'$  equipped with a general adapted metric, and let  $\phi : A \rightarrow A'$  be a morphism with  $\phi(M) \subset M'$ . Then the restriction  $\phi : M \rightarrow M'$  extends to a morphism  $\hat{\phi} : \widehat{M} \rightarrow \widehat{M}'$ . Moreover  $\hat{\phi}$  is an isomorphism if  $\phi$  is an isomorphism.

### 2.1.3 Relatively Morse functions

Consider the notation of Section 1.4. Besides the observations given in that section, the following holds like in the case of adapted metrics of conic type [5, Section 4].

*Remark 2.1.7.* (i) The rel-local boundedness of  $|df|$  is invariant by rel-local quasi-isometries, and therefore it depends only on the general type of  $g$ . Similarly, the definition of rel-critical point depends only on the general type of  $g$ . But the rel-local boundedness of  $|\text{Hess } f|$  depends on the choice of  $g$ . However it follows from (iv) and (v) below that the existence of  $g$  so that  $f$  is rel-admissible with respect to  $g$  is a rel-local property.

- (ii) If  $\text{depth } M = 0$ , then any smooth function is admissible, and its rel-critical points are its critical points.

- (iii) With the notation of Section 2.1.1, let  $h \in C^\infty(\mathbb{R}_+)$  with  $h' \in C_0^\infty(\mathbb{R}_+)$ . Then the function  $h(\rho)$  is rel-admissible on the stratum  $M$  of  $c(L)$  with respect to any general adapted metric.
- (iv) Let  $\{O_a \mid a \in \mathcal{A}\}$  be a locally finite covering of  $\overline{M}$  by open subsets of  $A$ . Then there is a  $C^\infty$  partition of unity  $\{\lambda_a\}$  on  $M$  subordinated to  $\{M \cap O_a\}$  such that  $|d\lambda_a|$  is rel-locally bounded for all general adapted metrics on  $M$  of any fixed general type.
- (v) Suppose that  $\{\lambda_a\}$  and  $\{g_a\}$  satisfy the conditions of Remark 2.1.4 and (iv). Let  $f \in C^\infty(M)$  such that every  $f|_{M \cap O_a}$  is rel-admissible with respect to  $g_a$ . Then  $f$  is rel-admissible with respect to the general adapted metric  $g = \sum_a \lambda_a g_a$  on  $M$ .
- (vi) Let  $\mathcal{F} \subset C^\infty(M)$  denote the subset of functions with continuous extensions to  $\overline{M}$  that restrict to rel-Morse functions with respect to all general adapted metrics of all possible general types on all strata  $\leq M$ . Then  $\mathcal{F}$  is dense in  $C^\infty(M)$  with the weak  $C^\infty$  topology.

### 2.1.4 Hilbert and elliptic complexes

Consider the notation of Section 1.1.

#### Hilbert complexes with a discrete positive spectrum

Let  $(D, d)$  be a Hilbert complex in a graded separable Hilbert space  $\mathfrak{H}$ , defining self-adjoint operators  $D$  and  $\Delta$  according to Section 1.1. The direct sum of homogeneous subspaces of even/odd degree are denoted with the subindex “ev/odd”. The same subindex is used to denote the restriction of homogeneous operators to such subspaces.

**Lemma 2.1.8.** *The positive spectrum of  $\Delta_{\text{ev}}$  is discrete<sup>1</sup> and bounded away from zero if and only if the positive spectrum of  $\Delta_{\text{odd}}$  is discrete and bounded away from zero. In this case, both operators have the same positive eigenvalues, with the same multiplicity.*

*Proof.* For instance, suppose that the positive spectrum of  $\Delta_{\text{ev}}$  is discrete and bounded away from zero. It follows from the spectral theorem that

$$D^\infty(\Delta_{\text{ev/odd}}) = \ker \Delta_{\text{ev/odd}} \oplus \Delta(D^\infty(\Delta_{\text{ev/odd}})),$$

<sup>1</sup>Recall that a complex number is in the discrete spectrum of a normal operator in a Hilbert space when it is an eigenvalue of finite multiplicity.

and

$$\mathbf{D}_{\text{ev}} : \Delta(\mathbf{D}^\infty(\Delta_{\text{ev}})) \rightarrow \Delta(\mathbf{D}^\infty(\Delta_{\text{odd}}))$$

is a linear isomorphism satisfying  $\mathbf{D}_{\text{ev}}\Delta_{\text{ev}} = \Delta_{\text{odd}}\mathbf{D}_{\text{ev}}$ . □

### Elliptic complexes with a term that is a direct sum

Let  $E = \bigoplus_r E_r$  be a graded Riemannian or Hermitian vector bundle over a Riemannian manifold  $M$ . The space of its smooth sections is denoted by  $C^\infty(E)$ , its subspace of compactly supported smooth sections is denoted by  $C_0^\infty(E)$ , and the Hilbert space of square integrable sections of  $E$  is denoted by  $L^2(E)$ . All of these are graded spaces. Consider differential operators of the same order,  $d_r : C^\infty(E_r) \rightarrow C^\infty(E_{r+1})$ , such that  $(C^\infty(E), d = \bigoplus_r d_r)$  is an elliptic<sup>2</sup> complex. The simpler notation  $(E, d)$  (or even  $d$ ) will be preferred. Elliptic complexes with nonzero terms of negative degrees or homogeneous differential operators of degree  $-1$  may be also considered without any essential change. For instance, we have the formal adjoint elliptic complex  $(E, \delta)$ .

Suppose that there is an orthogonal decomposition  $E_{r+1} = E_{r+1,1} \oplus E_{r+1,2}$  for some degree  $r + 1$ . Thus

$$\begin{aligned} C^\infty(E_{r+1}) &\equiv C^\infty(E_{r+1,1}) \oplus C^\infty(E_{r+1,2}), \\ C_0^\infty(E_{r+1}) &\equiv C_0^\infty(E_{r+1,1}) \oplus C_0^\infty(E_{r+1,2}), \\ L^2(E_{r+1}) &\equiv L^2(E_{r+1,1}) \oplus L^2(E_{r+1,2}), \end{aligned}$$

and we can write

$$\begin{aligned} d_r &= \begin{pmatrix} d_{r,1} \\ d_{r,2} \end{pmatrix}, & \delta_r &= (\delta_{r,1} \quad \delta_{r,2}), \\ d_{r+1} &= (d_{r+1,1} \quad d_{r+1,2}), & \delta_{r+1} &= \begin{pmatrix} \delta_{r+1,1} \\ \delta_{r+1,2} \end{pmatrix}. \end{aligned}$$

The operators  $d_{r,i}$  and  $\delta_{r,i}$  can be also considered as elliptic complexes of length one, and therefore they have a maximum/minimum i.b.c.,  $d_{r,i,\text{max/min}}$  and  $\delta_{r,i,\text{max/min}}$ .

**Lemma 2.1.9.** [5, Lemma 8.2] *We have:*

$$\mathbf{D}(d_{\text{max},r}) = \mathbf{D}(d_{r,1,\text{max}}) \cap \mathbf{D}(d_{r,2,\text{max}}), \quad d_{\text{max},r} = \left( \begin{array}{c|c} d_{r,1,\text{max}} & \mathbf{D}(d_{\text{max},r}) \\ \hline d_{r,2,\text{max}} & \mathbf{D}(d_{\text{max},r}) \end{array} \right).$$

---

<sup>2</sup>Recall that ellipticity means that the sequence of principal symbols of the operators  $d_r$  is exact over every nonzero cotangent vector.

**Lemma 2.1.10.** *We have:*

$$\mathbb{D}(d_{r+1,1,\max/\min}) \oplus \mathbb{D}(d_{r+1,2,\max/\min}) \subset \mathbb{D}(d_{\max/\min,r+1}). \quad (2.1.5)$$

*Proof.* Take any  $\begin{pmatrix} u \\ v \end{pmatrix} \in \mathbb{D}(d_{r+1,1,\min}) \oplus \mathbb{D}(d_{r+1,2,\min})$ , and let  $u' = d_{r+1,1,\min}u$  and  $v' = d_{r+1,2,\min}v$ . This means that there are sequences,  $u_i$  in  $C_0^\infty(E_{r+1,1})$  and  $v_i$  in  $C_0^\infty(E_{r+1,2})$ , such that  $u_i \rightarrow u$  in  $L^2(E_{r+1,1})$ ,  $v_i \rightarrow v$  in  $L^2(E_{r+1,2})$ ,  $d_{r+1,1}u_i \rightarrow u'$  and  $d_{r+1,2}v_i \rightarrow v'$  in  $L^2(E_{r+2})$ . So  $\begin{pmatrix} u_i \\ v_i \end{pmatrix} \in C_0^\infty(E_{r+1,1}) \oplus C_0^\infty(E_{r+1,2}) \equiv C_0^\infty(E_{r+1})$ ,  $\begin{pmatrix} u_i \\ v_i \end{pmatrix} \rightarrow \begin{pmatrix} u \\ v \end{pmatrix}$  in  $L^2(E_{r+1})$  and  $d_{r+1} \begin{pmatrix} u_i \\ v_i \end{pmatrix} \rightarrow u' + v'$  in  $L^2(E_{r+2})$ , obtaining  $\begin{pmatrix} u \\ v \end{pmatrix} \in \mathbb{D}(d_{\min,r+1})$ .

Now, take any  $\begin{pmatrix} u \\ v \end{pmatrix} \in \mathbb{D}(d_{r+1,1,\max}) \oplus \mathbb{D}(d_{r+1,2,\max})$ , and let  $u' = d_{r+1,1,\max}u$  and  $v' = d_{r+1,2,\max}v$ . This means that  $\langle u, \delta_{r+1,1}w \rangle = \langle u', w \rangle$  and  $\langle v, \delta_{r+1,2}w \rangle = \langle v', w \rangle$  for all  $w \in C_0^\infty(E_{r+2})$ . Thus  $\langle \begin{pmatrix} u \\ v \end{pmatrix}, \delta_{r+1}w \rangle = \langle u' + v', w \rangle$  for all  $w \in C_0^\infty(E_{r+2})$ , obtaining that  $\begin{pmatrix} u \\ v \end{pmatrix} \in \mathbb{D}(d_{\max,r+1})$ .  $\square$

## 2.2 Two simple types of elliptic complexes

Here, we study two simple elliptic complexes on  $\mathbb{R}_+$ , which will show up in a direct sum splitting of the rel-local model of Witten's perturbation (Section 2.4).

### 2.2.1 An elliptic complex of length one

Consider the standard metric on  $\mathbb{R}_+$ . Let  $E$  be the graded Riemannian/Hermitian vector bundle over  $\mathbb{R}_+$  whose nonzero terms are  $E_0$  and  $E_1$ , which are real/complex trivial line bundles equipped with the standard Riemannian/Hermitian metrics. Thus

$$\begin{aligned} C^\infty(E_0) &\equiv C_+^\infty \equiv C^\infty(E_1), \\ L^2(E_0) &\equiv L_+^2 \equiv L^2(E_1), \end{aligned}$$

where real/complex-valued functions are considered in  $C_+^\infty$  and  $L_+^2$ . For any fixed  $s > 0$  and  $\kappa \in \mathbb{R}$ , let

$$C^\infty(E_0) \begin{array}{c} \xleftarrow{d} \\ \xrightarrow{\delta} \end{array} C^\infty(E_1)$$

be the differential operators defined by

$$\begin{aligned} d &= \frac{d}{d\rho} - \kappa\rho^{-1} \pm s\rho, \\ \delta &= -\frac{d}{d\rho} - \kappa\rho^{-1} \pm s\rho. \end{aligned}$$

It is easy to check that  $(E, d)$  is an elliptic complex, and that<sup>3</sup>  $\delta = d^\dagger$ .

<sup>3</sup>The superindex  $\dagger$  is used to denote the formal adjoint.

### Self-adjoint operators defined by the Laplacian

By (4.7.1), the homogeneous components of  $\Delta$  (or  $\Delta^\pm$ ) are:

$$\Delta_0 = H + \kappa(\kappa - 1)\rho^{-2} \mp s(1 + 2\kappa), \tag{2.2.1}$$

$$\Delta_1 = H + \kappa(\kappa + 1)\rho^{-2} \pm s(1 - 2\kappa), \tag{2.2.2}$$

where  $H$  is the harmonic oscillator on  $C_+^\infty$  defined with the constant  $s$ . Then  $\Delta_0$  and  $\Delta_1$  are like  $P_0$  and  $Q_0$  in (4.7.2), with  $c_1 = 0 = d_1$ , plus a constant. Thus, by Propositions 4.7.1 and 4.7.2,  $\Delta_0$  and  $\Delta_1$  define the self-adjoint operators  $\mathcal{A}_i$  and  $\mathcal{B}_i$  in  $L_+^2$  indicated in Table 2.1, where the conditions come from (4.7.4) and (4.7.7). The notation  $\mathcal{A}_i^\pm$  and  $\mathcal{B}_i^\pm$  may be used as well to specify that these operators are defined by  $\Delta_0^\pm$  and  $\Delta_1^\pm$ . In these cases, we have  $c_1 = d_1 = 0$ , and therefore  $\sigma = a$  and  $\tau = b$ , which are given by (4.7.3) and (4.7.6).

|            |                 | $\sigma$     | $\tau$        | Condition               |
|------------|-----------------|--------------|---------------|-------------------------|
| $\Delta_0$ | $\mathcal{A}_1$ | $\kappa$     |               | $\kappa > -\frac{1}{2}$ |
|            | $\mathcal{A}_2$ | $1 - \kappa$ |               | $\kappa < \frac{3}{2}$  |
| $\Delta_1$ | $\mathcal{B}_1$ |              | $\kappa$      | $\kappa > -\frac{3}{2}$ |
|            | $\mathcal{B}_2$ |              | $-1 - \kappa$ | $\kappa < \frac{1}{2}$  |

Table 2.1: Self-adjoint operators defined by  $\Delta_0$  and  $\Delta_1$ .

There are the following overlaps in Table 2.1:

- Both  $\mathcal{A}_1$  and  $\mathcal{A}_2$  are defined if  $-\frac{1}{2} < \kappa < \frac{3}{2}$ , and they are equal just when  $\kappa = \frac{1}{2}$ .
- Both  $\mathcal{B}_1$  and  $\mathcal{B}_2$  are defined if  $-\frac{3}{2} < \kappa < \frac{1}{2}$ , and they are equal just when  $\kappa = -\frac{1}{2}$ .

The cores of  $\mathcal{A}_i$  and  $\mathcal{B}_i$ , given by Propositions 4.7.1 and 4.7.2, will be denoted by  $\mathcal{E}_i^0$  and  $\mathcal{E}_i^1$ , respectively. Note that the graded subspace  $\mathcal{E}_i = \mathcal{E}_i^0 \oplus \mathcal{E}_i^1$  of  $C^\infty(E) \cap L^2(E)$ , whenever defined, is preserved by  $D = d + \delta$ . Propositions 4.7.1 and 4.7.2 also describe the spectra of  $\mathcal{A}_i$  and  $\mathcal{B}_i$ :

- The spectrum of  $\mathcal{A}_1$  consists of the eigenvalues

$$(2k + (1 \mp 1)(1 + 2\kappa))s \quad (k \in 2\mathbb{N}) \tag{2.2.3}$$

of multiplicity one.

- The spectrum of  $\mathcal{A}_2$  consists of the eigenvalues

$$(2k + 4 - (1 \pm 1)(1 + 2\kappa))s \quad (k \in 2\mathbb{N}) \quad (2.2.4)$$

of multiplicity one.

- The spectrum of  $\mathcal{B}_1$  consists of the eigenvalues

$$(2k + 2 + (1 \mp 1)(-1 + 2\kappa))s \quad (k \in 2\mathbb{N} + 1) \quad (2.2.5)$$

of multiplicity one.

- The spectrum of  $\mathcal{B}_2$  consists of the eigenvalues

$$(2k - 2 - (1 \pm 1)(-1 + 2\kappa))s \quad (k \in 2\mathbb{N} + 1) \quad (2.2.6)$$

of multiplicity one.

These eigenvalues have normalized eigenfunctions  $\chi_k$ , defined for the corresponding values of  $a = \sigma$  and  $b = \tau$ . For  $\mathcal{A}_1^+$ , (2.2.3) becomes  $2ks$ . For  $\mathcal{A}_1^-$ , (2.2.3) is  $2(k + 1 + 2\kappa)s$ . For  $\mathcal{A}_2^+$ , (2.2.4) becomes  $2(k + 1 - 2\kappa)s$ . For  $\mathcal{A}_2^-$ , (2.2.4) is  $2(k + 2)s$ . For  $\mathcal{B}_1^+$ , (2.2.5) is  $2(k + 1)s$ . For  $\mathcal{B}_1^-$ , (2.2.5) becomes  $2(k + 2\kappa)s$ . For  $\mathcal{B}_2^+$ , (2.2.6) is  $2(k - 2\kappa)s$ . For  $\mathcal{B}_2^-$ , (2.2.6) becomes  $2(k - 1)s$ . Using this, we get the information about the sign of the eigenvalues of  $\mathcal{A}_i$  and  $\mathcal{B}_i$  given in Table 2.2. In the tables, grey color is used for cases that will be disregarded later (for instance, if there may exist some negative eigenvalue), and a question mark is used for unknown information.

### Laplacians of the maximum/minimum i.b.c.

**Proposition 2.2.1.** [5, Proposition 8.4] *Table 2.3 describes  $\Delta_{\max/\min}$ .*

*Remark 2.2.2.* (i) In [5], the proof of Proposition 2.2.1 uses the following property [5, Lemma 8.5]. Suppose that either  $\theta > \frac{1}{2}$ , or  $\theta = \frac{1}{2} = \kappa$  (respectively,  $\theta = \frac{1}{2} = -\kappa$ ). Then, for every  $\xi \in \rho^\theta \mathcal{S}_{\text{ev},+}$ , considered as subspace of  $C^\infty(E_0)$  (respectively,  $C^\infty(E_1)$ ), there is a sequence  $(\xi_n)$  in  $C_0^\infty(E_0)$  (respectively,  $C_0^\infty(E_1)$ ), independent of  $\kappa$ , such that  $\lim_n \xi_n = \xi$  in  $L^2(E_0)$  (respectively,  $L^2(E_1)$ ) and  $\lim_n d\xi_n = d\xi$  in  $L^2(E_1)$  (respectively,  $\lim_n \delta\xi_n = \delta\xi$  in  $L^2(E_0)$ ). In particular,  $\rho^\theta \mathcal{S}_{\text{ev},+}$  is contained in  $D(d_{\min})$  (respectively,  $D(\delta_{\min})$ ). Moreover, according to the proof of [5, Lemma 8.5], given  $0 < a < b$ , we can take  $\xi_n = \alpha_n \xi$  for some  $\alpha_n \in C_+^\infty$  satisfying  $\chi_{[\frac{b}{n}, na]} \leq \alpha_n \leq \chi_{[\frac{a}{n}, nb]}$ , where  $\chi_S$  denotes the characteristic function of every subset  $S \subset \mathbb{R}_+$ .

- (ii)  $\mathcal{E}_i^0$  (respectively,  $\mathcal{E}_i^1$ ) is also a core of  $d_{\max/\min}$  (respectively,  $\delta_{\min/\max}$ ) when  $\Delta_{\max/\min,0} = \mathcal{A}_i$  (respectively,  $\Delta_{\max/\min,1} = \mathcal{B}_i$ ).

|                   |                        | Sign of eigenvalues  |                   |                                   | Sign of eigenvalues   |
|-------------------|------------------------|--|-------------------|-----------------------------------|---|
| $\mathcal{A}_1^+$ |                        | 0 if $k = 0$<br>+ if $k \geq 2$ even                                       | $\mathcal{B}_1^+$ |                                   | + $\forall k \in 2\mathbb{N} + 1$                                 |
| $\mathcal{A}_1^-$ |                        | + $\forall k \in 2\mathbb{N}$  | $\mathcal{B}_1^-$ | $\kappa > -\frac{1}{2}$           | + $\forall k \in 2\mathbb{N} + 1$                                 |
| $\mathcal{A}_2^+$ | $\kappa > \frac{1}{2}$ | - if $k < 2\kappa - 1$<br>0 if $k = 2\kappa - 1$<br>+ if $k > 2\kappa - 1$ |                   | $\kappa = -\frac{1}{2}$           | 0 if $k = 1$<br>+ if $k \geq 3$ odd                               |
|                   | $\kappa = \frac{1}{2}$ | 0 if $k = 0$<br>+ if $k \geq 2$ even                                       |                   | $\kappa < -\frac{1}{2}$           | - if $k < -2\kappa$<br>0 if $k = -2\kappa$<br>+ if $k > -2\kappa$ |
|                   | $\kappa < \frac{1}{2}$ | + $\forall k \in 2\mathbb{N}$  | $\mathcal{B}_2^+$ | + $\forall k \in 2\mathbb{N} + 1$ |   |
| $\mathcal{A}_2^-$ |                        | + $\forall k \in 2\mathbb{N}$  | $\mathcal{B}_2^-$ |                                   | 0 if $k = 1$<br>+ if $k \geq 3$ odd                               |

 Table 2.2: Sign of the eigenvalues of  $\mathcal{A}_i$  and  $\mathcal{B}_i$ .

### 2.2.2 An elliptic complex of length two

Consider again the standard metric on  $\mathbb{R}_+$ . Let  $F$  be the graded Riemannian/Hermitian vector bundle over  $\mathbb{R}_+$  whose nonzero terms are  $F_0$ ,  $F_1$  and  $F_2$ , which are trivial real/complex vector bundles of ranks 1, 2 and 1, respectively, equipped with the standard Riemannian/Hermitian metrics. Thus

$$\begin{aligned}
 C^\infty(F_0) &\equiv C_+^\infty \equiv C^\infty(F_2), & C^\infty(F_1) &\equiv C_+^\infty \oplus C_+^\infty, \\
 L^2(F_0) &\equiv L_+^2 \equiv L^2(F_2), & L^2(F_1) &\equiv L_+^2 \oplus L_+^2,
 \end{aligned}$$

where real/complex-valued functions are considered in  $C_+^\infty$  and  $L_+^2$ . Fix  $s, \mu > 0$ ,  $0 < u < 1$  and  $\kappa \in \mathbb{R}$ . Let

$$\begin{array}{ccccc}
 C^\infty(F_0) & \xleftrightarrow[\delta_0 \equiv (\delta_{0,1} \quad \delta_{0,2})]{d_0 \equiv \begin{pmatrix} d_{0,1} \\ d_{0,2} \end{pmatrix}} & C^\infty(F_1) & \xleftrightarrow[\delta_1 \equiv \begin{pmatrix} \delta_{1,1} \\ \delta_{1,2} \end{pmatrix}]{d_1 \equiv (d_{1,1} \quad d_{1,2})} & C^\infty(F_2)
 \end{array}$$

|                            | $\Delta_{\max,0}$ | $\Delta_{\min,0}$ | $\Delta_{\max,1}$ | $\Delta_{\min,1}$ |
|----------------------------|-------------------|-------------------|-------------------|-------------------|
| $\kappa \geq \frac{1}{2}$  | $\mathcal{A}_1$   |                   | $\mathcal{B}_1$   |                   |
| $ \kappa  < \frac{1}{2}$   | $\mathcal{A}_1$   | $\mathcal{A}_2$   | $\mathcal{B}_1$   | $\mathcal{B}_2$   |
| $\kappa \leq -\frac{1}{2}$ | $\mathcal{A}_2$   |                   | $\mathcal{B}_2$   |                   |

 Table 2.3: Description of  $\Delta_{\max/\min}$ .

be the differential operators defined by

$$\begin{aligned}
 d_{0,1} &= \mu\rho^{-u}, & d_{0,2} &= \frac{d}{d\rho} - (\kappa + u)\rho^{-1} \pm s\rho, \\
 d_{1,1} &= \frac{d}{d\rho} - \kappa\rho^{-1} \pm s\rho, & d_{1,2} &= -\mu\rho^{-u}, \\
 \delta_{0,1} &= \mu\rho^{-u}, & \delta_{0,2} &= -\frac{d}{d\rho} - (\kappa + u)\rho^{-1} \pm s\rho, \\
 \delta_{1,1} &= -\frac{d}{d\rho} - \kappa\rho^{-1} \pm s\rho, & \delta_{1,2} &= -\mu\rho^{-u}.
 \end{aligned}$$

Observe that  $\delta_0 = d_0^\dagger$  and  $\delta_1 = d_1^\dagger$ . We may also use the more explicit notation  $d_r^\pm$ ,  $\delta_r^\pm$ ,  $d_{r,i}^\pm$  and  $\delta_{r,i}^\pm$ . A direct computation shows that  $d_0$  and  $d_1$  define an elliptic complex  $(F, d)$  of length two. Note that, by (4.7.1),

$$d_{1,1} = \rho^{-u} d_{0,2} \rho^u, \quad \delta_{0,2} = \rho^{-u} \delta_{1,1} \rho^u. \quad (2.2.7)$$

### Self-adjoint operators defined by the Laplacian

By (4.7.1), the homogeneous components of the corresponding Laplacian  $\Delta$  (or  $\Delta^\pm$ ) are given by

$$\begin{aligned}
 \Delta_0 &= H + (\kappa + u)(\kappa + u - 1)\rho^{-2} + \mu^2\rho^{-2u} \mp s(1 + 2(\kappa + u)), \\
 \Delta_2 &= H + \kappa(\kappa + 1)\rho^{-2} + \mu^2\rho^{-2u} \pm s(1 - 2\kappa), \\
 \Delta_1 &= \begin{pmatrix} \Delta_{1,1} & -2\mu u\rho^{-u-1} \\ -2\mu u\rho^{-u-1} & \Delta_{1,2} \end{pmatrix}, \\
 \Delta_{1,1} &= H + \kappa(\kappa - 1)\rho^{-2} + \mu^2\rho^{-2u} \mp s(1 + 2\kappa), \\
 \Delta_{1,2} &= H + (\kappa + u)(\kappa + u + 1)\rho^{-2} + \mu^2\rho^{-2u} \pm s(1 - 2(\kappa + u)).
 \end{aligned}$$

(We may also use (2.2.1) and (2.2.2) to compute easily some parts of the above components of  $\Delta$ .) The operators  $\Delta_0$ ,  $\Delta_2$ ,  $\Delta_{1,1}$  and  $\Delta_{1,2}$  are like  $P$  and  $Q$  in (4.7.15), with  $c_1 = 0 = d_1$ , plus a constant term. Write  $\Delta_1 = U \mp sV$ , where

$$V = \begin{pmatrix} 1 + 2\kappa & 0 \\ 0 & -1 + 2(\kappa + u) \end{pmatrix}. \quad (2.2.8)$$

Then, by Corollaries 4.7.3, 4.7.4 and 4.7.5, and Remark 4.7.6-(v),  $\Delta_0$ ,  $\Delta_2$  and  $\Delta_1$  define the self-adjoint operators  $\mathcal{P}_i$  and  $\mathcal{Q}_j$  in  $L_+^2$ , and  $\mathcal{W}_{i,j}$  in  $L_+^2 \oplus L_+^2$ , indicated in Table 2.4, where the conditions come from (4.7.9), (4.7.11), (4.7.13) and (1.10.5)–(1.10.8). The notation  $\mathcal{P}_i^\pm$ ,  $\mathcal{Q}_j^\pm$  and  $\mathcal{W}_{i,j}^\pm$  may be used as well to specify that these operators are defined by  $\Delta_0^\pm$ ,  $\Delta_2^\pm$  and  $\Delta_1^\pm$ . Note that  $v = u$  for all  $\mathcal{W}_{i,j}$ . The cores of  $\mathcal{P}_i^{1/2}$ ,  $\mathcal{Q}_j^{1/2}$  and  $\mathcal{W}_{i,j}^{1/2}$ , given by Corollaries 4.7.3, 4.7.4 and 4.7.5, will be denoted by  $\mathcal{F}_i^0$ ,  $\mathcal{F}_j^2$  and  $\mathcal{F}_{i,j}^1 = \mathcal{F}_i^{1,1} \oplus \mathcal{F}_j^{1,2}$ , respectively.

*Remark 2.2.3.* In contrast to  $\mathcal{E}_i$  in Section 2.2.1, note that the graded subspace  $\mathcal{F}_i^0 \oplus \mathcal{F}_{i,j}^1 \oplus \mathcal{F}_j^2$  of  $C^\infty(F) \cap L^2(F)$ , whenever defined, is not preserved by  $D = d + \delta$ . For instance, it is preserved by  $d$  but not by  $\delta$  when  $i = j = 1$ , and it is preserved by  $\delta$  but not by  $d$  when  $i = j = 2$ .

|            |                           | $\sigma$         | $\tau$            | $\theta$           | Condition                                     |
|------------|---------------------------|------------------|-------------------|--------------------|---|
| $\Delta_0$ | $\mathcal{P}_1$           | $\kappa + u$     |                   |                    | $\kappa > -\frac{1}{2}$                       |
|            | $\mathcal{P}_2$           | $1 - \kappa - u$ |                   |                    | $\kappa < \frac{3}{2} - 2u$                   |
| $\Delta_2$ | $\mathcal{Q}_1$           |                  | $\kappa$          |                    | $\kappa > u - \frac{3}{2}$                    |
|            | $\mathcal{Q}_2$           |                  | $-1 - \kappa$     |                    | $\kappa < \frac{1}{2} - u$                    |
| $\Delta_1$ | $\mathcal{W}_{1,1}$       | $\kappa$         | $\kappa + u$      | $\kappa$           | $\kappa > u - \frac{1}{2}$                    |
|            | $\mathcal{W}_{2,2}$       | $1 - \kappa$     | $-1 - \kappa - u$ | $-\kappa - u$      | $\kappa < \frac{1}{2} - 2u$                   |
|            | $\beta \mathcal{W}_{1,2}$ | $\kappa$         | $-1 - \kappa - u$ | $-\frac{1}{2} - u$ | Impossible                                    |
|            | $\mathcal{W}_{2,1}$       | $1 - \kappa$     | $\kappa + u$      | $\frac{1}{2}$      | $-1 - \frac{u}{2} < \kappa < 1 - \frac{u}{2}$ |

Table 2.4: Self-adjoint operators defined by  $\Delta_0$ ,  $\Delta_2$  and  $\Delta_1$ .

Let us explain the contents of Table 2.4. Since  $c_1 = d_1 = 0$ , we have  $\sigma = a$  and  $\tau = b$ , which are given by (4.7.3) and (4.7.6). Moreover  $\sigma$ ,  $\tau$  and  $u$  determine  $\theta$  in Table 2.4 so that  $U$  is of the form (4.7.16) because  $2\theta - \sigma - \tau = -u$ . Let us check the conditions written in this table, which are given by the hypothesis of Corollaries 4.7.3–4.7.5. For  $\mathcal{P}_i$  and  $\mathcal{Q}_j$ , only (4.7.9) and (4.7.11) are required. For  $\mathcal{W}_{i,j}$ , we also require (4.7.13), and the hypothesis (a)–(d) of Theorem 1.10.3, obtaining the following:

- For  $\mathcal{W}_{1,1}$ , we have  $\sigma = \theta \neq \tau$  and  $\tau - \sigma = u \notin -\mathbb{N}$ . Thus (a) applies in this case. Note that (4.7.9), (4.7.11) and (4.7.13) mean  $\kappa > u - \frac{1}{2}$ . Then (1.10.5) holds because  $0 < u < 1$  and  $\kappa > u - \frac{1}{2}$ . So (a) is satisfied.

- For  $\mathcal{W}_{2,2}$ , we have  $\sigma \neq \theta = \tau + 1$  and  $\sigma - \tau - 1 = 1 + u \notin -\mathbb{N}$ . Thus (c) applies in this case. Now, (4.7.9), (4.7.11) and (4.7.13) mean  $\kappa < \frac{1}{2} - 2u$ . Then (1.10.7) holds because  $0 < u < 1$  and  $\kappa < \frac{1}{2} - 2u$ . So (c) is satisfied.
- There is no  $\mathcal{W}_{1,2}$  because  $\theta < -\frac{1}{2}$  in that case.
- For  $\mathcal{W}_{2,1}$ , (4.7.9), (4.7.11) and (4.7.13) mean  $-\frac{3}{2} < \kappa < \frac{3}{2} - u$ , and we have the following possibilities:
  - The case  $\sigma = \theta = \tau$  is not possible because  $u \neq 0$ .
  - The case  $\sigma = \theta \neq \tau$  happens when  $\kappa = \frac{1}{2}$ . Then  $\sigma = \frac{1}{2}$  and  $\tau = \frac{1}{2} + u$ , obtaining  $\tau - \sigma = u \notin -\mathbb{N}$ . Thus (a) applies in this case. Moreover (1.10.5) holds because  $0 < u < 1$ . So (a) is satisfied.
  - The case  $\sigma \neq \theta = \tau$  happens when  $\kappa = \frac{1}{2} - u$ . Then  $\sigma = \frac{1}{2} + u$  and  $\tau = \frac{1}{2}$ , obtaining  $\sigma - \tau = u \notin -\mathbb{N}$ . Thus (b) applies in this case. Moreover (1.10.6) holds because  $0 < u < 1$ . Hence (b) is satisfied.
  - The case  $\sigma \neq \theta = \tau + 1$  happens when  $\kappa = -\frac{1}{2} - u$ . Then  $\sigma = \frac{3}{2} + u$  and  $\tau = -\frac{1}{2}$ , obtaining  $\sigma - \tau - 1 = 1 + u \notin -\mathbb{N}$ . Thus (c) applies in this case. Moreover (1.10.7) holds because  $0 < u < 1$ . Hence (c) is satisfied.
  - Finally, assume that  $\sigma \neq \theta \neq \tau$ . The condition  $\sigma - \theta, \tau - \theta \notin -\mathbb{N}$  means that  $\kappa \notin (\frac{1}{2} + \mathbb{N}) \cup (\frac{1}{2} - u - \mathbb{N})$ , which in turn means that  $\kappa \neq \frac{1}{2}, \frac{1}{2} - u, -\frac{1}{2} - u$  because  $-\frac{3}{2} < \kappa < \frac{3}{2} - u$ . But  $\sigma = \theta$  if  $\kappa = \frac{1}{2}$ ,  $\tau = \theta$  if  $\kappa = \frac{1}{2} - u$ , and  $\theta = \tau + 1$  if  $\kappa = -\frac{1}{2} - u$ , as we have seen in the previous cases. So  $\sigma - \theta, \tau - \theta \notin -\mathbb{N}$ , and (d) applies in this case. Moreover, since  $0 < u < 1$ , (1.10.8) holds just when  $-1 - \frac{u}{2} < \kappa < 1 - \frac{u}{2}$ . Thus (d) is satisfied assuming the stated conditions on  $\kappa$ .

Therefore  $\mathcal{W}_{2,1}$  is defined in one of the above ways if  $-1 - \frac{u}{2} < \kappa < 1 - \frac{u}{2}$ .

There are the following overlaps of the conditions in Table 2.4:

- Both  $\mathcal{P}_1$  and  $\mathcal{P}_2$  are defined for  $-\frac{1}{2} < \kappa < \frac{3}{2} - 2u$ , and  $\mathcal{P}_1 = \mathcal{P}_2$  just when  $\kappa = \frac{1}{2} - u$ .
- Both  $\mathcal{Q}_1$  and  $\mathcal{Q}_2$  are defined for  $u - \frac{3}{2} < \kappa < \frac{1}{2} - u$ , and  $\mathcal{Q}_1 = \mathcal{Q}_2$  just when  $\kappa = -\frac{1}{2}$ .
- Both  $\mathcal{W}_{1,1}$  and  $\mathcal{W}_{2,2}$  are defined for  $u - \frac{1}{2} < \kappa < \frac{1}{2} - 2u$  (if  $u < \frac{1}{3}$ ), but  $\mathcal{W}_{1,1} \neq \mathcal{W}_{2,2}$  for all such  $\kappa$ .
- Both  $\mathcal{W}_{1,1}$  and  $\mathcal{W}_{2,1}$  are defined for  $u - \frac{1}{2} < \kappa < 1 - \frac{u}{2}$ , and  $\mathcal{W}_{1,1} = \mathcal{W}_{2,1}$  just when  $\kappa = \frac{1}{2}$ .

- Both  $\mathcal{W}_{2,2}$  and  $\mathcal{W}_{2,1}$  are defined for  $-1 - \frac{u}{2} < \kappa < \frac{1}{2} - 2u$ , and  $\mathcal{W}_{2,2} = \mathcal{W}_{2,1}$  just when  $\kappa = -\frac{1}{2} - u$ .

Corollaries 4.7.3, 4.7.4 and 4.7.5 also give the following spectral estimates, for all  $\epsilon > 0$ :

- The spectrum of  $\mathcal{P}_1$  consists of eigenvalues  $\lambda_0 \leq \lambda_2 \leq \dots$ , taking multiplicity into account, such that there are  $D = D(\kappa, u) > 0$  and  $C = C(\epsilon, \kappa, u) > 0$  so that, for all  $k \in 2\mathbb{N}$ ,

$$\lambda_k \geq (2k + (1 \mp 1)(1 + 2(\kappa + u)))s + \mu^2 D s^u (k + 1)^{-u}, \quad (2.2.9)$$

$$\begin{aligned} \lambda_k \leq & (2k + (1 \mp 1)(1 + 2(\kappa + u)))s \\ & + (2k + 1 + 2(\kappa + u))\mu^2 \epsilon s^u + \mu^2 C s^u. \end{aligned} \quad (2.2.10)$$

The first term of the right-hand side of (2.2.9) and (2.2.10) for  $\mathcal{P}_1^+$  and  $\mathcal{P}_1^-$  is  $2ks$  and  $2(k + 1 + 2(\kappa + u))s$ , respectively.

- The spectrum of  $\mathcal{P}_2$  consists of eigenvalues  $\lambda_0 \leq \lambda_2 \leq \dots$ , taking multiplicity into account, such that there are  $D = D(\kappa, u) > 0$  and  $C = C(\epsilon, \kappa, u) > 0$  so that, for all  $k \in 2\mathbb{N}$ ,

$$\lambda_k \geq (2k + 4 - (1 \pm 1)(1 + 2(\kappa + u)))s + \mu^2 D s^u (k + 1)^{-u}, \quad (2.2.11)$$

$$\begin{aligned} \lambda_k \leq & (2k + 4 - (1 \pm 1)(1 + 2(\kappa + u)))s \\ & + (2k + 3 - 2(\kappa + u))\mu^2 \epsilon s^u + \mu^2 C s^u. \end{aligned} \quad (2.2.12)$$

The first term of the right-hand side of (2.2.11) and (2.2.12) for  $\mathcal{P}_2^+$  and  $\mathcal{P}_2^-$  becomes  $2(k + 1 - 2(\kappa + u))s$  and  $2(k + 2)s$ , respectively.

- The spectrum of  $\mathcal{Q}_1$  consists of eigenvalues  $\lambda_1 \leq \lambda_3 \leq \dots$ , taking multiplicity into account, such that there are  $D = D(\kappa, u) > 0$  and  $C = C(\epsilon, \kappa, u) > 0$  so that, for all  $k \in 2\mathbb{N} + 1$ ,

$$\lambda_k \geq (2k + 2 - (1 \mp 1)(1 - 2\kappa))s + \mu^2 D s^u (k + 1)^{-u}, \quad (2.2.13)$$

$$\begin{aligned} \lambda_k \leq & (2k + 2 - (1 \mp 1)(1 - 2\kappa))s \\ & + (2k + 1 + 2\kappa)\mu^2 \epsilon s^u + \mu^2 C s^u. \end{aligned} \quad (2.2.14)$$

The first term of the right-hand side of (2.2.13) and (2.2.14) for  $\mathcal{Q}_1^+$  and  $\mathcal{Q}_1^-$  is  $2(k + 1)s$  and  $2(k + 2\kappa)s$ , respectively.

- The spectrum of  $\mathcal{Q}_2$  consists of eigenvalues  $\lambda_1 \leq \lambda_3 \leq \dots$ , taking multiplicity into account, such that there are  $D = D(\kappa, u) > 0$  and  $C = C(\epsilon, \kappa, u) > 0$  so

that, for all  $k \in 2\mathbb{N} + 1$ ,

$$\lambda_k \geq (2k - 2 + (1 \pm 1)(1 - 2\kappa))s + \mu^2 D s^u (k + 1)^{-u}, \quad (2.2.15)$$

$$\begin{aligned} \lambda_k &\leq (2k - 2 + (1 \pm 1)(1 - 2\kappa))s \\ &\quad + (2k - 1 - 2\kappa)\mu^2 \epsilon s^u + \mu^2 C s^u. \end{aligned} \quad (2.2.16)$$

The first term of the right-hand side of (2.2.15) and (2.2.16) for  $\mathcal{Q}_2^+$  and  $\mathcal{Q}_2^-$  is  $2(k - 2\kappa)s$  and  $2(k - 1)s$ , respectively.

- For  $\mathcal{W}_{2,1}$ , we can take  $\tilde{u} = \frac{u+1}{2}$  satisfying (1.10.12). Moreover the maximum eigenvalue of  $\mp sV$  is  $s(1 \mp (2\kappa + u) - u)$ . Thus the spectrum of  $\mathcal{W}_{2,1}$  consists of two groups of eigenvalues,  $\lambda_0 \leq \lambda_2 \leq \dots$  and  $\lambda_1 \leq \lambda_3 \leq \dots$ , repeated according to multiplicity, such that there are some  $D = D(\kappa, u) > 0$ ,  $C = C(\epsilon, \kappa, u) > 0$ ,  $\tilde{C} = \tilde{C}(\epsilon, \kappa, u) > 0$  and  $E = E(\epsilon, \kappa) > 0$  so that, for all  $k \in 2\mathbb{N}$ ,

$$\begin{aligned} \lambda_k &\geq (1 - 2\mu\epsilon s^{\frac{u-1}{2}})(2k + 3 - 2\kappa)s \\ &\quad + \mu^2 D s^u (k + 1)^{-u} - 2\mu\tilde{C}s^{\frac{u+1}{2}} \mp (1 + 2\kappa)s, \end{aligned} \quad (2.2.17)$$

$$\begin{aligned} \lambda_k &\leq (2k + 4 - (1 \pm 1)(2\kappa + u))s \\ &\quad + (2k + 3 - 2\kappa)\epsilon(\mu^2 s^u + 4\mu u s^{\frac{u+1}{2}}) \\ &\quad + \mu^2 C s^u + 4\mu u E s^{\frac{u+1}{2}}, \end{aligned} \quad (2.2.18)$$

and, for all  $k \in 2\mathbb{N} + 1$ ,

$$\begin{aligned} \lambda_k &\geq (1 - 2\mu\epsilon s^{\frac{u-1}{2}})(2k + 1 + 2(\kappa + u))s \\ &\quad + \mu^2 D s^u (k + 1)^{-u} - 2\mu\tilde{C}s^{\frac{u+1}{2}} \pm (1 + 2(\kappa + u))s, \end{aligned} \quad (2.2.19)$$

$$\begin{aligned} \lambda_k &\leq (2k + 2 + (1 \mp 1)(2\kappa + u))s \\ &\quad + (2k + 1 + 2(\kappa + u))\epsilon(\mu^2 s^u + 4\mu u s^{\frac{u+1}{2}}) \\ &\quad + \mu^2 C s^u + 4\mu u E s^{\frac{u+1}{2}}. \end{aligned} \quad (2.2.20)$$

- $\mathcal{W}_{1,1}$  and  $\mathcal{W}_{2,2}$  also have a discrete spectrum, which has the lower bound given by (1.10.10) and Corollary 4.7.5-(v). We omit its explicit expression because it will not be used. The lower estimate of Corollary 4.7.5-(iii) may not be possible for  $\mathcal{W}_{1,1}$  and  $\mathcal{W}_{2,2}$  in general. In fact, according to Remark 1.10.4-(iv), the existence of  $\tilde{u}$  for  $\mathcal{W}_{1,1}$  (respectively,  $\mathcal{W}_{2,2}$ ) is characterized by the additional condition  $2\kappa > u$  (respectively,  $2\kappa < -3u$ ), which is an additional restriction.

Table 2.5 contains the information about the sign of the eigenvalues of  $\mathcal{P}_i$ ,  $\mathcal{Q}_j$  and  $\mathcal{W}_{i,j}$  given by the above spectral estimates.

|                     |                               | Sign of eigenvalues   |
|---------------------|-------------------------------|---|
| $\mathcal{P}_1$     |                               | $+ \quad \forall k \in 2\mathbb{N}$   |
| $\mathcal{P}_2^+$   | $\kappa > \frac{1}{2} - u$    | ? if $k < 2(\kappa + u) - 1$ even<br>$+ \quad$ if $k \geq 2(\kappa + u) - 1$ even |
|                     | $\kappa \leq \frac{1}{2} - u$ | $+ \quad \forall k \in 2\mathbb{N}$   |
| $\mathcal{P}_2^-$   |                               | $+ \quad \forall k \in 2\mathbb{N}$   |
| $\mathcal{Q}_1^+$   |                               | $+ \quad \forall k \in 2\mathbb{N} + 1$   |
| $\mathcal{Q}_1^-$   | $\kappa \geq -\frac{1}{2}$    | $+ \quad \forall k \in 2\mathbb{N} + 1$   |
|                     | $\kappa < -\frac{1}{2}$       | ? if $k < -2\kappa$ odd<br>$+ \quad$ if $k \geq -2\kappa$ odd                     |
| $\mathcal{Q}_2$     |                               | $+ \quad \forall k \in 2\mathbb{N} + 1$   |
| $\mathcal{W}_{i,j}$ |                               | $+ \quad$ if $k \gg 0$  |

Table 2.5: Sign of the eigenvalues of  $\mathcal{P}_i$ ,  $\mathcal{Q}_i$  and  $\mathcal{W}_{i,j}$ .

### Laplacians of the maximum/minimum i.b.c.

**Proposition 2.2.4.** *Tables 2.6, 2.7 and 2.8 describe  $\Delta_{\max/\min}$  for the stated values of  $\kappa$ .*

*Proof.* The operators  $d_{0,2}$ ,  $\delta_{0,2}$ ,  $d_{1,1}$  and  $\delta_{1,1}$  are of the same type as  $d$  and  $\delta$  in Section 2.2.1. Then, applying Proposition 2.2.1 and Remark 2.2.2-(ii), we obtain the inclusions

$$D(d_{0,2,\max}) \supset \begin{cases} \mathcal{F}_1^0 & \text{if } \kappa > -\frac{1}{2} - u \\ \mathcal{F}_2^0 & \text{if } \kappa \leq -\frac{1}{2} - u, \end{cases} \quad (2.2.21)$$

$$D(d_{0,2,\min}) \supset \begin{cases} \mathcal{F}_1^0 & \text{if } \kappa \geq \frac{1}{2} - u \\ \mathcal{F}_2^0 & \text{if } \kappa < \frac{1}{2} - u, \end{cases} \quad (2.2.22)$$

|   | $\Delta_{\max,0}$ |                               | $\Delta_{\min,0}$ |
|---|-------------------|-------------------------------|-------------------|
| $\kappa > -\frac{1}{2}$                       | $\mathcal{P}_1$   | $\kappa \geq \frac{1}{2} - u$ | $\mathcal{P}_1$   |
| $-\frac{1}{2} - u < \kappa \leq -\frac{1}{2}$ | ?                 | $\kappa < \frac{1}{2} - u$    | $\mathcal{P}_2$   |
| $\kappa \leq -\frac{1}{2} - u$                | $\mathcal{P}_2$   |                               |                   |

 Table 2.6: Description of  $\Delta_{\max/\min,0}$ .

|                            | $\Delta_{\max,2}$ |   | $\Delta_{\min,2}$ |
|----------------------------|-------------------|---|-------------------|
| $\kappa > -\frac{1}{2}$    | $\mathcal{Q}_1$   | $\kappa \geq \frac{1}{2}$                   | $\mathcal{Q}_1$   |
| $\kappa \leq -\frac{1}{2}$ | $\mathcal{Q}_2$   | $\frac{1}{2} - u \leq \kappa < \frac{1}{2}$ | ?                 |
|                            |                   | $\kappa < \frac{1}{2} - u$                  | $\mathcal{Q}_2$   |

 Table 2.7: Description of  $\Delta_{\max/\min,2}$ .

$$D(\delta_{0,2,\max}) \supset \begin{cases} \mathcal{F}_1^{1,2} & \text{if } \kappa \geq \frac{1}{2} - u \\ \mathcal{F}_2^{1,2} & \text{if } \kappa < \frac{1}{2} - u, \end{cases} \quad (2.2.23)$$

$$D(\delta_{0,2,\min}) \supset \begin{cases} \mathcal{F}_1^{1,2} & \text{if } \kappa > -\frac{1}{2} - u \\ \mathcal{F}_2^{1,2} & \text{if } \kappa \leq -\frac{1}{2} - u, \end{cases} \quad (2.2.24)$$

$$D(d_{1,1,\max}) \supset \begin{cases} \mathcal{F}_1^{1,1} & \text{if } \kappa > -\frac{1}{2} \\ \mathcal{F}_2^{1,1} & \text{if } \kappa \leq -\frac{1}{2}, \end{cases} \quad (2.2.25)$$

$$D(d_{1,1,\min}) \supset \begin{cases} \mathcal{F}_1^{1,1} & \text{if } \kappa \geq \frac{1}{2} \\ \mathcal{F}_2^{1,1} & \text{if } \kappa < \frac{1}{2}, \end{cases} \quad (2.2.26)$$

$$D(\delta_{1,1,\max}) \supset \begin{cases} \mathcal{F}_1^2 & \text{if } \kappa \geq \frac{1}{2} \\ \mathcal{F}_2^2 & \text{if } \kappa < \frac{1}{2}, \end{cases} \quad (2.2.27)$$

$$D(\delta_{1,1,\min}) \supset \begin{cases} \mathcal{F}_1^2 & \text{if } \kappa > -\frac{1}{2} \\ \mathcal{F}_2^2 & \text{if } \kappa \leq -\frac{1}{2}, \end{cases} \quad (2.2.28)$$

and the equalities

$$\begin{aligned} d_{0,2,\max} &= d_{0,2,\min}, & \delta_{0,2,\max} &= \delta_{0,2,\min} & \text{if } & |\kappa + u| \geq \frac{1}{2}, \\ d_{1,1,\max} &= d_{1,1,\min}, & \delta_{1,1,\max} &= \delta_{1,1,\min} & \text{if } & |\kappa| \geq \frac{1}{2}. \end{aligned}$$

|   |                     |  |                     |
|---|---------------------|--|---------------------|
|   | $\Delta_{\max,1}$   |  | $\Delta_{\min,1}$   |
| $\kappa > u - \frac{1}{2}$                    | $\mathcal{W}_{1,1}$ | $\kappa \geq \frac{1}{2}$                        | $\mathcal{W}_{1,1}$ |
| $-\frac{1}{2} < \kappa \leq u - \frac{1}{2}$  | ?                   | $\frac{1}{2} - u \leq \kappa < \frac{1}{2}$      | $\mathcal{W}_{2,1}$ |
| $-\frac{1}{2} - u < \kappa \leq -\frac{1}{2}$ | $\mathcal{W}_{2,1}$ | $\frac{1}{2} - 2u \leq \kappa < \frac{1}{2} - u$ | ?                   |
| $\kappa \leq -\frac{1}{2} - u$                | $\mathcal{W}_{2,2}$ | $\kappa < \frac{1}{2} - 2u$                      | $\mathcal{W}_{2,2}$ |

Table 2.8: Description of  $\Delta_{\max/\min,1}$ .

On the other hand, since  $d_{0,1}$ ,  $\delta_{0,1}$ ,  $d_{1,2}$  and  $\delta_{1,2}$  are multiplication operators, we have

$$\begin{aligned} d_{0,1,\max} &= d_{0,1,\min}, & \delta_{0,1,\max} &= \delta_{0,1,\min}, \\ d_{1,2,\max} &= d_{1,2,\min}, & \delta_{1,2,\max} &= \delta_{1,2,\min}. \end{aligned}$$

These are maximal multiplication operators [41, Examples III-2.2 and V-3.22]. They satisfy the following:

$$D(d_{0,1,\max/\min}) \supset \begin{cases} \mathcal{F}_1^0 & \text{if } \kappa > -\frac{1}{2} \\ \mathcal{F}_2^0 & \text{if } \kappa < \frac{3}{2} - 2u, \end{cases} \quad (2.2.29)$$

$$D(\delta_{0,1,\max/\min}) \supset \begin{cases} \mathcal{F}_1^{1,1} & \text{if } \kappa > u - \frac{1}{2} \\ \mathcal{F}_2^{1,1} & \text{if } \kappa < \frac{3}{2} - u, \end{cases} \quad (2.2.30)$$

$$D(d_{1,2,\max/\min}) \supset \begin{cases} \mathcal{F}_1^{1,2} & \text{if } \kappa > -\frac{3}{2} \\ \mathcal{F}_2^{1,2} & \text{if } \kappa < \frac{1}{2} - 2u, \end{cases} \quad (2.2.31)$$

$$D(\delta_{1,2,\max/\min}) \supset \begin{cases} \mathcal{F}_1^2 & \text{if } \kappa > u - \frac{3}{2} \\ \mathcal{F}_2^2 & \text{if } \kappa < \frac{1}{2} - u. \end{cases} \quad (2.2.32)$$

By Remark 2.2.2-(i), we also get

$$D(d_{\min,0}) = D(d_{0,1,\min}) \cap D(d_{0,2,\min}), \quad d_{\min,0} = \left( d_{0,1,\min} \Big|_{D(d_{\min,0})} \right), \quad (2.2.33)$$

$$D(\delta_{\min,1}) = D(\delta_{1,1,\min}) \cap D(\delta_{1,2,\min}), \quad \delta_{\min,1} = \left( \delta_{1,1,\min} \Big|_{D(\delta_{\min,1})} \right), \quad (2.2.34)$$

complementing Lemma 2.1.9 in this case.

From (2.2.21)–(2.2.34), Lemmas 2.1.9 and 2.1.10, and [72, Chapter XI-12, p. 338,

Eq. (1)], it follows that

$$\begin{aligned}
 D(\Delta_{\max,0}^{1/2}) &= D(d_{\max,0}) = D(d_{0,1,\max}) \cap D(d_{0,2,\max}) \supset \begin{cases} \mathcal{F}_1^0 & \text{if } \kappa > -\frac{1}{2} \\ \mathcal{F}_2^0 & \text{if } \kappa \leq -\frac{1}{2} - u, \end{cases} \\
 D(\Delta_{\min,0}^{1/2}) &= D(d_{\min,0}) = D(d_{0,1,\min}) \cap D(d_{0,2,\min}) \supset \begin{cases} \mathcal{F}_1^0 & \text{if } \kappa \geq \frac{1}{2} - u \\ \mathcal{F}_2^0 & \text{if } \kappa < \frac{1}{2} - u, \end{cases} \\
 D(\Delta_{\max,2}^{1/2}) &= D(\delta_{\min,1}) = D(\delta_{1,1,\min}) \cap D(\delta_{1,2,\min}) \supset \begin{cases} \mathcal{F}_1^2 & \text{if } \kappa > -\frac{1}{2} \\ \mathcal{F}_2^2 & \text{if } \kappa \leq -\frac{1}{2}, \end{cases} \\
 D(\Delta_{\min,2}^{1/2}) &= D(\delta_{\max,1}) = D(\delta_{1,1,\max}) \cap D(\delta_{1,2,\max}) \supset \begin{cases} \mathcal{F}_1^2 & \text{if } \kappa \geq \frac{1}{2} \\ \mathcal{F}_2^2 & \text{if } \kappa < \frac{1}{2} - u, \end{cases}
 \end{aligned}$$

$$\begin{aligned}
 D(\Delta_{\max,1}^{1/2}) &= D(\delta_{\min,0} + d_{\max,1}) = D(\delta_{\min,0}) \cap D(d_{\max,1}) \\
 &\supset (D(\delta_{0,1,\min}) \oplus D(\delta_{0,2,\min})) \cap (D(d_{1,1,\max}) \oplus D(d_{1,2,\max})) \\
 &\supset \begin{cases} \mathcal{F}_{1,1}^1 & \text{if } \kappa > u - \frac{1}{2} \\ \mathcal{F}_{2,1}^1 & \text{if } -\frac{1}{2} - u < \kappa \leq -\frac{1}{2} \\ \mathcal{F}_{2,2}^1 & \text{if } \kappa \leq -\frac{1}{2} - u, \end{cases} \\
 D(\Delta_{\min,1}^{1/2}) &= D(\delta_{\max,0} + d_{\min,1}) = D(\delta_{\max,0}) \cap D(d_{\min,1}) \\
 &\supset (D(\delta_{0,1,\max}) \oplus D(\delta_{0,2,\max})) \cap (D(d_{1,1,\min}) \oplus D(d_{1,2,\min})) \\
 &\supset \begin{cases} \mathcal{F}_{1,1}^1 & \text{if } \kappa \geq \frac{1}{2} \\ \mathcal{F}_{2,1}^1 & \text{if } \frac{1}{2} - u \leq \kappa < \frac{1}{2} \\ \mathcal{F}_{2,2}^1 & \text{if } \kappa < \frac{1}{2} - 2u. \end{cases}
 \end{aligned}$$

Since  $\mathcal{F}_i^0$ ,  $\mathcal{F}_j^2$  and  $\mathcal{F}_{i,j}^1$  are cores of  $\mathcal{P}_i^{1/2}$ ,  $\mathcal{Q}_j^{1/2}$  and  $\mathcal{W}_{i,j}^{1/2}$ , respectively, and taking into account Table 2.4, it follows that

$$\begin{aligned}
 \Delta_{\max,0}^{1/2} &\supset \begin{cases} \mathcal{P}_1^{1/2} & \text{if } \kappa > -\frac{1}{2} \\ \mathcal{P}_2^{1/2} & \text{if } \kappa \leq -\frac{1}{2} - u, \end{cases} & \Delta_{\min,0}^{1/2} &\supset \begin{cases} \mathcal{P}_1^{1/2} & \text{if } \kappa \geq \frac{1}{2} - u \\ \mathcal{P}_2^{1/2} & \text{if } \kappa < \frac{1}{2} - u, \end{cases} \\
 \Delta_{\max,2}^{1/2} &\supset \begin{cases} \mathcal{Q}_1^{1/2} & \text{if } \kappa > -\frac{1}{2} \\ \mathcal{Q}_2^{1/2} & \text{if } \kappa \leq -\frac{1}{2}, \end{cases} & \Delta_{\min,2}^{1/2} &\supset \begin{cases} \mathcal{Q}_1^{1/2} & \text{if } \kappa \geq \frac{1}{2} \\ \mathcal{Q}_2^{1/2} & \text{if } \kappa < \frac{1}{2} - u, \end{cases}
 \end{aligned}$$

$$\Delta_{\max,1}^{1/2} \supset \begin{cases} \mathcal{W}_{1,1}^{1/2} & \text{if } \kappa > u - \frac{1}{2} \\ \mathcal{W}_{2,1}^{1/2} & \text{if } -\frac{1}{2} - u < \kappa \leq -\frac{1}{2} \\ \mathcal{W}_{2,2}^{1/2} & \text{if } \kappa \leq -\frac{1}{2} - u, \end{cases}$$

$$\Delta_{\min,1}^{1/2} \supset \begin{cases} \mathcal{W}_{1,1}^{1/2} & \text{if } \kappa \geq \frac{1}{2} \\ \mathcal{W}_{2,1}^{1/2} & \text{if } \frac{1}{2} - u \leq \kappa < \frac{1}{2} \\ \mathcal{W}_{2,2}^{1/2} & \text{if } \kappa < \frac{1}{2} - 2u. \end{cases}$$

But these inclusions are equalities because they involve self-adjoint operators.  $\square$

**Proposition 2.2.5.** *We have  $\ker \Delta_{\max/\min} = 0$ .*

*Proof.* We have  $\ker \Delta_{\max/\min, \text{ev}} = 0$  because  $\ker d_{\max/\min,0} = 0$  and  $\ker \delta_{\max/\min,1} = 0$  by Lemma 2.1.9, (2.2.33) and (2.2.34), since  $d_{0,1,\max/\min}$  and  $\delta_{1,2,\max/\min}$  are maximal multiplication operators in  $L_+^2$  by continuous non-vanishing functions.<sup>4</sup>

Since  $\sigma(\Delta_{\max/\min, \text{ev}})$  is bounded away from 0, we get  $\text{R}(\Delta_{\max/\min,0}) = L_+^2 = \text{R}(\Delta_{\max/\min,2})$  by the spectral theorem. The maximal multiplication operator by  $\rho^{\pm u}$  in  $L_+^2$  will be also denoted by  $\rho^{\pm u}$ . Let  $\phi \in \text{D}(\Delta_{\max/\min,0})$  such that  $\Delta_{\max/\min,0}\phi \in \text{D}(\rho^u)$ . By (2.2.7),

$$\begin{aligned} \psi &:= \frac{1}{\mu} \rho^u d_{0,2,\max/\min} \phi \in \text{D}(\delta_{0,2,\max/\min} \rho^{-u}) \cap \text{D}(\rho^u \delta_{0,2,\max/\min} \rho^{-u}) \\ &= \text{D}(\rho^{-u} \delta_{1,1,\max/\min}) \cap \text{D}(\delta_{1,1,\max/\min}). \end{aligned}$$

Then  $\psi \in \text{D}(\delta_{\max/\min,1})$  by (2.2.34) since  $\rho^{-u}\psi \in L_+^2$  and  $\delta_{1,2,\max/\min}$  is the maximal multiplication operator by  $-\mu\rho^{-u}$ . In the following, for the sake of simplicity, the notation  $d_{0,2}$ ,  $\delta_{1,1}$ ,  $\delta_{0,2}$  and  $\Delta_0$  is used for  $d_{0,2,\max/\min}$ ,  $\delta_{1,1,\max/\min}$ ,  $\delta_{0,2,\max/\min}$  and  $\Delta_{\max/\min,0}$ , respectively. It also follows from (2.2.7) that

$$\begin{aligned} d_{\max/\min,0}(\phi) + \delta_{\max/\min,1}(\psi) &= \begin{pmatrix} \mu\rho^{-u}\phi + \delta_{1,1}\psi \\ d_{0,2}\phi - \mu\rho^{-u}\psi \end{pmatrix} \\ &= \begin{pmatrix} \mu\rho^{-u}\phi + \frac{1}{\mu}\delta_{1,1}\rho^u d_{0,2}\phi \\ 0 \end{pmatrix} = \begin{pmatrix} \mu\rho^{-u}\phi + \frac{1}{\mu}\rho^u \delta_{0,2} d_{0,2}\phi \\ 0 \end{pmatrix} = \begin{pmatrix} \frac{1}{\mu}\rho^u \Delta_0 \phi \\ 0 \end{pmatrix}. \end{aligned}$$

Since  $\text{R}(\Delta_{\max/\min,0}) = L_+^2$ , we get

$$\text{R}(\rho^u) \oplus 0 \subset \text{R}(d_{\max/\min,0}) + \text{R}(\delta_{\max/\min,1}).$$

With an analogous argument, using Lemma 2.1.9 instead of (2.2.34), we get

$$0 \oplus \text{R}(\rho^u) \subset \text{R}(d_{\max/\min,0}) + \text{R}(\delta_{\max/\min,1}).$$

---

<sup>4</sup>We may also use Table 2.5 and Proposition 2.2.4 for some values of  $\kappa$  (Tables 2.6 and 2.7).

Therefore

$$R(\rho^u) \oplus R(\rho^u) \subset R(d_{\max/\min,0}) + R(\delta_{\max/\min,1}),$$

obtaining that  $R(d_{\max/\min,0}) + R(\delta_{\max/\min,1})$  is dense in  $L_+^2 \oplus L_+^2$  because  $R(\rho^u)$  is dense in  $L_+^2$ . Thus  $\ker \Delta_{\max/\min,1} = 0$  [15, Lemma 2.1].  $\square$

**Corollary 2.2.6.**  $\Delta_{\max/\min, \text{ev}}$  and  $\Delta_{\max/\min,1}$  have the same eigenvalues, with the same multiplicity.

*Proof.* This is a direct consequence of Proposition 2.2.5 and Lemma 2.1.8.  $\square$

*Remark 2.2.7.* Some general properties of this complex of length two hold for all  $u > 0$ , like (2.2.21)–(2.2.34), Proposition 2.2.5 and Corollary 2.2.6. But the main results require  $0 < u < 1$ .

Concerning the spectrum, the following corollary fills the gaps in Tables 2.6–2.8.

**Corollary 2.2.8.** Tables 2.9 and 2.10 describe the spectra of  $\Delta_{\max/\min, \text{ev}}$  and  $\Delta_{\max/\min,1}$  in terms of the spectra of  $\mathcal{P}_i$ ,  $\mathcal{Q}_j$  and  $\mathcal{W}_{i,j}$  for the stated values of  $\kappa$ .

|   | $\sigma(\Delta_{\max, \text{ev}})$           |   | $\sigma(\Delta_{\min, \text{ev}})$           |
|---|--|---|--|
| $\kappa > -\frac{1}{2}$                       | $\sigma(\mathcal{P}_1 \oplus \mathcal{Q}_1)$ | $\kappa \geq \frac{1}{2}$                   | $\sigma(\mathcal{P}_1 \oplus \mathcal{Q}_1)$ |
| $-\frac{1}{2} - u < \kappa \leq -\frac{1}{2}$ | $\sigma(\mathcal{W}_{2,1})$                  | $\frac{1}{2} - u \leq \kappa < \frac{1}{2}$ | $\sigma(\mathcal{W}_{2,1})$                  |
| $\kappa \leq -\frac{1}{2} - u$                | $\sigma(\mathcal{P}_2 \oplus \mathcal{Q}_2)$ | $\kappa < \frac{1}{2} - u$                  | $\sigma(\mathcal{P}_2 \oplus \mathcal{Q}_2)$ |

Table 2.9: Spectrum of  $\Delta_{\max/\min, \text{ev}}$ .

|   | $\sigma(\Delta_{\max,1})$                    |  | $\sigma(\Delta_{\min,1})$                    |
|---|--|--|--|
| $\kappa > u - \frac{1}{2}$                    | $\sigma(\mathcal{W}_{1,1})$                  | $\kappa \geq \frac{1}{2}$                        | $\sigma(\mathcal{W}_{1,1})$                  |
| $-\frac{1}{2} < \kappa \leq u - \frac{1}{2}$  | $\sigma(\mathcal{P}_1 \oplus \mathcal{Q}_1)$ | $\frac{1}{2} - u \leq \kappa < \frac{1}{2}$      | $\sigma(\mathcal{W}_{2,1})$                  |
| $-\frac{1}{2} - u < \kappa \leq -\frac{1}{2}$ | $\sigma(\mathcal{W}_{2,1})$                  | $\frac{1}{2} - 2u \leq \kappa < \frac{1}{2} - u$ | $\sigma(\mathcal{P}_2 \oplus \mathcal{Q}_2)$ |
| $\kappa \leq -\frac{1}{2} - u$                | $\sigma(\mathcal{W}_{2,2})$                  | $\kappa < \frac{1}{2} - 2u$                      | $\sigma(\mathcal{W}_{2,2})$                  |

Table 2.10: Spectrum of  $\Delta_{\max/\min,1}$ .

*Proof.* This is a direct consequence of Proposition 2.2.4 and Corollary 2.2.6.  $\square$

### 2.2.3 The wave operator

For the Hermitian bundle versions of  $E$  and  $F$ , consider the wave operator on  $L^2(E)$  and  $L^2(F)$ , which is given by  $\exp(itD_{\max/\min})$  (with  $i = \sqrt{-1}$ ), and it is bounded.

**Proposition 2.2.9.** *For  $\phi$  in  $L^2(E)$  or  $L^2(F)$ , let  $\phi_t = \exp(itD_{\max/\min})\phi$ . If  $\text{supp } \phi \subset (0, a]$  for some  $a > 0$ , then  $\text{supp } \phi_t \subset (0, a + |t|]$  for all  $t \in \mathbb{R}$ .*

*Proof.* The case of  $E$  is given by [5, Proposition 8.7-(ii)]. Then consider the case of  $F$ , where the proof must be slightly changed because the needed description of  $D^\infty(\Delta_{\max/\min})$  is not available. Since  $\exp(itD_{\max/\min})$  is bounded, we can assume that  $\phi \in D^\infty(\Delta_{\max/\min})$ . Write  $\phi_t = \phi_{t,0} + \phi_{t,1} + \phi_{t,2}$  with  $\phi_{t,r} \in C^\infty(F_r) \equiv C_+^\infty$  ( $r = 0, 2$ ), and  $\phi_{t,1} \equiv \begin{pmatrix} \phi_{t,1,1} \\ \phi_{t,1,2} \end{pmatrix} \in C^\infty(F_1) \equiv C_+^\infty \oplus C_+^\infty$ . Suppose that  $t \geq 0$ , the other case being analogous. For any  $c > a$ ,

$$\begin{aligned} \frac{d}{dt} \int_{a+t}^c |\phi_t(\rho)|^2 d\rho &= \int_{a+t}^c ((iD\phi_t, \phi_t) + (\phi_t, iD\phi_t))(\rho) d\rho - |\phi_t(a+t)|^2 \\ &= i \int_{a+t}^c ((D\phi_t, \phi_t) - (\phi_t, D\phi_t))(\rho) d\rho - |\phi_t(a+t)|^2. \end{aligned}$$

Now,  $d_{0,1} \equiv \delta_{0,1}$  and  $d_{1,2} \equiv \delta_{1,2}$  are multiplication operators by real valued functions. Moreover  $d_{0,2}$  and  $\delta_{0,2}$  are equal to  $\frac{d}{d\rho}$  and  $-\frac{d}{d\rho}$ , respectively, up to the sum of multiplication operators by the same real valued functions, and the same is true for  $d_{1,1}$  and  $\delta_{1,1}$ . Thus

$$\begin{aligned} (D\phi_t, \phi_t) - (\phi_t, D\phi_t) &= (\delta_{0,1}\phi_{t,1,1} + \delta_{0,2}\phi_{t,1,2}, \phi_{t,0}) + (d_{1,1}\phi_{t,1,1} + d_{1,2}\phi_{t,1,2}, \phi_{t,2}) \\ &\quad + (d_{0,1}\phi_{t,0} + \delta_{1,1}\phi_{t,2}, \phi_{t,1,1}) + (d_{0,2}\phi_{t,0} + \delta_{1,2}\phi_{t,2}, \phi_{t,1,2}) \\ &\quad - (\phi_{t,0}, \delta_{0,1}\phi_{t,1,1} + \delta_{0,2}\phi_{t,1,2}) - (\phi_{t,2}, d_{1,1}\phi_{t,1,1} + d_{1,2}\phi_{t,1,2}) \\ &\quad - (\phi_{t,1,1}, d_{0,1}\phi_{t,0} + \delta_{1,1}\phi_{t,2}) - (\phi_{t,1,2}, d_{0,2}\phi_{t,0} + \delta_{1,2}\phi_{t,2}) \\ &= -\phi'_{t,1,2}\overline{\phi_{t,0}} + \phi'_{t,1,1}\overline{\phi_{t,2}} - \phi'_{t,2}\overline{\phi_{t,1,1}} + \phi'_{t,0}\overline{\phi_{t,1,2}} \\ &\quad + \phi_{t,0}\overline{\phi'_{t,1,2}} - \phi_{t,2}\overline{\phi'_{t,1,1}} + \phi_{t,1,1}\overline{\phi'_{t,2}} - \phi_{t,1,2}\overline{\phi'_{t,0}} \\ &= 2i \Im(\phi_{t,0}\overline{\phi'_{t,1,2}} + \phi'_{t,1,1}\overline{\phi_{t,2}} + \phi_{t,1,1}\overline{\phi'_{t,2}} + \phi'_{t,0}\overline{\phi_{t,1,2}}) \\ &= 2i \Im(\phi_{t,1,1}\overline{\phi_{t,2}} + \phi_{t,0}\overline{\phi_{t,1,2}})'. \end{aligned}$$

Therefore

$$i \int_{a+t}^c ((D\phi_t, \phi_t) - (\phi_t, D\phi_t))(\rho) d\rho \in \mathbb{R},$$

and

$$\begin{aligned}
 & \left| \int_{a+t}^c ((D\phi_t, \phi_t) - (\phi_t, D\phi_t))(\rho) d\rho \right| \\
 & \leq 2|(\phi_{t,1,1}\overline{\phi_{t,2}} + \phi_{t,0}\overline{\phi_{t,1,2}})(c) - (\phi_{t,1,1}\overline{\phi_{t,2}} + \phi_{t,0}\overline{\phi_{t,1,2}})(a+t)| \\
 & \leq |\phi_{t,1,1}(c)|^2 + |\phi_{t,2}(c)|^2 + |\phi_{t,1,2}(c)|^2 + |\phi_{t,0}(c)|^2 \\
 & \quad + |\phi_{t,1,1}(a+t)|^2 + |\phi_{t,2}(a+t)|^2 + |\phi_{t,1,2}(a+t)|^2 + |\phi_{t,0}(a+t)|^2 \\
 & = |\phi_t(c)|^2 + |\phi_t(a+t)|^2.
 \end{aligned}$$

Since  $t \mapsto \phi_t$  defines a differentiable map with values in  $L^2(F)$ , it follows that there is a sequence  $a < c_i \uparrow \infty$  such that  $\phi_t(c_i) \rightarrow 0$ , and

$$\frac{d}{dt} \int_{a+t}^{\infty} |\phi_t(\rho)|^2 d\rho = \lim_i \frac{d}{dt} \int_{a+t}^{c_i} |\phi_t(\rho)|^2 d\rho \leq \lim_i |\phi_t(c_i)|^2 = 0.$$

So

$$\int_{a+t}^{\infty} |\phi_t(\rho)|^2 d\rho \leq \int_a^{\infty} |\phi_0(\rho)|^2 d\rho = \int_a^{\infty} |\phi(\rho)|^2 d\rho = 0. \quad \square$$

## 2.3 Witten's perturbation on a cone

For rel-Morse functions, the rel-local analysis of the Witten's perturbed Laplacian will be reduced to the case of the functions  $\pm \frac{1}{2}\rho^2$  on a stratum of a cone with a model adapted metric, where  $\rho$  denotes the radial function. This kind of rel-local analysis begins in this section.

### 2.3.1 Witten's perturbation

To begin with, recall the following generalities about the Witten's perturbation. Let  $M \equiv (M, g)$  be a Riemannian  $n$ -manifold. For all  $x \in M$  and  $\alpha \in T_x M^*$ , let

$$\alpha \lrcorner = (-1)^{nr+n+1} \star \alpha \wedge \star = -\iota_{\alpha^\sharp} \quad \text{on} \quad \bigwedge^r T_x M^*,$$

involving the Hodge star operator  $\star$  on  $\bigwedge T_x M^*$  defined by any choice of orientation of  $T_x M$ . For any  $f \in C^\infty(M)$ , E. Witten [70] has introduced the following perturbations of  $d$ ,  $\delta$ ,  $D$  and  $\Delta$ , depending on  $s \geq 0$ :

$$d_s = e^{-sf} d e^{sf} = d + s df \wedge, \tag{2.3.1}$$

$$\delta_s = e^{sf} \delta e^{-sf} = \delta - s df \lrcorner, \tag{2.3.2}$$

$$D_s = d_s + \delta_s = D + sR,$$

$$\Delta_s = D_s^2 = d_s \delta_s + \delta_s d_s = \Delta + s(RD + DR) + s^2 R^2, \tag{2.3.3}$$

where  $R = df \wedge - df \lrcorner$ . Notice that  $\delta_s = d_s^\dagger$ ; thus  $D_s$  and  $\Delta_s$  are formally self-adjoint. By analyzing the terms  $RD + DR$  and  $R^2$ , the expression (2.3.3) becomes

$$\Delta_s = \Delta + s \mathbf{Hess} f + s^2 |df|^2, \quad (2.3.4)$$

where  $\mathbf{Hess} f$  is an endomorphism defined by  $\mathbf{Hess} f$  [59, Lemma 9.17], satisfying  $|\mathbf{Hess} f| = |\mathbf{Hess} f|$  [5, Section 9].

### 2.3.2 De Rham operators on a cone

Let  $L$  be a non-empty compact stratification. Consider a stratum  $N$  of  $L$ , and the corresponding stratum  $M = N \times \mathbb{R}_+$  of  $c(L)$ . We use the notation  $\tilde{n} = \dim N$  and  $n = \dim M = \tilde{n} + 1$ . Let  $\pi : M \rightarrow N$  be the first factor projection, and  $\rho$  the radial function on  $c(L)$ . From  $\bigwedge^r TM^* = \bigwedge^r TN^* \boxtimes \bigwedge^r T\mathbb{R}_+^*$ , we get a canonical identity

$$\begin{aligned} \bigwedge^r TM^* &\equiv \pi^* \bigwedge^r TN^* \oplus d\rho \wedge \pi^* \bigwedge^{r-1} TN^* \\ &\equiv \pi^* \bigwedge^r TN^* \oplus \pi^* \bigwedge^{r-1} TN^* \end{aligned} \quad (2.3.5)$$

for every degree  $r$ . So

$$\Omega^r(M) \equiv C^\infty(\mathbb{R}_+, \Omega^r(N)) \oplus d\rho \wedge C^\infty(\mathbb{R}_+, \Omega^{r-1}(N)) \quad (2.3.6)$$

$$\equiv C^\infty(\mathbb{R}_+, \Omega^r(N)) \oplus C^\infty(\mathbb{R}_+, \Omega^{r-1}(N)). \quad (2.3.7)$$

Here, smooth functions  $\mathbb{R}_+ \rightarrow \Omega(N)$  are defined by considering  $\Omega(N)$  as Fréchet space with the weak  $C^\infty$  topology. In this section, all matrix expressions of vector bundle homomorphisms on  $\bigwedge^r TM^*$  or differential operators on  $\Omega^r(M)$  will be considered with respect to the decompositions (2.3.5) and (2.3.7).

Let  $d$  and  $\tilde{d}$  denote the exterior derivatives on  $\Omega(M)$  and  $\Omega(N)$ , respectively. We have [5, Lemma 10.1]

$$d \equiv \begin{pmatrix} \tilde{d} & 0 \\ \frac{d}{d\rho} & -\tilde{d} \end{pmatrix}. \quad (2.3.8)$$

Fix a general adapted metric  $\tilde{g}$  on  $N$ . For  $u > 0$ , the metric  $g = \rho^{2u} \tilde{g} + d\rho^2$  is a general adapted metric on  $M$ . The induced metrics on  $\bigwedge^r TM^*$  and  $\bigwedge^r TN^*$  are also denoted by  $g$  and  $\tilde{g}$ , respectively. Fix some degree  $r \in \{0, 1, \dots, n\}$ , and, to simplify the expressions, let

$$\kappa = (n - 2r - 1) \frac{u}{2}. \quad (2.3.9)$$

According to (2.3.5),

$$g \equiv \rho^{-2ru} \tilde{g} \oplus \rho^{-2(r-1)u} \tilde{g} \quad (2.3.10)$$

on  $\bigwedge^r TM^*$ . Choose an orientation on an open subset  $W \subset N$ , and let  $\tilde{\omega}$  denote the corresponding  $\tilde{g}$ -volume form on  $W$ . Consider the orientation on  $W \times \mathbb{R}_+ \subset M$  so that the corresponding  $g$ -volume form is

$$\omega = \rho^{(n-1)u} d\rho \wedge \tilde{\omega}. \quad (2.3.11)$$

The corresponding Hodge star operators on  $\bigwedge T(W \times \mathbb{R}_+)^*$  and  $\bigwedge TW^*$  will be denoted by  $\star$  and  $\tilde{\star}$ , respectively. Like in [5, Lemma 10.2], from (2.3.10) and (2.3.11), it follows that

$$\star \equiv \begin{pmatrix} 0 & \rho^{2(\kappa+u)} \tilde{\star} \\ (-1)^r \rho^{2\kappa} \tilde{\star} & 0 \end{pmatrix} \quad (2.3.12)$$

on  $\bigwedge^r T(W \times \mathbb{R}_+)^*$ . Let  $L^2\Omega^r(M) = L^2\Omega^r(M, g)$  and  $L^2\Omega^r(N) = L^2\Omega^r(N, \tilde{g})$ . From (2.3.10) and (2.3.11), we also get that (2.3.7) induces the identity of Hilbert spaces<sup>5</sup>

$$L^2\Omega^r(M) \equiv (L^2_{\kappa,+} \hat{\otimes} L^2\Omega^r(N)) \oplus (L^2_{\kappa+u,+} \hat{\otimes} L^2\Omega^{r-1}(N)). \quad (2.3.13)$$

Let  $\delta$  and  $\tilde{\delta}$  denote the exterior coderivatives on  $\Omega(M)$  and  $\Omega(N)$ , respectively. Like in [5, Lemma 10.3], using (2.3.8), (2.3.12) and (4.7.1), we get

$$\delta \equiv \begin{pmatrix} \rho^{-2u} \tilde{\delta} & -\frac{d}{d\rho} - 2(\kappa+u)\rho^{-1} \\ 0 & -\rho^{-2u} \tilde{\delta} \end{pmatrix} \quad (2.3.14)$$

on  $\Omega^r(M)$ . Let  $\Delta$  and  $\tilde{\Delta}$  denote the Laplacians on  $\Omega(M)$  and  $\Omega(N)$ , respectively. Like in [5, Corollary 10.4], from (2.3.8), (2.3.14) and (4.7.1), it follows that

$$\Delta \equiv \begin{pmatrix} P & -2u\rho^{-1} \tilde{\Delta} \\ -2u\rho^{-2u-1} \tilde{\delta} & Q \end{pmatrix} \quad (2.3.15)$$

on  $\Omega^r(M)$ , where

$$P = \rho^{-2u} \tilde{\Delta} - \frac{d^2}{d\rho^2} - 2\kappa\rho^{-1} \frac{d}{d\rho}, \quad (2.3.16)$$

$$Q = \rho^{-2u} \tilde{\Delta} - \frac{d^2}{d\rho^2} - 2(\kappa+u) \frac{d}{d\rho} \rho^{-1}. \quad (2.3.17)$$

<sup>5</sup>Recall that, for Hilbert spaces  $\mathfrak{H}'$  and  $\mathfrak{H}''$ , with scalar products  $\langle \cdot, \cdot \rangle'$  and  $\langle \cdot, \cdot \rangle''$ , the notation  $\mathfrak{H}' \hat{\otimes} \mathfrak{H}''$  is used for the Hilbert space tensor product. This is the Hilbert space completion of the algebraic tensor product  $\mathfrak{H}' \otimes \mathfrak{H}''$  with respect to the scalar product defined by  $\langle u' \otimes u'', v' \otimes v'' \rangle = \langle u', v' \rangle' \langle u'', v'' \rangle''$ .

### 2.3.3 Witten's perturbation on a cone

Let  $d_s, \delta_s, D_s$  and  $\Delta_s$  ( $s \geq 0$ ) denote the Witten's perturbations of  $d, \delta, D$  and  $\Delta$  induced by the function  $f = \pm \frac{1}{2}\rho^2$  on  $M$ . The more explicit notation  $d_s^\pm, \delta_s^\pm, D_s^\pm$  and  $\Delta_s^\pm$  may be used if needed. In this case,  $df = \pm \rho d\rho$ . According to (2.3.7),

$$\rho d\rho \wedge \equiv \begin{pmatrix} 0 & 0 \\ \rho & 0 \end{pmatrix}, \quad -\rho d\rho \lrcorner \equiv \begin{pmatrix} 0 & \rho \\ 0 & 0 \end{pmatrix}.$$

So, by (2.3.8), (2.3.14), (2.3.1) and (2.3.2),

$$d_s \equiv \begin{pmatrix} \tilde{d} & 0 \\ \frac{d}{d\rho} \pm s\rho & -\tilde{d} \end{pmatrix}, \tag{2.3.18}$$

$$\delta_s \equiv \begin{pmatrix} \rho^{-2u} \tilde{\delta} & -\frac{d}{d\rho} - 2(\kappa + u)\rho^{-1} \pm s\rho \\ 0 & -\rho^{-2u} \tilde{\delta} \end{pmatrix}, \tag{2.3.19}$$

on  $\Omega^r(M)$ . Now,

$$R = \pm \rho(d\rho \wedge - d\rho \lrcorner) \equiv \pm \begin{pmatrix} 0 & \rho \\ \rho & 0 \end{pmatrix},$$

and therefore

$$R^2 \equiv \begin{pmatrix} \rho^2 & 0 \\ 0 & \rho^2 \end{pmatrix} \equiv \rho^2. \tag{2.3.20}$$

Like in [5, Lemma 10.6], we get

$$RD + DR = \mp V \tag{2.3.21}$$

on  $\Omega^r(M)$ , where  $V$  is given by (2.2.8). As a consequence of (2.3.3), (2.3.15) and (2.3.21), we obtain

$$\Delta_s \equiv \begin{pmatrix} P_s & -2u\rho^{-1}\tilde{d} \\ -2u\rho^{-2u-1}\tilde{\delta} & Q_s \end{pmatrix} \tag{2.3.22}$$

on  $\Omega^r(M)$ , where

$$P_s = \rho^{-2u}\tilde{\Delta} + H - 2\kappa\rho^{-1} \frac{d}{d\rho} \mp s(1 + 2\kappa), \tag{2.3.23}$$

$$Q_s = \rho^{-2u}\tilde{\Delta} + H - 2(\kappa + u)\frac{d}{d\rho} \rho^{-1} \mp s(-1 + 2(\kappa + u)). \tag{2.3.24}$$

## 2.4 Splitting of the Witten's complex on a cone

### 2.4.1 Spectral decomposition on the link of the cone

Theorem 1.6.1 is proved by induction on the depth. Thus, with the notation of Section 2.3, suppose that  $\tilde{g}$  is good, and  $\tilde{\Delta}_{\max/\min}$  satisfies the statement of Theorem 1.6.1. Moreover suppose that  $g$  is also good; that is,  $u \leq 1$ .

Let  $\tilde{\mathcal{H}}_{\max/\min} = \ker \tilde{D}_{\max/\min} = \ker \tilde{\Delta}_{\max/\min}$ , which is a graded subspace of  $\Omega(N) \cap L^2\Omega(N)$ . For every degree  $r$ , let  $\tilde{R}_{\max/\min, r-1}, \tilde{R}_{\max/\min, r}^* \subset L^2\Omega^r(N)$  be the images of  $\tilde{d}_{\max/\min, r-1}$  and  $\tilde{\delta}_{\max/\min, r}$ , respectively, which are closed subspaces. By restriction,  $\tilde{\Delta}_{\max/\min}$  defines self-adjoint operators in  $\tilde{R}_{\max/\min, r-1}$  and  $\tilde{R}_{\max/\min, r-1}^*$ , with the same eigenvalues [5, Section 5.1]. For any eigenvalue  $\tilde{\lambda}$  of the restriction of  $\tilde{\Delta}_{\max/\min}$  to  $\tilde{R}_{\max/\min, r-1}$ , let  $\tilde{R}_{\max/\min, r-1, \tilde{\lambda}}$  and  $\tilde{R}_{\max/\min, r-1, \tilde{\lambda}}^*$  denote the corresponding  $\tilde{\lambda}$ -eigenspaces. We have<sup>6</sup>

$$L^2\Omega^r(N) = \tilde{\mathcal{H}}_{\max/\min}^r \oplus \widehat{\bigoplus_{\tilde{\lambda}, \tilde{\lambda}'}} \left( \tilde{R}_{\max/\min, r-1, \tilde{\lambda}} \oplus \tilde{R}_{\max/\min, r, \tilde{\lambda}'}^* \right), \quad (2.4.1)$$

where  $\tilde{\lambda}$  and  $\tilde{\lambda}'$  run in the spectrum of the restrictions of  $\tilde{\Delta}_{\max/\min}$  to  $\tilde{R}_{\max/\min, r-1}$  and  $\tilde{R}_{\max/\min, r}^*$ , respectively.

### 2.4.2 Subcomplexes of length one

Given  $0 \neq \gamma \in \tilde{\mathcal{H}}_{\max/\min}^r$ , consider the canonical identities

$$\begin{aligned} C_+^\infty &\equiv C_+^\infty \gamma \subset \Omega^r(M), \\ C_+^\infty &\equiv C_+^\infty d\rho \wedge \gamma \subset \Omega^{r+1}(M). \end{aligned} \quad (2.4.2)$$

The following result follows from (2.3.18) and (2.3.19).

**Lemma 2.4.1.** *For  $s \geq 0$ ,  $d_s$  and  $\delta_s$  define maps*

$$0 \begin{array}{c} \xleftarrow{d_{s, r-1}} \\ \xrightarrow{\delta_{s, r-1}} \end{array} C_+^\infty \gamma \begin{array}{c} \xleftarrow{d_{s, r}} \\ \xrightarrow{\delta_{s, r}} \end{array} C_+^\infty d\rho \wedge \gamma \begin{array}{c} \xleftarrow{d_{s, r+1}} \\ \xrightarrow{\delta_{s, r+1}} \end{array} 0.$$

<sup>6</sup>Consider a family of Hilbert spaces,  $\mathfrak{H}_a$  with scalar product  $\langle \cdot, \cdot \rangle_a$ . Recall that the Hilbert space direct sum,  $\widehat{\bigoplus}_a \mathfrak{H}_a$ , is the Hilbert space completion of the algebraic direct sum,  $\bigoplus_a \mathfrak{H}_a$ , with respect to the scalar product  $\langle (u^a), (v^a) \rangle = \sum_a \langle u^a, v^a \rangle_a$ . Thus  $\widehat{\bigoplus}_a \mathfrak{H}_a = \bigoplus_a \mathfrak{H}_a$  if and only if the family is finite.

Moreover, using (2.4.2),

$$\begin{aligned} d_{s,r} &= \frac{d}{d\rho} \pm s\rho, \\ \delta_{s,r} &= -\frac{d}{d\rho} - 2\kappa\rho^{-1} \pm s\rho. \end{aligned}$$

Let  $\mathcal{E}_{\gamma,0}$  denote the subcomplex of length one of  $(\Omega(M), d_s)$  defined by

$$\begin{aligned} \mathcal{E}_{\gamma,0}^r &= C_{+,0}^\infty \gamma \equiv C_{+,0}^\infty, \\ \mathcal{E}_{\gamma,0}^{r+1} &= C_{+,0}^\infty d\rho \wedge \gamma \equiv C_{+,0}^\infty. \end{aligned}$$

The closure of  $\mathcal{E}_{\gamma,0}$  in  $L^2\Omega(M)$  is denoted by  $L^2\mathcal{E}_\gamma$ . By (2.3.13),

$$\begin{aligned} L^2\mathcal{E}_\gamma^r &= L_{\kappa,+}^2 \gamma \equiv L_{\kappa,+}^2, \\ L^2\mathcal{E}_\gamma^{r+1} &= L_{\kappa,+}^2 d\rho \wedge \gamma \equiv L_{\kappa,+}^2. \end{aligned}$$

Assume now that  $s > 0$ . With the notation of Section 2.2.1, consider the real version of the elliptic complex  $(E, d)$  determined by  $s$  and  $\kappa$  (given by (2.3.9)). Using Lemma 2.4.1 and (4.7.1), like in [5, Proposition 12.3], we get the following.

**Proposition 2.4.2.** *The operator  $\rho^\kappa : L_{\kappa,+}^2 \rightarrow L_+^2$  defines a unitary isomorphism  $L^2\mathcal{E}_\gamma \rightarrow L^2(E)$ , which restricts to an isomorphism of complexes,  $(\mathcal{E}_{\gamma,0}, d_s) \rightarrow (C_0^\infty(E), d)$ , up to a shift of degree.*

By Proposition 2.4.2,  $(\mathcal{E}_{\gamma,0}, d_s)$  has a maximum/minimum Hilbert complex extension in  $L^2\mathcal{E}_\gamma$ . Let  $(D_\gamma, \mathbf{d}_{s,\gamma})$  be the maximum/minimum Hilbert complex extension of  $(\mathcal{E}_{\gamma,0}, d_s)$  if  $\gamma \in \mathcal{H}_{\max/\min}^r$ , and  $\Delta_{s,\gamma}$  the corresponding Laplacian. Let  $\mathcal{H}_{s,\gamma} = \mathcal{H}_{s,\gamma}^r \oplus \mathcal{H}_{s,\gamma}^{r+1} = \ker \Delta_{s,\gamma}$ , with the induced grading. The more explicit notation  $\mathbf{d}_{s,\gamma}^\pm$ ,  $\Delta_{s,\gamma}^\pm$  and  $\mathcal{H}_{s,\gamma}^\pm = \mathcal{H}_{s,\gamma}^{\pm,r} \oplus \mathcal{H}_{s,\gamma}^{\pm,r+1}$  may be also used.

**Corollary 2.4.3.** (i)  $\Delta_{s,\gamma}$  has a discrete spectrum.

(ii) The dimensions of  $\mathcal{H}_{s,\gamma}^{\pm,r}$  and  $\mathcal{H}_{s,\gamma}^{\pm,r+1}$  are given in Table 2.11.

(iii) If  $e_s \in \mathcal{H}_{s,\gamma}$  with norm one for every  $s$ , and  $h$  is a bounded measurable function on  $\mathbb{R}_+$  with  $h(\rho) \rightarrow 1$  as  $\rho \rightarrow 0$ , then  $\langle he_s, e_s \rangle \rightarrow 1$  as  $s \rightarrow \infty$ .

(iv) All nonzero eigenvalues of  $\Delta_{s,\gamma}$  are positive and in  $O(s)$  as  $s \rightarrow \infty$ .

*Proof.* This follows from Propositions 2.4.2 and 2.2.1, Corollary 4.7.8, Section 2.2.1, and the choice made to define  $\mathbf{d}_{s,\gamma}$ . □

|                            | $\gamma \in \tilde{\mathcal{H}}_{\max}^r$ |                                  |                                |                                  | $\gamma \in \tilde{\mathcal{H}}_{\min}^r$ |                                  |                                |                                  |
|----------------------------|---|----------------------------------|--------------------------------|----------------------------------|---|----------------------------------|--------------------------------|----------------------------------|
|                            | $\mathcal{H}_{s,\gamma}^{+,r}$            | $\mathcal{H}_{s,\gamma}^{+,r+1}$ | $\mathcal{H}_{s,\gamma}^{-,r}$ | $\mathcal{H}_{s,\gamma}^{-,r+1}$ | $\mathcal{H}_{s,\gamma}^{+,r}$            | $\mathcal{H}_{s,\gamma}^{+,r+1}$ | $\mathcal{H}_{s,\gamma}^{-,r}$ | $\mathcal{H}_{s,\gamma}^{-,r+1}$ |
| $\kappa \geq \frac{1}{2}$  | 1   | 0                                | 0                              | 0                                | 1   | 0                                | 0                              | 0                                |
| $ \kappa  < \frac{1}{2}$   |   |                                  |                                |                                  | 0   |                                  |                                | 1                                |
| $\kappa \leq -\frac{1}{2}$ | 0   |                                  | 1                              |                                  |   |                                  |                                |                                  |

 Table 2.11: Dimensions of  $\mathcal{H}_{s,\gamma}^{\pm,r}$  and  $\mathcal{H}_{s,\gamma}^{\pm,r+1}$ .

### 2.4.3 Subcomplexes of length two

Let  $\mu = \sqrt{\tilde{\lambda}}$  for an eigenvalue  $\tilde{\lambda}$  of the restriction of  $\tilde{\Delta}_{\max/\min}$  to  $\tilde{\mathcal{R}}_{\max/\min,r-1}$ . According to [5, Section 5.1], there are nonzero differential forms,

$$\begin{aligned}\alpha &\in \tilde{\mathcal{R}}_{\max/\min,r-1,\tilde{\lambda}} \subset \Omega^r(N), \\ \beta &\in \tilde{\mathcal{R}}_{\max/\min,r-1,\tilde{\lambda}}^* \subset \Omega^{r-1}(N),\end{aligned}$$

such that  $\tilde{d}\beta = \mu\alpha$  and  $\tilde{\delta}\alpha = \mu\beta$ . Consider the canonical identities

$$C_+^\infty \equiv C_+^\infty \beta \subset \Omega^{r-1}(M),$$

$$C_+^\infty \equiv C_+^\infty d\rho \wedge \alpha \subset \Omega^{r+1}(M), \quad (2.4.3)$$

$$C_+^\infty \oplus C_+^\infty \equiv C_+^\infty \alpha + C_+^\infty d\rho \wedge \beta \subset \Omega^r(M). \quad (2.4.4)$$

The following result follows from (2.3.18) and (2.3.19).

**Lemma 2.4.4.** For  $s \geq 0$ ,  $d_s$  and  $\delta_s$  define maps

$$\begin{array}{ccccc} 0 & \xrightleftharpoons[\delta_{s,r-2}]{d_{s,r-2}} & C_+^\infty \beta & \xrightleftharpoons[\delta_{s,r-1}]{d_{s,r-1}} & C_+^\infty \alpha + C_+^\infty d\rho \wedge \beta \\ & & & \xrightleftharpoons[\delta_{s,r}]{d_{s,r}} & C_+^\infty d\rho \wedge \alpha \xrightleftharpoons[\delta_{s,r+1}]{d_{s,r+1}} 0. \end{array}$$

Moreover, according to (2.4.3) and (2.4.4),

$$\begin{aligned} d_{s,r-1} &= \left( \begin{array}{c} \mu \\ \frac{d}{d\rho} \pm s\rho \end{array} \right), \\ \delta_{s,r-1} &= \left( \begin{array}{cc} \mu\rho^{-2u} & -\frac{d}{d\rho} - 2(\kappa + u)\rho^{-1} \pm s\rho \end{array} \right), \\ d_{s,r} &= \left( \begin{array}{cc} \frac{d}{d\rho} \pm s\rho & -\mu \end{array} \right), \\ \delta_{s,r} &= \left( \begin{array}{cc} -\frac{d}{d\rho} - 2\kappa\rho^{-1} \pm s\rho & \\ & -\mu\rho^{-2u} \end{array} \right). \end{aligned}$$

Let  $\mathcal{F}_{\alpha,\beta,0} = \mathcal{F}_{\alpha,\beta,0}^{r-1} \oplus \mathcal{F}_{\alpha,\beta,0}^r \oplus \mathcal{F}_{\alpha,\beta,0}^{r+1}$  denote the subcomplex of length two of  $(\Omega(M), d_s)$  defined by

$$\begin{aligned} \mathcal{F}_{\alpha,\beta,0}^{r-1} &= C_{+,0}^\infty \beta \equiv C_{+,0}^\infty, \\ \mathcal{F}_{\alpha,\beta,0}^{r+1} &= C_{+,0}^\infty d\rho \wedge \alpha \equiv C_{+,0}^\infty, \\ \mathcal{F}_{\alpha,\beta,0}^r &= C_{+,0}^\infty \alpha + C_{+,0}^\infty d\rho \wedge \beta \equiv C_{+,0}^\infty \oplus C_{+,0}^\infty. \end{aligned}$$

The closure of  $\mathcal{F}_{\alpha,\beta,0}$  in  $L^2\Omega(M)$  is denoted by  $L^2\mathcal{F}_{\alpha,\beta}$ . By (2.3.13),

$$\begin{aligned} L^2\mathcal{F}_{\alpha,\beta}^{r-1} &= L_{\kappa+u,+}^2 \beta \equiv L_{\kappa+u,+}^2, \\ L^2\mathcal{F}_{\alpha,\beta}^{r+1} &= L_{\kappa,+}^2 d\rho \wedge \alpha \equiv L_{\kappa,+}^2, \\ L^2\mathcal{F}_{\alpha,\beta}^r &= L_{\kappa,+}^2 \alpha + L_{\kappa+u,+}^2 d\rho \wedge \beta \equiv L_{\kappa,+}^2 \oplus L_{\kappa+u,+}^2. \end{aligned}$$

Assume now that  $s > 0$ . With the notation of Section 2.2.2, consider the real version of the elliptic complex  $(F, d)$  determined by  $s$  and  $\kappa$  (given by (2.3.9)). Using Lemma 2.4.4 and (4.7.1), we get the following (cf. [5, Proposition 12.9]).

**Proposition 2.4.5.** *If  $u < 1$ , then  $\rho^\kappa : L_{\kappa,+}^2 \rightarrow L_+^2$  and  $\rho^{\kappa+u} : L_{\kappa+u,+}^2 \rightarrow L_+^2$  define a unitary isomorphism  $L^2\mathcal{F}_{\alpha,\beta} \rightarrow L^2(F)$ , which restricts to an isomorphism of complexes,  $(\mathcal{F}_{\alpha,\beta,0}, d_s) \rightarrow (C_0^\infty(F), d)$ , up to a shift of degree.*

By Proposition 2.4.5,  $(\mathcal{F}_{\alpha,\beta,0}, d_s)$  has a maximum/minimum Hilbert complex extension in  $L^2\mathcal{F}_{\alpha,\beta}$ . Let  $(D_{\alpha,\beta}, \mathbf{d}_{s,\alpha,\beta})$  be the maximum/minimum Hilbert complex extension of  $(\mathcal{F}_{\alpha,\beta,0}, d_s)$  if  $\alpha \in \tilde{R}_{\max/\min, r-1, \tilde{\lambda}}$  and  $\beta \in \tilde{R}_{\max/\min, r-1, \tilde{\lambda}}^*$ . Let  $\Delta_{s,\alpha,\beta}$  denote the corresponding Laplacian. The more explicit notation  $\mathbf{d}_{s,\alpha,\beta}^\pm$  and  $\Delta_{s,\alpha,\beta}^\pm$  may be used.

**Corollary 2.4.6.** (i)  $\Delta_{s,\alpha,\beta}$  has a discrete spectrum.

(ii) The eigenvalues of  $\Delta_{s,\alpha,\beta}$  are positive and in  $O(s)$  as  $s \rightarrow \infty$ .

*Proof.* In the case  $u < 1$ , this follows from Proposition 2.4.5 and Corollary 2.2.8. In the case  $u = 1$ , this is the content of [5, Proposition 12.11].  $\square$

*Remark 2.4.7.* According to (2.3.21)–(2.3.24), we have

$$\begin{aligned} \Delta_s &\equiv H - 2\kappa\rho^{-1} \frac{d}{d\rho} \mp s(1 + 2\kappa) && \text{on } C_+^\infty \equiv C_+^\infty \gamma, \\ \Delta_s &\equiv H - 2\kappa \frac{d}{d\rho} \rho^{-1} \mp s(-1 + 2\kappa) && \text{on } C_+^\infty \equiv C_+^\infty d\rho \wedge \gamma, \\ \Delta_s &\equiv H - 2(\kappa + u)\rho^{-1} \frac{d}{d\rho} + \mu^2 \rho^{-2u} \mp s(1 + 2(\kappa + u)) && \text{on } C_+^\infty \equiv C_+^\infty \beta, \\ \Delta_s &\equiv H - 2\kappa \frac{d}{d\rho} \rho^{-1} + \mu^2 \rho^{-2u} \mp s(-1 + 2\kappa) && \text{on } C_+^\infty \equiv C_+^\infty d\rho \wedge \alpha, \end{aligned}$$

and

$$\Delta_s \equiv \begin{pmatrix} P_{\mu,s} & -2\mu u \rho^{-1} \\ -2\mu u \rho^{-2u-1} & Q_{\mu,s} \end{pmatrix}$$

on  $C_+^\infty \oplus C_+^\infty \equiv C_+^\infty \alpha + C_+^\infty d\rho \wedge \beta$ , where

$$\begin{aligned} P_{\mu,s} &= H - 2\kappa\rho^{-1} \frac{d}{d\rho} + \mu^2 \rho^{-2u} \mp s(1 + 2\kappa), \\ Q_{\mu,s} &= H - 2(\kappa + u) \frac{d}{d\rho} \rho^{-1} + \mu^2 \rho^{-2u} \mp s(-1 + 2(\kappa + u)). \end{aligned}$$

So the results of Section ?? could be applied to these expressions. We opted for analyzing first the complexes of Section 2.2 for the sake of simplicity because we have  $a = b = 0$ ,  $L_+^2$  is used instead of  $L_{\kappa,+}^2$  or  $L_{\kappa+u,+}^2$ , and Remark 2.2.2 is directly applied.

## 2.4.4 Splitting into subcomplexes

Let  $\mathcal{C}_{\max/\min,0}$  denote an orthonormal frame of  $\tilde{\mathcal{H}}_{\max/\min}$  consisting of homogeneous differential forms. For every positive eigenvalue  $\mu$  of  $\tilde{D}_{\max/\min}$ , let  $\mathcal{C}_{\max/\min,\mu}$  be an orthonormal frame of the  $\mu$ -eigenspace of  $\tilde{D}_{\max/\min}$  consisting of differential forms  $\alpha + \beta$  like in Section 2.4.3. Then let

$$\mathbf{d}_{s,\max/\min} = \bigoplus_{\gamma} \mathbf{d}_{s,\gamma} \oplus \widehat{\bigoplus_{\mu} \bigoplus_{\alpha+\beta} \mathbf{d}_{s,\alpha,\beta}},$$

where  $\gamma$  runs in  $\mathcal{C}_{\max/\min,0}$ ,  $\mu$  runs in the positive spectrum of  $\tilde{D}_{\max/\min}$ , and  $\alpha + \beta$  runs in  $\mathcal{C}_{\max/\min,\mu}$ . The notation  $\mathbf{d}_{s,\max/\min}^\pm$  may be also used when  $\mathbf{d}_{s,\gamma}^\pm$  and  $\mathbf{d}_{s,\alpha,\beta}^\pm$  are considered.

**Proposition 2.4.8.** *We have  $d_{s,\max/\min} = \mathbf{d}_{s,\max/\min}$ .*

*Proof.* This follows like [5, Proposition 12.12], using [5, Lemma 5.2], [15, Lemma 3.6 and (2.38b)], (2.3.6) and (2.4.1).  $\square$

Let  $\mathcal{H}_{s,\max/\min} = \bigoplus_r \mathcal{H}_{s,\max/\min}^r = \ker \Delta_{s,\max/\min}$ , with the induced grading. The superindex “ $\pm$ ” may be added to this notation to indicate that we are referring to  $\Delta_{s,\max/\min}^\pm$ .

**Corollary 2.4.9.** (i)  $\Delta_{s,\max/\min}$  has a discrete spectrum.

(ii) Table 2.12 describes the isomorphism class of  $\mathcal{H}_{s,\max/\min}^{\pm,*}$ .

(iii) If  $e_s \in \mathcal{H}_{s,\max/\min}$  has norm one for every  $s$ , and  $h$  is a bounded measurable function on  $\mathbb{R}_+$  with  $h(\rho) \rightarrow 1$  as  $\rho \rightarrow 0$ , then  $\langle h e_s, e_s \rangle \rightarrow 1$  as  $s \rightarrow \infty$ .

(iv) Let  $0 \leq \lambda_{s,\max/\min,0} \leq \lambda_{s,\max/\min,1} \leq \dots$  be the eigenvalues of  $\Delta_{s,\max/\min}$ , repeated according to their multiplicities. Given  $k \in \mathbb{N}$ , if  $\lambda_{s,\max/\min,k} > 0$  for some  $s$ , then  $\lambda_{s,\max/\min,k} > 0$  for all  $s$ , and  $\lambda_{s,\max/\min,k} \in O(s)$  as  $s \rightarrow \infty$ .

(v) There is some  $\theta > 0$  such that  $\liminf_k \lambda_{s,\max/\min,k} k^{-\theta} > 0$ .

|                            | $\mathcal{H}_{s,\max}^{+,r}$ | $\mathcal{H}_{s,\max}^{-,r+1}$ | $\mathcal{H}_{s,\min}^{+,r}$ | $\mathcal{H}_{s,\min}^{-,r+1}$ |
|----------------------------|------------------------------|--------------------------------|------------------------------|--------------------------------|
| $\kappa \geq \frac{1}{2}$  | $H_{\max}^r(N)$              | 0                              | $H_{\min}^r(N)$              | 0                              |
| $ \kappa  < \frac{1}{2}$   |                              |                                | 0                            | $H_{\min}^r(N)$                |
| $\kappa \leq -\frac{1}{2}$ | 0                            | $H_{\max}^r(N)$                |                              |                                |

Table 2.12: Spaces isomorphic to  $\mathcal{H}_{s,\max/\min}^{\pm,*}$ .

*Proof.* In the case  $u = 1$ , this result was already shown in [5, Corollary 12.13]. So we consider only the case  $0 < u < 1$ . For all  $\gamma, \mu$  and  $\alpha + \beta$  as above,  $\Delta_{s,\gamma}$  and  $\Delta_{s,\alpha,\beta}$  have a discrete spectrum by Corollaries 2.4.3-(i) and 2.4.6-(i). Moreover the union of their spectra has no accumulation points according to Section 2.2 and since  $\tilde{\Delta}_{\max/\min}$  is discrete. Then (i) follows by Proposition 2.4.8.

Now, properties (ii)–(iv) follow directly from Corollaries 2.4.3 and 2.4.6, and Proposition 2.4.8.

To prove (v), let  $0 \leq \tilde{\lambda}_{\max/\min,0} \leq \tilde{\lambda}_{\max/\min,1} \leq \dots$  denote the eigenvalues of  $\tilde{\Delta}_{\max/\min}$ , repeated according to their multiplicities. Since, by induction hypothesis,  $N$  satisfies Theorem 1.6.1-(ii) with  $\tilde{g}$ , there is some  $C_0, \theta_0 > 0$  such that

$$\tilde{\lambda}_{\max/\min,\ell} \geq C_0 \ell^{\theta_0} \tag{2.4.5}$$

for all  $\ell$  large enough. Consider the counting function

$$\mathfrak{N}_{s,\max/\min}^{\pm}(\lambda) = \# \left\{ k \in \mathbb{N} \mid \lambda_{s,\max/\min,k}^{\pm} < \lambda \right\} \quad (\lambda > 0).$$

From Proposition 2.2.5, Corollary 2.2.8, (2.2.3)–(2.2.6), (2.2.9), (2.2.11), (2.2.13), (2.2.15), (2.2.17), (2.2.19) and (2.4.5), and the choices made to define  $\mathbf{d}_{\gamma}$  and  $\mathbf{d}_{\alpha,\beta}$  (Sections 2.4.2 and 2.4.3), it follows that there are some  $C_1, C_2 > 0$  and  $C_3, C'_3 \in \mathbb{R}$  such that

$$\begin{aligned} \mathfrak{N}_{s,\max/\min}^{\pm}(\lambda) &\leq \# \left\{ (k, \ell) \in \mathbb{N}^2 \mid C_1 k + C_2 \tilde{\lambda}_{\max/\min,\ell} (k+1)^{-u} + C'_3 \leq \lambda \right\} \\ &\leq \# \left\{ (k, \ell) \in \mathbb{N}^2 \mid C_1 k + C_2 C_0 \ell^{\theta_0} (k+1)^{-u} + C_3 \leq \lambda \right\} \\ &\leq \# \left\{ (k, \ell) \in \mathbb{N}^2 \mid 0 \leq \frac{\lambda - C_3}{C_1}, \ell \leq \left( \frac{\lambda - C_3 - C_1 k}{C_2 C_0} \right)^{\frac{1}{\theta_0}} (k+1)^{\frac{u}{\theta_0}} \right\}. \end{aligned}$$

Consider the function

$$f : \left[ -1, a := \frac{\lambda - C_3}{C_1} \right] \rightarrow [0, \infty), \quad f(x) = \left( \frac{\lambda - C_3 - C_1 x}{C_2 C_0} \right)^{\frac{1}{\theta_0}} (x+1)^{\frac{u}{\theta_0}}.$$

Elementary calculus shows that  $f$  vanishes at  $x = -1, a$ , it reaches its maximum at

$$x = b := \frac{\lambda u - C_3 u - C_1}{C_1(1+u)},$$

and it is strictly increasing (respectively, decreasing) on  $[-1, b]$  (respectively,  $[b, a]$ ). It follows that<sup>7</sup>

$$\mathfrak{N}_{s,\max/\min}^{\pm}(\lambda) \leq \int_0^a f(x) dx + 2f(b) + a + 1.$$

But

$$f(b) = \left( \frac{\lambda - C_3 + C_1}{(1+u)C_2 C_0} \right)^{\frac{1}{\theta_0}} \left( \frac{u(\lambda - C_3 + C_1)}{(1+u)C_1} \right)^{\frac{u}{\theta_0}},$$

<sup>7</sup>A similar argument is made in the proof of [5, Corollary 12.13-(viii)]. In that case, the authors use a strictly decreasing function  $f : (-\infty, a] \rightarrow [0, \infty)$ . The resulting estimate should be

$$\mathfrak{N}_{s,\max/\min}^{\pm}(\lambda) \leq \int_0^a f(x) dx + f(0) + a + 1,$$

but the terms  $f(0) + a + 1$  were missing in that publication. This correction does not affect the final estimate of  $\mathfrak{N}_{s,\max/\min}^{\pm}(\lambda)$  obtained there.

and

$$\begin{aligned}
 \int_0^a f(x) dx &\leq \left( \int_0^{\frac{\lambda-C_3}{C_1}} \left( \frac{\lambda - C_3 - C_1 x}{C_2 C_0} \right)^{\frac{2}{\theta_0}} dx \right)^{\frac{1}{2}} \left( \int_0^{\frac{\lambda-C_3}{C_1}} (x+1)^{\frac{2u}{\theta_0}} dx \right)^{\frac{1}{2}} \\
 &\leq \left( \frac{\theta_0(\lambda - C_3)^{\frac{2}{\theta_0}+1}}{(2 + \theta_0)(C_2 C_0)^{\frac{2}{\theta_0}} C_1} \right)^{\frac{1}{2}} \left( \frac{\theta_0(\lambda - C_3 + C_1)^{\frac{2u}{\theta_0}+1}}{(2u + \theta_0) C_1^{\frac{2u}{\theta_0}+1}} \right)^{\frac{1}{2}} \\
 &= \frac{\theta_0(\lambda - C_3)^{\frac{1}{\theta_0}+\frac{1}{2}} (\lambda - C_3 + C_1)^{\frac{u}{\theta_0}+\frac{1}{2}}}{(2 + \theta_0)^{\frac{1}{2}} (2u + \theta_0)^{\frac{1}{2}} (C_2 C_0)^{\frac{1}{\theta_0}} C_1^{1+\frac{u}{\theta_0}}}.
 \end{aligned}$$

So  $\mathfrak{N}_{s,\max/\min}^\pm(\lambda) \leq C \lambda^{\frac{1+u}{\theta_0}+1}$  for some  $C > 0$  and all large enough  $\lambda$ , giving (v) with  $\theta = \left(\frac{1+u}{\theta_0} + 1\right)^{-1} > 0$ . □

Table 2.13 describes the above conditions on  $\kappa$  in terms of  $r$ .

|                            |                                       |
|----------------------------|---------------------------------------|
| $\kappa \geq \frac{1}{2}$  | $r \leq \frac{n-1}{2} - \frac{1}{2u}$ |
| $ \kappa  < \frac{1}{2}$   | $ r - \frac{n-1}{2}  < \frac{1}{2u}$  |
| $\kappa \leq -\frac{1}{2}$ | $r \geq \frac{n-1}{2} + \frac{1}{2u}$ |

Table 2.13: Correspondence between conditions on  $\kappa$  and  $r$ .

## 2.5 Relatively local model of the Witten's perturbation

Let  $m \in \mathbb{N}$ , and let  $L_1, \dots, L_a$  be compact stratifications. For each  $i = 1, \dots, a$ , let  $N_i$  be a dense stratum of  $L_i$ , let  $k_i = \dim N_i + 1$ , and let  $*_i$  and  $\rho_i$  be the vertex and radial function of  $c(L_i)$ . Then  $M := \mathbb{R}^m \times \prod_{i=1}^a (N_i \times \mathbb{R}_+)$  is a dense stratum of  $A := \mathbb{R}^m \times \prod_{i=1}^a c(L_i)$ . For any relatively compact open neighborhood  $O$  of  $x := (0, *_1, \dots, *_a)$ , all general adapted metrics on  $M$  are quasi-isometric on  $M \cap O$  to a metric of the form  $g = g_0 + \sum_{i=1}^a \rho_i^{2u_i} \tilde{g}_i + (d\rho_i)^2$ , where  $g_0$  is the Euclidean metric on  $\mathbb{R}^m$ , every  $\tilde{g}_i$  is a general adapted metric on  $N_i$ , and  $u_i > 0$ . Suppose that  $g$  is good; i.e., the metrics  $\tilde{g}_i$  are good, and  $u_i \leq 1$ . We can assume that every  $N_i$  is connected, which means that the fiber of  $\lim : \widehat{M} \rightarrow \overline{M}$  over  $x$  consists of a unique point, which can be identified to  $x$  (see [5, Proof of Proposition 3.20]). According to Section 1.4, the rel-local model of a rel-Morse function around a rel-critical point is of the form  $f = \frac{1}{2}(\rho_+^2 - \rho_-^2)$ , where  $\rho_\pm$  is the radial function of

$\mathbb{R}^{m_{\pm}} \times \prod_{i \in I_{\pm}} c(L_i)$ , for some decomposition  $m = m_+ + m_-$  ( $m_{\pm} \in \mathbb{N}$ ), and some partition of  $\{1, \dots, a\}$  into sets  $I_{\pm}$ . The rel-critical set of  $f$  consists only of  $x$ . Let  $d_s, \delta_s, D_s$  and  $\Delta_s$  be the Witten's perturbations of  $d, \delta, D$  and  $\Delta$  on  $\Omega(M)$  induced by  $f$ . Let  $\mathcal{H}_{s, \max/\min} = \bigoplus_r \mathcal{H}_{s, \max/\min}^r = \ker \Delta_{s, \max/\min}$ , with the induced grading. The following result is a direct consequence of Corollary 2.4.9 and [5, Example 9.1 and Lemma 5.1], taking also into account Table 2.13.

**Corollary 2.5.1.** (i)  $\Delta_{s, \max/\min}$  has a discrete spectrum.

(ii) We have

$$\mathcal{H}_{s, \max/\min}^r \cong \bigoplus_{(r_1, \dots, r_a)} \bigotimes_{i=1}^a H_{\max/\min}^{r_i}(N_i),$$

where  $(r_1, \dots, r_a)$  runs in the subset of  $\mathbb{N}^a$  defined by the conditions

$$r = m_- + \sum_{i=1}^a r_i + |I_-|,$$

$$\left. \begin{array}{l} r_i < \frac{k_i-1}{2} + \frac{1}{2u_i} \quad \text{if } i \in I_+ \\ r_i \geq \frac{k_i-1}{2} + \frac{1}{2u_i} \quad \text{if } i \in I_- \end{array} \right\} \text{ for } \mathcal{H}_{s, \max}^r,$$

$$\left. \begin{array}{l} r_i \leq \frac{k_i-1}{2} - \frac{1}{2u_i} \quad \text{if } i \in I_+ \\ r_i > \frac{k_i-1}{2} - \frac{1}{2u_i} \quad \text{if } i \in I_- \end{array} \right\} \text{ for } \mathcal{H}_{s, \min}^r.$$

(iii) If  $e_s \in \mathcal{H}_{s, \max/\min}$  with norm one for every  $s$ , and  $h$  is a bounded measurable function on  $\mathbb{R}_+$  with  $h(\rho) \rightarrow 1$  as  $\rho \rightarrow 0$ , then  $\langle h e_s, e_s \rangle \rightarrow 1$  as  $s \rightarrow \infty$ .

(iv) Let  $0 \leq \lambda_{s, \max/\min, 0} \leq \lambda_{s, \max/\min, 1} \leq \dots$  be the eigenvalues of  $\Delta_{s, \max/\min}$ , repeated according to their multiplicities. Given  $k \in \mathbb{N}$ , if  $\lambda_{s, \max/\min, k} > 0$  for some  $s$ , then  $\lambda_{s, \max/\min, k} > 0$  for all  $s$  and  $\lambda_{s, \max/\min, k} \in O(s)$  as  $s \rightarrow \infty$ .

(v) There is some  $\theta > 0$  such that  $\liminf_k \lambda_{s, \max/\min, k} k^{-\theta} > 0$ .

For every  $\rho > 0$ , let  $B_\rho$  be the open ball of center 0 and radius  $\rho$  in  $\mathbb{R}^m$ , and let

$$U_{x, \rho} = B_\rho \times \prod_{i=1}^a (N_i \times (0, \rho)) \subset M.$$

Taking complex coefficients, by Propositions 2.4.2, 2.4.5 and 2.4.8, the following result clearly boils down to the case of Proposition 2.2.9.

**Proposition 2.5.2.** For  $\alpha \in L^2\Omega(M)$ , let  $\alpha_t = \exp(itD_{s, \max/\min})\alpha$ . If  $\text{supp } \alpha \subset \overline{U_{x, a}}$  for some  $a > 0$ , then  $\text{supp } \alpha_t \subset \overline{U_{x, a+|t|}}$  for all  $t \in \mathbb{R}$ .

## 2.6 Proof of Theorem 1.6.1

This theorem follows from Corollary 2.5.1-(i),(v) with the same arguments as [5, Theorem 1.1]. More precisely, Propositions A.2.1 and A.2.2 are used to globalize the properties of the rel-local model, the min-max principle [58, Theorem XIII.1] is used to show that the properties of the statement are invariant by taking Witten's perturbation defined by rel-admissible functions, and Remark 2.1.7-(iii),(iv) is used to produce rel-admissible cutoff functions and partitions of unity with bounded differential. These functions are needed for the Witten's perturbation and to apply Propositions A.2.1 and A.2.2.

## 2.7 Functional calculus

Let  $M$  be a stratum of a compact stratified space, equipped with a good general adapted metric  $g$ . Let  $f$  be any rel-admissible function on  $M$ , and let  $d_s, \delta_s, D_s$  and  $\Delta_s$  be the corresponding Witten's perturbations of  $d, \delta, D$  and  $\Delta$ . Since  $f$  is rel-admissible, for every  $s$ ,  $\Delta_s - \Delta$  is a homomorphism with uniformly bounded norm by (2.3.4). From (2.3.4) and the min-max principle (see e.g. [58, Theorem XIII.1]), it also follows that  $D(\Delta_{s,\max/\min}) = D(\Delta_{\max/\min})$ ,  $D^\infty(\Delta_{s,\max/\min}) = D^\infty(\Delta_{\max/\min})$ , and that the properties stated in Theorem 1.6.1 can be extended to the perturbation  $\Delta_{s,\max/\min}$ .

For any rapidly decaying function  $\phi$  on  $\mathbb{R}$ ,  $\phi(\Delta_{s,\max/\min})$  is a Hilbert-Schmidt operator on  $L^2\Omega(M)$  by the version of Theorem 1.6.1-(ii) for  $\Delta_{s,\max/\min}$ . In fact,  $\phi(\Delta_{s,\max/\min})$  is of trace class because  $\phi$  can be given as the product of two rapidly decaying functions,  $|\phi|^{1/2}$  and  $\text{sign}(\phi)|\phi|^{1/2}$ , where  $\text{sign}(\phi)(x) = \text{sign}(\phi(x)) \in \{\pm 1\}$  if  $\phi(x) \neq 0$ .

Like in the case of closed manifolds (see e.g. [59, Chapters 5 and 8]), the operator  $\phi(\Delta_{s,\max/\min})$  is given by a Schwartz kernel  $K_s$ , and  $\text{Tr} \phi(\Delta_{s,\max/\min})$  equals the integral of the pointwise trace of  $K_s$  on the diagonal. But we do not know whether  $K_s$  is uniformly bounded because a "rel-Sobolev embedding theorem" is missing [5, Section 19]. Theorem 1.6.1-(ii) becomes important in the arguments exposed here to make up for this lack.

## 2.8 The wave operator

With the notation of Section 2.7, suppose that  $f$  is a rel-Morse function. Take a general chart  $O \equiv O'$  around every  $x \in \text{Crit}_{\text{rel}}(f)$ , like in Section 1.4. Let us add the subindex " $x$ " to the notation of  $M', N_i, m_\pm$  and  $I_\pm$  in this case. Take a good adapted metric  $g'_x$  on  $M'_x$  of the form used in Section 2.5. Consider the

Witten's perturbed operators  $d'_{x,s}$ ,  $\delta'_{x,s}$ ,  $D'_{x,s}$  and  $\Delta'_{x,s}$  on  $\Omega(M'_x)$  determined by the function  $f' := \frac{1}{2}(\rho_+^2 - \rho_-^2)$  (a prime and the subindex  $x$  is added to their notation). Add also a prime to the notation of the sets  $U_{x,\rho}$  of Section 2.5, considered in  $M'_x$ . Let  $\rho_0 > 0$  such that  $\overline{U'_{x,\rho_0}} \subset O'$ . Then, for  $0 < \rho \leq \rho_0$ , there is some open  $U_{x,\rho} \subset M$  so that  $U_{x,\rho} \equiv U'_{x,\rho}$ . Moreover, according to Remark 2.1.4, we can assume  $g|_{U_{x,\rho_0}} \equiv g'_x|_{U'_{x,\rho_0}}$ .

Consider the wave equation

$$\frac{d\alpha_t}{dt} - iD_s\alpha_t = 0, \quad (2.8.1)$$

where  $\alpha_t \in \Omega(M)$  depends smoothly on  $t$ . Given any  $\alpha \in D^\infty(\Delta_{s,\max/\min})$ , its solution with the initial condition  $\alpha_0 = \alpha$  is given by  $\alpha_t = \exp(itD_{s,\max/\min})\alpha$ . Moreover a usual energy estimate shows that such a solution is unique (see e.g. [59, Proposition 7.4]); in fact, given any  $c > 0$ , it is also unique for  $|t| \leq c$ .

**Proposition 2.8.1.** *Let  $0 < a < b < \rho_0$  and  $\alpha \in L^2\Omega(M)$ . The following properties hold for  $\alpha_t = \exp(itD_{s,\max/\min})\alpha$ :*

- (i) *If  $\text{supp } \alpha \subset M \setminus U_{x,a}$ , then  $\text{supp } \alpha_t \subset M \setminus U_{x,a-|t|}$  for  $0 < |t| \leq a$ .*
- (ii) *If  $\text{supp } \alpha \subset \overline{U_{x,a}}$ , then  $\text{supp } \alpha_t \subset \overline{U_{x,a+|t|}}$  for  $0 < |t| \leq b - a$ .*

*Proof.* First, let us prove (ii). We can assume that  $\alpha \in D^\infty(\Delta_{s,\max/\min})$  because  $\exp(itD_{s,\max/\min})$  is bounded. Since  $\text{supp } \alpha \subset \overline{U_{x,a}}$ , we have  $\alpha|_{U_{x,\rho_0}} \equiv \alpha'|_{U'_{x,\rho_0}}$  for a unique  $\alpha' \in \Omega(M'_x)$  supported in  $\overline{U'_{x,a}}$ . We get  $\alpha' \in D^\infty(\Delta'_{x,s,\max/\min})$  because  $\alpha \in D^\infty(\Delta_{s,\max/\min})$ . Let  $\alpha'_t = \exp(itD'_{x,s,\max/\min})\alpha'$ . By Proposition 2.5.2, we have  $\text{supp } \alpha'_t \subset \overline{U'_{x,a+|t|}}$  for  $0 < |t| \leq b - a$ . Then  $\alpha'_t|_{U'_{x,\rho_0}} \equiv \beta_t|_{U_{x,\rho_0}}$  for a unique  $\beta_t \in \Omega(M)$  supported in  $\overline{U_{x,a+|t|}}$ . Now,  $\beta_t \in D^\infty(\Delta_{s,\max/\min})$  because  $\alpha'_t \in D^\infty(\Delta'_{x,s,\max/\min})$ . Moreover  $\beta_t$  satisfies (2.8.1) for  $|t| \leq b - a$  with initial condition  $\beta_0 = \alpha$ . So  $\beta_t = \alpha_t$  by the uniqueness of the solution of (2.8.1), obtaining  $\text{supp } \alpha_t \subset \overline{U_{x,a+|t|}}$ .

Finally, (i) follows from (ii) in the following way. For any  $\beta \in \Omega_0(M)$  with  $\text{supp } \beta \subset \overline{U_{x,a-|t|}}$ , let  $\beta_\tau = \exp(i\tau D_{s,\max/\min})\beta$  for  $\tau \in \mathbb{R}$ . By (ii), we get  $\text{supp } \beta_{-t} \subset \overline{U_{x,a}}$ , and therefore  $\langle \alpha_t, \beta \rangle = \langle \alpha, \beta_{-t} \rangle = 0$ . This shows that  $\text{supp } \alpha_t \subset M \setminus U_{x,a-|t|}$ .  $\square$

*Remark 2.8.2.* The steps given to achieve Proposition 2.8.1 are simpler here than in [5]. In fact, it would be difficult to adapt the arguments of [5] since an expression of  $D^\infty(\Delta_{\max/\min})$  is missing in Section 2.2.2.

## 2.9 Proof of Theorem 1.6.2

This theorem now follows like [5, Theorem 1.2]. Thus the details are omitted.

Consider the notation of Section 2.8. By (2.3.1), the Betti numbers  $\beta_{\max/\min}^r$  are also given by the cohomology of  $d_{s,\max/\min} = d_{\max/\min} + s df \wedge$  on  $D(d_{s,\max/\min}) = e^{-sf} D(d_{\max/\min}) = D(d_{\max/\min})$ .

Let  $\phi$  be a smooth rapidly decaying function on  $\mathbb{R}$  satisfying  $\phi(0) = 1$ . Then the operator  $\phi(\Delta_{s,\max/\min})$  is of trace class (see Section 2.7). Consider the numbers  $\mu_{s,\max/\min}^r = \text{Tr}(\phi(\Delta_{s,\max/\min,r}))$ . Thus the following result follows formally like [59, Proposition 14.3].

**Proposition 2.9.1.** *We have*

$$\sum_{r=0}^k (-1)^{k-r} \beta_{\max/\min}^r \leq \sum_{r=0}^k (-1)^{k-r} \mu_{s,\max/\min}^r \quad (0 \leq k < n),$$

$$\chi_{\max/\min} = \sum_{r=0}^n (-1)^r \mu_{s,\max/\min}^r.$$

For  $\rho \leq \rho_0$ , let  $U_\rho = \bigcup_x U_{x,\rho}$ , with  $x$  running in  $\text{Crit}_{\text{rel}}(f)$ . Fix some  $\rho_1 > 0$  such that  $4\rho_1 < \rho_0$ . Let  $\mathfrak{G}$  and  $\mathfrak{H}$  be the Hilbert subspaces of  $L^2\Omega(M)$  consisting of forms essentially supported in  $M \setminus U_{\rho_1}$  and  $M \setminus U_{3\rho_1}$ , respectively. Since

$$\Delta_{s,\max/\min} = \Delta_{\max/\min} + s \mathbf{Hess} f + s^2 |df|^2$$

on  $D(\Delta_{s,\max/\min}) = D(\Delta_{\max/\min})$  for all  $s \geq 0$  by (2.3.4), it follows that there is some  $C > 0$  so that, if  $s$  is large enough,

$$\Delta_{s,\max/\min} \geq \Delta_{\max/\min} + Cs^2 \quad \text{on } \mathfrak{G} \cap D(\Delta_{\max/\min}). \quad (2.9.1)$$

Let  $h$  be a rel-admissible function on  $M$  such that  $h \geq 0$ ,  $h \equiv 1$  on  $U_{\rho_1}$  and  $h \equiv 0$  on  $M \setminus U_{2\rho_1}$  (Remark 2.1.7-(iii)). Then  $T_{s,\max/\min} = \Delta_{s,\max/\min} + hCs^2$ , with domain  $D(\Delta_{\max/\min})$ , is self-adjoint in  $L^2\Omega(M)$  with a discrete spectrum. Moreover

$$T_{s,\max/\min} \geq \Delta_{\max/\min} + Cs^2 \quad (2.9.2)$$

for  $s$  large enough by (2.9.1).

Take some  $\phi \in \mathcal{S}_{\text{ev}}$  such that  $\phi \geq 0$ ,  $\phi(0) = 1$ ,  $\text{supp } \hat{\phi} \subset [-\rho_1, \rho_1]$ , and  $\phi|_{[0,\infty)}$  is monotone [5, Section 18.2], where  $\hat{\phi}$  denotes its Fourier transform. Write  $\phi(x) = \psi(x^2)$  for some  $\psi \in \mathcal{S}$ . Using Proposition 2.8.1 (i), the argument of the first part of the proof of [59, Lemma 14.6] gives the following.

**Lemma 2.9.2.**  $\psi(\Delta_{s,\max/\min}) = \psi(T_{s,\max/\min})$  on  $\mathfrak{H}$ .

Let  $\Pi : L^2\Omega(M) \rightarrow \mathfrak{H}$  denote the orthogonal projection. According to Section 2.7,  $\psi(\Delta_{s,\max/\min})$  is of trace class for all  $s \geq 0$ . Then the self-adjoint operator  $\Pi \psi(\Delta_{s,\max/\min}) \Pi$  is also of trace class (see e.g. [59, Proposition 8.8]).

**Lemma 2.9.3.**  $\text{Tr}(\Pi \psi(\Delta_{s,\max/\min}) \Pi) \rightarrow 0$  as  $s \rightarrow \infty$ .

*Proof.* This follows like [5, Lemma 18.3], using (2.9.2), the min-max principle and Lemma 2.9.2, and expressing the trace as sum of eigenvalues.  $\square$

The following is a direct consequence of Corollary 2.5.1 (i)–(iv).

**Corollary 2.9.4.** *If  $h$  is a bounded measurable function on  $\mathbb{R}_+$  such that  $h(\rho) \rightarrow 1$  as  $\rho \rightarrow 0$ , then  $\text{Tr}(h(\rho) \phi(\Delta'_{x,s,\max/\min,r})) \rightarrow \nu_{x,\max/\min}^r$  as  $s \rightarrow \infty$ .*

For every  $x \in \text{Crit}_{\text{rel}}(f)$ , let  $\tilde{\mathfrak{H}}_x \subset L^2\Omega(M)$  and  $\tilde{\mathfrak{H}}'_x \subset L^2\Omega(M'_x)$  be the Hilbert subspaces of differential forms supported in  $\overline{U_{x,3\rho_1}}$  and  $\overline{U'_{x,3\rho_1}}$ , respectively. We have  $\tilde{\mathfrak{H}}_x \equiv \tilde{\mathfrak{H}}'_x$  because  $g \equiv g'_x$  on  $U_{x,\rho_0} \equiv U'_{x,\rho_0}$ . Moreover  $\Delta_s \equiv \Delta'_{x,s}$  on differential forms supported in  $U_{x,\rho_0} \equiv U'_{x,\rho_0}$ . By using Proposition 2.8.1 (ii), the argument of the first part of the proof of [59, Lemma 14.6] can be adapted to show the following.

**Lemma 2.9.5.**  $\phi(\Delta_{s,\max/\min}) \equiv \phi(\Delta'_{x,s,\max/\min})$  on  $\tilde{\mathfrak{H}}_x \equiv \tilde{\mathfrak{H}}'_x$  for all  $x \in \text{Crit}_{\text{rel}}(f)$ .

For every  $x \in \text{Crit}_{\text{rel}}(f)$ , let  $\tilde{\Pi}_x : L^2\Omega(M) \rightarrow \tilde{\mathfrak{H}}_x$  and  $\tilde{\Pi}'_x : L^2\Omega(M'_x) \rightarrow \tilde{\mathfrak{H}}'_x$  denote the orthogonal projections. Since the subspaces  $\tilde{\mathfrak{H}}_x$  are orthogonal to each other,  $\tilde{\Pi} := \sum_x \tilde{\Pi}_x : L^2\Omega(M) \rightarrow \tilde{\mathfrak{H}} := \sum_x \tilde{\mathfrak{H}}_x$  is the orthogonal projection.

**Lemma 2.9.6.**  $\text{Tr}(\tilde{\Pi} \phi(\Delta_{s,\max/\min,r}) \tilde{\Pi}) \rightarrow \nu_{\max/\min}^r$  as  $s \rightarrow \infty$ .

*Proof.* This follows like [5, Lemma 18.6], using Corollary 2.9.4 and Lemma 2.9.5, and, for all  $x \in \text{Crit}_{\text{rel}}(f)$ , considering  $\tilde{\Pi}'_x$  as the multiplication operator by the characteristic function of  $U'_{x,3\rho_1}$ .  $\square$

Since  $\Pi + \tilde{\Pi} = 1$ , Theorem 1.6.2 follows from Proposition 2.9.1, and Lemmas 2.9.3 and 2.9.6.



---

## Chapter 3

# Lefschetz trace formula

---

### Contents

|   |    |
|---|----|
| 3.1 Reduction to the contribution from the fixed points . . . . . | 66 |
| 3.2 Lefschetz trace formula on a cone . . . . .                   | 68 |
| 3.3 Contribution from the singular fixed points . . . . .         | 71 |

In this chapter, consider the notation of Section 1.5. Then let  $A$  be a compact orientable stratification of dimension  $n$  with isolated singularities and equipped with a good adapted metric  $g$  over its regular part,  $\text{reg}(A) = M$ . Consider a morphism of stratifications  $\psi : A \rightarrow A$ . Recall that we assume that  $\psi|_M$  is a smooth map by definition of morphism (Section 1.2). Let  $\psi^*$  be the endomorphism of  $(\Omega(M), d)$  induced by  $\psi$ , and let  $\text{Fix}(\psi)$  denote the set of fixed points of  $\psi$ . For every  $q \in \text{sing}(A) = A \setminus M$ , there exists a conic chart  $O_q \equiv c_{\epsilon_q}(L_q)$  centered at  $q$  such that  $\text{depth } L_q = 0$  (i.e.,  $L_q$  is a compact smooth manifold).

The following hypotheses are assumed on  $\psi$ :

- (a) The morphism  $\psi$  fixes every singular point of  $A$ .
- (b) The set  $\text{Fix}(\psi)$  contains only simple fixed points.
- (c) For every  $q \in \text{sing}(A)$ , the smooth maps  $F_q : L_q \times [0, \epsilon_q) \rightarrow [0, \epsilon_q)$  and  $G_q : L_q \times [0, \epsilon_q) \rightarrow L_q$  introduced in (1.5.1) do not depend on  $\rho$  around  $q$ .

Hypothesis (c) means that

$$\psi(\rho, x) = (\rho F_q(x), G_q(x))$$

on every small enough conic chart  $O_q$ .

The adapted metric  $g|_{O_q}$  is quasi-isometric to the metric  $\rho^{2u} \tilde{g}_q + (d\rho)^2$  on the manifold  $L_q \times (0, \epsilon_q)$ , where  $\tilde{g}_q$  is a Riemannian metric on  $L_q$  and  $0 < u \leq 1$ . There exists a *maximum/minimum Lefschetz number* associated to the morphism  $\psi$ , defined by (1.5.2). The aim of this chapter is to give a proof of Theorem 1.6.3, which is a Lefschetz trace formula in this setting.

### 3.1 Reduction to the contribution from the fixed points

Theorem 1.6.1 and usual arguments from standard Hodge Theory establish that each cohomology group  $H_{\max/\min}^r(M)$  is represented by the space  $\mathcal{H}_{\max/\min}^r$  of harmonic  $r$ -forms of  $\Delta_{\max/\min}$ . Then we have that

$$\mathrm{tr}(\psi^* \text{ on } H_{\max/\min}^r(M)) = \mathrm{Tr}(\psi^* P_r), \quad (3.1.1)$$

where  $P_r : L^2\Omega^r(M) \rightarrow \mathcal{H}_{\max/\min}^r$  is the orthogonal projection. By (1.5.2) and (3.1.1), we get

$$L_{\max/\min}(\psi) = \sum_{r=0}^n (-1)^r \mathrm{Tr}(\psi^* P_r). \quad (3.1.2)$$

An adaptation of [59, Lemma 10.5] can be made in this context, resulting that the smoothing kernel of  $e^{-t\Delta_{\max/\min,r}}$  tends to the smoothing kernel of  $P_r$  as  $t \rightarrow \infty$ , in the  $C^\infty$  topology. This argument uses that  $\Delta_{\max/\min}$  has a discrete spectrum, as stated Theorem 1.6.1-(i). Therefore

$$\mathrm{Tr}(\psi^* P_r) = \lim_{t \rightarrow \infty} \mathrm{Tr}(\psi^* e^{-t\Delta_{\max/\min,r}}). \quad (3.1.3)$$

So (3.1.2) and (3.1.3) give that

$$L_{\max/\min}(\psi) = \lim_{t \rightarrow \infty} \sum_{r=0}^n (-1)^r \mathrm{Tr}(\psi^* e^{-t\Delta_{\max/\min,r}}).$$

The arguments of [59, Proposition 10.7] can also be adapted here, concluding that

$$\sum_{r=0}^n (-1)^r \mathrm{Tr}(\psi^* e^{-t\Delta_{\max/\min,r}})$$

is constant in  $t$ . Thus, for any  $t > 0$ ,

$$L_{\max/\min}(\psi) = \sum_{r=0}^n (-1)^r \mathrm{Tr}(\psi^* e^{-t\Delta_{\max/\min,r}}). \quad (3.1.4)$$

In addition, a general property of smoothing operators establishes that their trace is given by the integral of the pointwise trace of their smoothing kernel (see [59, Theorem 8.12]). So

$$\mathrm{Tr}(\psi^* e^{-t\Delta_{\max/\min,r}}) = \int_M \mathrm{tr}(\psi^* K_t^r(\psi(p), p)) \mathrm{vol}(p), \quad (3.1.5)$$

where  $K_t^r$  denotes the heat kernel of  $e^{-t\Delta_{\max/\min,r}}$ .

The right hand side of (3.1.5) can be decomposed in the following way:

$$\begin{aligned} \int_M \operatorname{tr}(\psi^* K_t^r(\psi(p), p)) \operatorname{vol}(p) &= \sum_{q \in \operatorname{Fix}(\psi)} \int_{M \cap O_q} \operatorname{tr}(\psi^* K_t^r(\psi(p), p)) \operatorname{vol}(p) \\ &+ \int_{\check{M}} \operatorname{tr}(\psi^* K_t^r(\psi(p), p)) \operatorname{vol}(p). \end{aligned} \quad (3.1.6)$$

Here, each  $O_q$  is the domain of a chart centered at the corresponding fixed point  $q$ , and

$$\check{M} = M \setminus \bigcup_{q \in \operatorname{Fix}(\psi)} O_q$$

is a compact subset of the regular part  $M$ . For every regular fixed point  $q$ , the set

$$M \cap O_q = O_q \equiv O'_q = B(0, \epsilon_q) \times c(\emptyset) \equiv B(0, \epsilon_q) \subset \mathbb{R}^n$$

is just a usual chart around  $q$  in  $M$ ; whereas for every singular (fixed) point  $q$ , the set

$$M \cap O_q = O_q \setminus \{q\} \equiv c_{\epsilon_q}(L_q) \setminus \{q\} \equiv L_q \times (0, \epsilon_q)$$

is the regular part of a conic chart centered at  $q$ .

The continuity of  $\psi$  and the compactness of  $\check{M}$  imply that  $\{(\psi(p), p) \mid p \in \check{M}\}$  is a compact subset of  $M \times M$ . It is disjoint from the compact diagonal of  $\check{M} \times \check{M}$ , denoted by  $\Delta_{\check{M}} \subset \Delta_M \subset M \times M$ . Then, applying the asymptotic behaviour of the heat kernel given by Theorem A.2.3, we obtain

$$\lim_{t \rightarrow 0} \int_{\check{M}} \operatorname{tr}(\psi^* K_t^r(\psi(p), p)) \operatorname{vol}(p) = \int_{\check{M}} \lim_{t \rightarrow 0} \operatorname{tr}(\psi^* K_t^r(\psi(p), p)) \operatorname{vol}(p) = 0,$$

like in the proof of [9, Theorem 5]. This fact gives the null contribution of the non-fixed points to the Lefschetz number. Consequently, from (3.1.4), (3.1.5) and (3.1.6), we have

$$\begin{aligned} L_{\max/\min}(\psi) &= \lim_{t \rightarrow 0} \sum_{r=0}^n (-1)^r \operatorname{Tr}(\psi^* e^{-t\Delta_{\max/\min, r}}) \\ &= \lim_{t \rightarrow 0} \left( \sum_{q \in \operatorname{Fix}(\psi)} \sum_{r=0}^n (-1)^r \int_{M \cap O_q} \operatorname{tr}(\psi^* K_t^r(\psi(p), p)) \operatorname{vol}(p) \right), \end{aligned}$$

which can be decomposed as sum of the respective contributions from the regular and

singular fixed points,

$$\lim_{t \rightarrow 0} \left( \sum_{q \in \text{Fix}(\psi) \cap M} \sum_{r=0}^n (-1)^r \int_{O_q} \text{tr}(\psi^* K_t^r(\psi(p), p)) \text{vol}(p) \right) \quad (3.1.7)$$

$$+ \lim_{t \rightarrow 0} \left( \sum_{q \in \text{sing}(A)} \sum_{r=0}^n (-1)^r \int_{O_q \setminus \{q\}} \text{tr}(\psi^* K_t^r(\psi(p), p)) \text{vol}(p) \right). \quad (3.1.8)$$

Moreover, by Corollary A.2.5 (and the asymptotic ideas used in proof of Theorem A.2.4), it follows that (3.1.7) is equal to

$$\sum_{q \in \text{Fix}(\psi) \cap M} \text{sign det}(1 - T_q \psi). \quad (3.1.9)$$

The computation of (3.1.8) is included in Section 3.3.

### 3.2 Lefschetz trace formula on a cone

Let  $L$  be a non-empty compact stratified space and consider the dense stratum  $N$  of  $L$ . Let  $f = \frac{1}{2}\rho^2$  be the model rel-Morse function on the stratum  $N \times \mathbb{R}_+$  of the cone  $c(L)$ , whose only rel-critical point is the vertex. Consider a good adapted metric  $\rho^{2u}\tilde{g} + (d\rho)^2$  on  $N \times \mathbb{R}_+$ , where  $\tilde{g}$  is a good adapted metric on  $N$  and  $0 < u \leq 1$ . In this section, let  $\psi : c(L) \rightarrow c(L)$  be a morphism of (non-compact) stratifications, smooth on  $N \times \mathbb{R}_+$  and satisfying hypotheses (a)–(c). In particular, the vertex is a simple fixed point of  $\psi$ , and

$$\psi(\rho, x) = (\rho F(x), G(x))$$

for all  $(\rho, x) \in N \times \mathbb{R}_+$ . For  $s > 0$ , let  $d_s, \delta_s, D_s$  and  $\Delta_s$  be the corresponding Witten's perturbations of  $d, \delta, D$  and  $\Delta$  on  $N \times \mathbb{R}_+$  (see (2.3.1)–(2.3.3)). Let also  $\psi_s^* = e^{-sf}\psi^*e^{sf}$ , which is called *the Witten's perturbation* of the endomorphism  $\psi^*$ . Then

$$e^{sf} : (\mathcal{D}(d_{s,\text{max/min}}), d_{s,\text{max/min}}) \rightarrow (\mathcal{D}(d_{\text{max/min}}), d_{\text{max/min}})$$

is a Hilbert complex isomorphism [5, § 18.1]. Hence,

$$\mathcal{H}_{\text{max/min}}^r = \ker \Delta_{\text{max/min},r} \equiv \ker \Delta_{s,\text{max/min},r} = \mathcal{H}_{s,\text{max/min}}^r,$$

for  $r = 0, \dots, n$ . As a consequence, given an orthonormal frame  $\{e_i\}$  of the Hilbert space  $L^2\Omega^r(N \times \mathbb{R}_+)$ , we get

$$\text{Tr}(\psi^* P_r) = \sum_i \langle \psi^* P_r e_i, e_i \rangle = \sum_i \langle \psi_s^* P_{s,r} e_i, e_i \rangle = \text{Tr}(\psi_s^* P_{s,r}), \quad (3.2.1)$$

where  $P_{s,r} : L^2\Omega^r(N \times \mathbb{R}_+) \rightarrow \mathcal{H}_{s,\max/\min}^r$  is the orthogonal projection. Moreover, given an orthonormal frame  $\{\xi_j\}$  of  $\mathcal{H}_{s,\max/\min}^r$ , we have

$$\mathrm{Tr}(\psi_s^* P_{s,r}) = \sum_j \langle \psi_s^* \xi_j, \xi_j \rangle. \quad (3.2.2)$$

From Proposition 2.4.8, it follows that

$$\begin{aligned} \mathcal{H}_{s,\max/\min} &= \ker \Delta_{s,\max/\min} = \ker \widehat{\Delta}_{s,\max/\min} \\ &= \ker \left( \bigoplus_{\gamma} \Delta_{s,\gamma} \oplus \widehat{\bigoplus_{\mu} \bigoplus_{\alpha+\beta} \Delta_{s,\alpha,\beta}} \right) \\ &= \bigoplus_{\gamma} \ker \Delta_{s,\gamma} \oplus \widehat{\bigoplus_{\mu} \bigoplus_{\alpha+\beta} \ker \Delta_{s,\alpha,\beta}} \\ &= \bigoplus_{\gamma} \ker \Delta_{s,\gamma} = \bigoplus_{\gamma} \mathcal{H}_{s,\gamma} = \bigoplus_{\gamma} (\mathcal{H}_{s,\gamma}^r \oplus \mathcal{H}_{s,\gamma}^{r+1}), \end{aligned}$$

where  $\gamma$  runs in an orthonormal frame  $\mathcal{C}_{\max/\min,0}$  of  $\widetilde{\mathcal{H}}_{\max/\min} = \ker \widetilde{\Delta}_{\max/\min}$ ,  $\mu$  runs in the positive spectrum of  $\widetilde{D}_{\max/\min}$ , and  $\alpha + \beta$  runs in an orthonormal frame  $\mathcal{C}_{\max/\min,\mu}$  of the  $\mu$ -eigenspace of  $\widetilde{D}_{\max/\min}$ . Then, applying Proposition 2.4.9-(ii) and standard arguments from Hodge Theory (see Tables 2.11 and 2.12, where only the positive sign cases must be considered), for  $r = 0, \dots, n-1$ , we obtain

$$\mathcal{H}_{s,\max}^r = \bigoplus_{\gamma \in \mathcal{C}_{\max,0}^r} \mathcal{H}_{s,\gamma}^r \equiv \bigoplus_{\gamma \in \mathcal{C}_{\max,0}^r} \langle \gamma \rangle = \widetilde{\mathcal{H}}_{\max}^r \equiv H_{\max}^r(N)$$

if  $\kappa > -1/2$ , and  $\mathcal{H}_{s,\max}^r = 0$  if  $\kappa \leq -1/2$ . Analogously, for  $r = 0, \dots, n-1$ ,

$$\mathcal{H}_{s,\min}^r = \bigoplus_{\gamma \in \mathcal{C}_{\min,0}^r} \mathcal{H}_{s,\gamma}^r \equiv \bigoplus_{\gamma \in \mathcal{C}_{\min,0}^r} \langle \gamma \rangle = \widetilde{\mathcal{H}}_{\min}^r \equiv H_{\min}^r(N)$$

if  $\kappa \geq 1/2$ , and  $\mathcal{H}_{s,\min}^r = 0$  if  $\kappa < 1/2$ . In addition,  $\mathcal{H}_{s,\max/\min}^n = 0$ , for all  $\kappa \in \mathbb{R}$ .

Remember that  $\langle \gamma \rangle \subset L^2\mathcal{E}_{\gamma}^r = L^2_{\kappa,+}\mathcal{E}_{\gamma}^r \equiv L^2_{\kappa,+}$  for all the harmonic forms  $\gamma \in \mathcal{C}_{\max/\min,0}^r$ . By Proposition 2.4.2, the Laplacian  $\Delta_{s,\gamma} = \Delta_{s,\gamma,r} \oplus \Delta_{s,\gamma,r+1}$  is associated (up to a shift of degree) to the maximum/minimum extension of the operator  $\Delta = \Delta_0 \oplus \Delta_1$  studied in Section 2.2.1. So  $\mathcal{H}_{s,\gamma}^r = \ker \Delta_{s,\gamma,r}$  corresponds to  $\Delta_{\max/\min,0}$  by the unitary isomorphism  $L^2\mathcal{E}_{\gamma}^r \rightarrow L^2(E_0)$  defined by the multiplication operator  $\rho^{\kappa} : L^2_{\kappa,+} \rightarrow L^2_{+}$ . The non-trivial case for  $\mathcal{H}_{s,\max/\min}^r$  determines a condition on  $\kappa$  yielding  $\Delta_{\max/\min,0} = \mathcal{A}_1$ , according to Proposition 2.2.1 (see Table 2.3). So we must consider

$$\sigma = a = \kappa = (n - 2r - 1) \frac{u}{2}$$

in Proposition 4.7.1, obtaining that  $\rho^\kappa \mathcal{S}_{\text{ev},+} \subset L_+^2$  is the smooth core of  $\Delta_{\text{max/min},0}$ , and

$$\begin{aligned} \chi_0(\rho) &= \chi_{s,\kappa,\kappa,0}(\rho) = \sqrt{2} \rho^\kappa \phi_{s,\kappa,0,+}(\rho) \\ &= \sqrt{2} \rho^\kappa s^{(2\kappa+1)/4} \Gamma(\kappa + \frac{1}{2})^{-\frac{1}{2}} e^{-s\rho^2/2} \end{aligned}$$

is a normalized generator of the space of harmonic eigenfunctions (i.e., associated to the eigenvalue 0 of multiplicity one, given for  $\mathcal{A}_1^+$  by the integer  $k = 0$  in Table 2.2). Therefore  $\mathcal{S}_{\text{ev},+} \gamma \subset L^2 \mathcal{E}_\gamma^r$  is the smooth core of  $\Delta_{s,\gamma,r}$ , and

$$\xi(\rho, x) = \sqrt{2} \phi_{s,\kappa,0,+}(\rho) \gamma(x) = \sqrt{2} s^{(2\kappa+1)/4} \Gamma(\kappa + \frac{1}{2})^{-\frac{1}{2}} e^{-s\rho^2/2} \gamma(x)$$

is a normalized harmonic eigenform of  $\mathcal{H}_{s,\text{max/min}}^r$ .

By hypotheses (a)–(c),

$$\psi^* \xi(\rho, x) = \sqrt{2} s^{(2\kappa+1)/4} \Gamma(\kappa + \frac{1}{2})^{-\frac{1}{2}} e^{-s(\rho F(x))^2/2} (G^* \gamma)(x).$$

Thus

$$\begin{aligned} e^{s(\psi^* f - f)} \psi^* \xi &= \sqrt{2} s^{(2\kappa+1)/4} \Gamma(\kappa + \frac{1}{2})^{-\frac{1}{2}} e^{-s\rho^2/2} G^* \gamma \\ &= \sqrt{2} \phi_{s,\kappa,0,+}(\rho) G^* \gamma \end{aligned}$$

because

$$(\psi^* f - f)(\rho, x) = f(\psi(\rho, x)) - f(\rho, x) = \frac{1}{2} (\rho F(x))^2 - \frac{1}{2} \rho^2.$$

Then

$$\begin{aligned} \langle \psi_s^* \xi, \xi \rangle &= \langle e^{s(\psi^* f - f)} \psi_s^* \xi, \xi \rangle \\ &= \langle \sqrt{2} \phi_{s,\kappa,0,+}(\rho) G^* \gamma, \sqrt{2} \phi_{s,\kappa,0,+}(\rho) \gamma \rangle \\ &= \|\sqrt{2} \phi_{s,\kappa,0,+}(\rho)\|_{L_{\kappa,+}^2}^2 \langle G^* \gamma, \gamma \rangle \\ &= \|\sqrt{2} \rho^\kappa \phi_{s,\kappa,0,+}(\rho)\|_{L_+^2}^2 \langle G^* \gamma, \gamma \rangle \\ &= \langle G^* \gamma, \gamma \rangle. \end{aligned} \tag{3.2.3}$$

Combining (3.2.2) and (3.2.3), we obtain

$$\text{Tr}(\psi_s^* P_{s,r}) = \sum_{\gamma \in \mathcal{C}_{\text{max/min},0}^r} \langle G^* \gamma, \gamma \rangle \tag{3.2.4}$$

for  $r = 0, \dots, n-1$ ; whereas  $\text{Tr}(\psi_s^* P_{s,n}) = 0$ . By (3.1.2), (3.2.1) and (3.2.4), we deduce

$$\begin{aligned}
 L_{\max/\min}(\psi) &= \sum_{r=0}^{n-1} (-1)^r \sum_{\gamma \in \mathcal{C}_{\max/\min,0}^r} \langle G^* \gamma, \gamma \rangle \\
 &= \sum_{r=0}^{n-1} (-1)^r \text{tr}(G^* \text{ on } \tilde{\mathcal{H}}_{\max/\min}^r) \\
 &= \sum_{r=0}^{n-1} (-1)^r \text{tr}(G^* \text{ on } H_{\max/\min}^r(N)) = L_{\max/\min}(G). \quad (3.2.5)
 \end{aligned}$$

In particular, if  $N = L$  is a compact smooth manifold, it happens that

$$L_{\max/\min}(\psi) = L_{\max/\min}(G) = L(G), \quad (3.2.6)$$

since by completeness there is only one i.b.c. (see Section 1.1). Here  $L(G)$  denotes the Lefschetz number associated to the smooth map  $G : L \rightarrow L$  (see [59, Equation (10.1)]).

### 3.3 Contribution from the singular fixed points

Consider the orthogonal projections  $\Pi$  and  $\tilde{\Pi}$  introduced in Section 2.9, but constructed using charts around the singular points of  $A$  (instead of around the rel-critical points of the chosen rel-Morse function  $f$ ). Applying [59, Theorem 8.12 and Proposition 10.7], the Hilbert complex isomorphism given by  $e^{s\rho^2/2}$  and Lemma 2.9.5, it follows that (3.1.8) is equal to

$$\begin{aligned}
 &\lim_{t \rightarrow 0} \left( \sum_{r=0}^n (-1)^r \text{Tr}(\psi_s^* e^{-t\Delta_{\max/\min,r}} \tilde{\Pi}) \right) \\
 &= \lim_{t \rightarrow \infty} \left( \sum_{r=0}^n (-1)^r \text{Tr}(\psi_s^* e^{-t\Delta_{\max/\min,r}} \tilde{\Pi}) \right) \\
 &= \sum_{r=0}^n (-1)^r \lim_{t \rightarrow \infty} \text{Tr}(\psi_s^* e^{-t\Delta_{\max/\min,r}} \tilde{\Pi}) \\
 &= \sum_{r=0}^n (-1)^r \lim_{t \rightarrow \infty} \text{Tr}(\psi_s^* e^{-t\Delta_{s,\max/\min,r}} \tilde{\Pi})
 \end{aligned}$$

$$\begin{aligned}
 &= \sum_{q \in \text{sing}(A)} \sum_{r=0}^n (-1)^r \lim_{t \rightarrow \infty} \text{Tr}(\psi_s^* e^{-t\Delta_{s, \max/\min, r}} \tilde{\Pi}_q) \\
 &= \sum_{q \in \text{sing}(A)} \sum_{r=0}^n (-1)^r \lim_{t \rightarrow \infty} \text{Tr}(\psi_s^* e^{-t\Delta'_{q, s, \max/\min, r}} \tilde{\Pi}_q). \tag{3.3.1}
 \end{aligned}$$

Observe that (3.3.1) is independent of the Witten's parameter  $s$ . The heat operator  $e^{-t\Delta'_{q, s, \max/\min, r}}$  is of trace class, and  $\psi_s^*$  is a bounded operator. Then

$$|\text{Tr}(\psi_s^* e^{-t\Delta'_{q, s, \max/\min, r}} \Pi_q)| \leq \|\psi_s^*\| |\text{Tr}(e^{-t\Delta'_{q, s, \max/\min, r}} \Pi_q)|$$

by the general properties of trace class operators. But Lemma 2.9.3 gives

$$\text{Tr}(e^{-t\Delta'_{q, s, \max/\min, r}} \Pi_q) \rightarrow 0 \quad \text{as } s \rightarrow \infty.$$

Hence

$$\text{Tr}(\psi_s^* e^{-t\Delta'_{q, s, \max/\min, r}} \Pi_q) \rightarrow 0 \quad \text{as } s \rightarrow \infty.$$

Consequently, since  $1 = \Pi_q + \tilde{\Pi}_q$ ,

$$\begin{aligned}
 \text{Tr}(\psi_s^* e^{-t\Delta'_{q, s, \max/\min, r}}) &= \text{Tr}(\psi_s^* e^{-t\Delta'_{q, s, \max/\min, r}} \Pi_q) \\
 &\quad + \text{Tr}(\psi_s^* e^{-t\Delta'_{q, s, \max/\min, r}} \tilde{\Pi}_q) \\
 &\rightarrow \text{Tr}(\psi_s^* e^{-t\Delta'_{q, s, \max/\min, r}} \tilde{\Pi}_q) \quad \text{as } s \rightarrow \infty.
 \end{aligned}$$

From (3.3.1), (3.2.4), (3.2.5) and (3.2.6), it follows that (3.1.8) is equal to

$$\begin{aligned}
 &\sum_{q \in \text{sing}(A)} \sum_{r=0}^n (-1)^r \lim_{t \rightarrow \infty} \text{Tr}(\psi_s^* e^{-t\Delta'_{q, s, \max/\min, r}}) \\
 &= \sum_{q \in \text{sing}(A)} \sum_{r=0}^n (-1)^r \text{Tr}(\psi_s^* P_{q, s, r}) \\
 &= \sum_{q \in \text{sing}(A)} \sum_{r=0}^{n-1} (-1)^r \sum_{\gamma \in \mathcal{C}_{q, \max/\min, 0}^r} \langle G_q^* \gamma, \gamma \rangle \\
 &= \sum_{q \in \text{sing}(A)} L(G_q), \tag{3.3.2}
 \end{aligned}$$

because (3.3.1) is independent of  $s$ .

Finally, applying (3.1.9) and (3.3.2), we get

$$L_{\max/\min}(\psi) = \sum_{q \in \text{Fix}(\psi) \cap M} \text{sign det}(1 - T_q \psi) + \sum_{q \in \text{sing}(A)} L(G_q),$$

which is the statement of Theorem 1.6.3.

# Dunkl Harmonic Oscillator

## Contents

|   |            |
|---|------------|
| <b>4.1 Preliminaries</b> . . . . .  | <b>74</b>  |
| <b>4.2 The sesquilinear form <math>t</math></b> . . . . .   | <b>76</b>  |
| <b>4.3 Scalar products of mixed generalized Hermite functions</b> . . .   | <b>90</b>  |
| 4.3.1 Case where $\sigma = \theta \neq \tau$ and $\tau - \sigma \notin -\mathbb{N}$ . . . . .                     | 91         |
| 4.3.2 Case where $\sigma \neq \theta \neq \tau$ and $\sigma - \theta, \tau - \theta \notin -\mathbb{N}$ . . . . . | 94         |
| <b>4.4 The sesquilinear form <math>t'</math></b> . . . . .  | <b>99</b>  |
| 4.4.1 Case where $\sigma = \theta = \tau$ . . . . .   | 99         |
| 4.4.2 Case where $\sigma = \theta \neq \tau$ and $\tau - \sigma \notin -\mathbb{N}$ . . . . .                     | 99         |
| 4.4.3 Case where $\sigma \neq \theta = \tau$ and $\sigma - \theta \notin -\mathbb{N}$ . . . . .                   | 100        |
| 4.4.4 Case where $\sigma \neq \theta = \tau + 1$ and $\sigma - \tau - 1 \notin -\mathbb{N}$ . . . . .             | 101        |
| 4.4.5 Case where $\sigma \neq \theta \neq \tau$ and $\sigma - \theta, \tau - \theta \notin -\mathbb{N}$ . . . . . | 103        |
| 4.4.6 Proof of Theorem 1.10.3 . . . . .   | 104        |
| <b>4.5 A preliminary estimate</b> . . . . .   | <b>106</b> |
| 4.5.1 Statement . . . . .   | 106        |
| 4.5.2 Proof of Lemma 4.5.1 . . . . .  | 107        |
| <b>4.6 The main estimates</b> . . . . .   | <b>121</b> |
| <b>4.7 Operators induced on <math>\mathbb{R}_+</math></b> . . . . .   | <b>126</b> |

In this chapter, consider the notation of Section 1.10. Then let  $\mathcal{S} = \mathcal{S}_{\text{ev}} \oplus \mathcal{S}_{\text{odd}}$  be the Schwartz space on  $\mathbb{R}$ , considered with its Fréchet topology and decomposed as direct sum of subspaces of even and odd functions. Let  $x$  denote the standard coordinate of  $\mathbb{R}$ . The multiplication operator  $x$  interchanges the components, because  $\mathcal{S}_{\text{odd}} = x\mathcal{S}_{\text{ev}}$  and the function  $|x|^{2\sigma}$  is even. Let  $L_\sigma^2 = L^2(\mathbb{R}, |x|^{2\sigma} dx)$  ( $\sigma \in \mathbb{R}$ ), whose scalar product and norm are denoted by  $\langle \cdot, \cdot \rangle_\sigma$  and  $\|\cdot\|_\sigma$ . The above decomposition of  $\mathcal{S}$  extends to an orthogonal decomposition  $L_\sigma^2 = L_{\sigma,\text{ev}}^2 \oplus L_{\sigma,\text{odd}}^2$ . The

subspace  $\mathcal{S}$  is dense in  $L^2_\sigma$  if  $\sigma > -\frac{1}{2}$ , and  $\mathcal{S}_{\text{odd}}$  is dense in  $L^2_{\tau,\text{odd}}$  if  $\tau > -\frac{3}{2}$ . So we assume  $\sigma > -\frac{1}{2}$  and  $\tau > -\frac{3}{2}$ , unless otherwise stated.

The harmonic oscillator is the operator  $H = -\frac{d^2}{dx^2} + s^2x^2$  ( $s > 0$ ) in  $L^2_0$  with domain  $D(H) = \mathcal{S}$ . The Dunkl operator on  $\mathbb{R}$  is the operator  $T$  in  $L^2_\sigma$ , with  $D(T) = \mathcal{S}$ , determined by  $T = \frac{d}{dx}$  on  $\mathcal{S}_{\text{ev}}$  and  $T = \frac{d}{dx} + 2\sigma x^{-1}$  on  $\mathcal{S}_{\text{odd}}$ . The Dunkl harmonic oscillator on  $\mathbb{R}$  is  $J = -T^2 + s^2x^2$  in  $L^2_\sigma$  with  $D(J) = \mathcal{S}$ . Thus  $J$  preserves the above decomposition of  $\mathcal{S}$ , being  $J_{\text{ev}} = H - 2\sigma x^{-1} \frac{d}{dx}$  and  $J_{\text{odd}} = H - 2\sigma \frac{d}{dx} x^{-1}$ . This  $J$  is essentially self-adjoint, and the spectrum of its closure  $\bar{J}$  is well known; in particular,  $\bar{J} > 0$ . In fact, even for  $\tau > -\frac{3}{2}$ , the operator  $J_{\tau,\text{odd}}$  is defined in  $L^2_{\tau,\text{odd}}$  with  $D(J_{\tau,\text{odd}}) = \mathcal{S}_{\text{odd}}$  because it is a conjugation of  $J_{\tau+1,\text{ev}}$  by a unitary operator (Section 4.1). Let also  $J_{\sigma,\tau} = J_{\sigma,\text{ev}} \oplus J_{\tau,\text{odd}}$  in  $L^2_{\sigma,\tau} = L^2_{\sigma,\text{ev}} \oplus L^2_{\tau,\text{odd}}$ , with  $D(J_{\sigma,\tau}) = \mathcal{S}$ . The aim of this chapter is to use different analytic techniques in order to prove Theorems 1.10.1 and 1.10.3, which describe certain perturbations of  $J_\sigma$  and  $J_{\sigma,\tau}$ , respectively. The contents of this chapter are included in [6].

## 4.1 Preliminaries

The Dunkl annihilation and creation operators are  $B = sx + T$  and  $B' = sx - T$  ( $s > 0$ ). Like  $J$ , the operators  $B$  and  $B'$  are considered in  $L^2_\sigma$  with domain  $\mathcal{S}$ . They are perturbations of the usual annihilation and creation operators. The operators  $T$ ,  $B$ ,  $B'$  and  $J$  are continuous on  $\mathcal{S}$ . The following properties hold [4, 60]:

- $B'$  is adjoint of  $B$ , and  $J$  is essentially self-adjoint.
- The spectrum of  $\bar{J}$  consists of the eigenvalues<sup>1</sup>  $(2k + 1 + 2\sigma)s$  ( $k \in \mathbb{N}$ ), of multiplicity one.
- The corresponding normalized eigenfunctions  $\phi_k$  are inductively defined by

$$\phi_0 = s^{(2\sigma+1)/4} \Gamma(\sigma + \frac{1}{2})^{-\frac{1}{2}} e^{-sx^2/2}, \quad (4.1.1)$$

$$\phi_k = \begin{cases} (2ks)^{-\frac{1}{2}} B' \phi_{k-1} & \text{if } k \text{ is even} \\ (2(k+2\sigma)s)^{-\frac{1}{2}} B' \phi_{k-1} & \text{if } k \text{ is odd} \end{cases} \quad (k \geq 1). \quad (4.1.2)$$

- The eigenfunctions  $\phi_k$  also satisfy

$$B\phi_0 = 0, \quad (4.1.3)$$

$$B\phi_k = \begin{cases} (2ks)^{\frac{1}{2}} \phi_{k-1} & \text{if } k \text{ is even} \\ (2(k+2\sigma)s)^{\frac{1}{2}} \phi_{k-1} & \text{if } k \text{ is odd} \end{cases} \quad (k \geq 1). \quad (4.1.4)$$

---

<sup>1</sup>It is assumed that  $0 \in \mathbb{N}$ .

- $\bigcap_{m=0}^{\infty} D(\bar{J}^m) = \mathcal{S}$ .

By (4.1.1) and (4.1.2), we get  $\phi_k = p_k e^{-sx^2/2}$ , where  $p_k$  is the sequence of polynomials inductively given by  $p_0 = s^{(2\sigma+1)/4} \Gamma(\sigma + \frac{1}{2})^{-\frac{1}{2}}$  and

$$p_k = \begin{cases} (2ks)^{-\frac{1}{2}}(2sxp_{k-1} - Tp_{k-1}) & \text{if } k \text{ is even} \\ (2(k+2\sigma)s)^{-\frac{1}{2}}(2sxp_{k-1} - Tp_{k-1}) & \text{if } k \text{ is odd} \end{cases} \quad (k \geq 1).$$

Up to normalization,  $p_k$  is the sequence of generalized Hermite polynomials [66, p. 380, Problem 25], and  $\phi_k$  is the sequence of generalized Hermite functions. Each  $p_k$  is of degree  $k$ , even/odd if  $k$  is even/odd, and with positive leading coefficient. They satisfy the recursion formula [4, Eq. (13)]

$$p_k = \begin{cases} k^{-\frac{1}{2}}((2s)^{\frac{1}{2}}xp_{k-1} - (k-1+2\sigma)^{\frac{1}{2}}p_{k-2}) & \text{if } k \text{ is even} \\ (k+2\sigma)^{-\frac{1}{2}}((2s)^{\frac{1}{2}}xp_{k-1} - (k-1)^{\frac{1}{2}}p_{k-2}) & \text{if } k \text{ is odd.} \end{cases} \quad (4.1.5)$$

When  $k = 2m + 1$  ( $m \in \mathbb{N}$ ), we have [4, Eq. (14)]

$$x^{-1}p_k = \sum_{i=0}^m (-1)^{m-i} \sqrt{\frac{m! \Gamma(i + \frac{1}{2} + \sigma)s}{i! \Gamma(m + \frac{3}{2} + \sigma)}} p_{2i}. \quad (4.1.6)$$

The Pochhammer symbol could be used to simplify this expression, as well as many other expressions in Sections 4.2 and 4.3. However there are quotients of gamma functions in Sections 4.3 and 4.4 that can not be simplified in this way (see e.g. Proposition 4.3.7). Thus, for the sake of uniformity, we use gamma functions in all quotients of this type.

Let  $j$  be the positive definite symmetric sesquilinear form in  $L^2_{\sigma}$ , with  $D(j) = \mathcal{S}$ , given by  $j(\phi, \psi) = \langle J\phi, \psi \rangle_{\sigma}$ . Like in the case of  $J$ , the subindex  $\sigma$  will be added to the notation  $T, B, B'$  and  $\phi_k$  and  $j$  if necessary. Observe that

$$B_{\sigma} = \begin{cases} B_{\tau} & \text{on } \mathcal{S}_{\text{ev}} \\ B_{\tau} + 2(\sigma - \tau)x^{-1} & \text{on } \mathcal{S}_{\text{odd}}, \end{cases} \quad (4.1.7)$$

$$B'_{\sigma} = \begin{cases} B'_{\tau} & \text{on } \mathcal{S}_{\text{ev}} \\ B'_{\tau} + 2(\tau - \sigma)x^{-1} & \text{on } \mathcal{S}_{\text{odd}}. \end{cases} \quad (4.1.8)$$

The operator  $x : \mathcal{S}_{\text{ev}} \rightarrow \mathcal{S}_{\text{odd}}$  is a homeomorphism [4], which extends to a unitary operator  $x : L^2_{\sigma, \text{ev}} \rightarrow L^2_{\sigma-1, \text{odd}}$ . We get  $x J_{\sigma, \text{ev}} x^{-1} = J_{\sigma-1, \text{odd}}$  because  $x [\frac{d^2}{dx^2}, x^{-1}] = -2 \frac{d}{dx} x^{-1}$ . Thus, even for any  $\tau > -\frac{3}{2}$ , the operator  $J_{\tau, \text{odd}}$  is densely defined in  $L^2_{\tau, \text{odd}}$ , with  $D(J_{\tau, \text{odd}}) = \mathcal{S}_{\text{odd}}$ , and has the same spectral properties as

$J_{\tau+1, ev}$ ; in particular, the eigenvalues of  $\overline{J_{\tau, odd}}$  are  $(2k + 1 + 2\tau)s$  ( $k \in 2\mathbb{N} + 1$ ), and  $\phi_{\tau, k} = x\phi_{\tau+1, k-1}$ .

To prove the results of this chapter, alternative arguments could be given by using the expression of the generalized Hermite polynomials in terms of the Laguerre ones (see e.g. [61, p. 525] or [62, p. 23]). In particular, certain asymptotic estimates of Laguerre functions [28, 51] (see also [8, 52]), yield the following asymptotic estimates of the generalized Hermite functions [3, Section 2.4]: there are some  $C, c > 0$ , depending only on  $\sigma$ , such that

$$|\phi_k(x)x^\sigma| \leq \begin{cases} Cs^{\frac{\bar{\sigma}}{2} + \frac{1}{4}} x^{\bar{\sigma}} \nu^{\frac{\bar{\sigma}}{2} - \frac{1}{4}} & \text{if } 0 < x \leq \sqrt{\frac{1}{s\nu}} \\ Cs^{\frac{1}{4}} \nu^{-\frac{1}{4}} & \text{if } \sqrt{\frac{1}{s\nu}} < x \leq \sqrt{\frac{\nu}{2s}} \\ Cs^{\frac{1}{4}} (\nu^{\frac{1}{3}} + |sx^2 - \nu|)^{-\frac{1}{4}} & \text{if } \sqrt{\frac{\nu}{2s}} < x \leq \sqrt{\frac{3\nu}{2s}} \\ C(sx)^{\frac{1}{2}} e^{-csx^2} & \text{if } \sqrt{\frac{3\nu}{2s}} < x, \end{cases} \quad (4.1.9)$$

where  $\bar{\sigma} = \bar{\sigma}_k = \sigma + \frac{1 - (-1)^k}{2}$  and  $\nu = \nu_k = 2k + 1 + 2\sigma$ , with the proviso that we must take  $\nu = 2$  if  $k = 0$  and  $\sigma < \frac{1}{2}$ .

## 4.2 The sesquilinear form $\mathfrak{t}$

Let  $0 < u < 1$  such that  $\sigma > u - \frac{1}{2}$ . Then  $|x|^{-u}\mathcal{S} \subset L^2_\sigma$ , and therefore a positive definite symmetric sesquilinear form  $\mathfrak{t}$  in  $L^2_\sigma$ , with  $D(\mathfrak{t}) = \mathcal{S}$ , is defined by

$$\mathfrak{t}(\phi, \psi) = \langle |x|^{-u}\phi, |x|^{-u}\psi \rangle_\sigma = \langle \phi, \psi \rangle_{\sigma-u}.$$

The notation  $\mathfrak{t}_\sigma$  may be also used. The goal of this section is to study  $\mathfrak{t}$  and apply it to prove Theorem 1.10.1. Precisely, an estimation of the values  $\mathfrak{t}(\phi_k, \phi_\ell)$  is needed.

**Lemma 4.2.1.** *For all  $\phi \in \mathcal{S}_{\text{odd}}$  and  $\psi \in \mathcal{S}_{\text{ev}}$ ,*

$$\mathfrak{t}(B'\phi, \psi) - \mathfrak{t}(\phi, B\psi) = \mathfrak{t}(\phi, B'\psi) - \mathfrak{t}(B\phi, \psi) = -2u \mathfrak{t}(x^{-1}\phi, \psi).$$

*Proof.* By (4.1.7) and (4.1.8), for all  $\phi \in \mathcal{S}_{\text{odd}}$  and  $\psi \in \mathcal{S}_{\text{ev}}$ ,

$$\begin{aligned} &\mathfrak{t}(B'_\sigma\phi, \psi) - \mathfrak{t}(\phi, B_\sigma\psi) \\ &= \langle B'_{\sigma-u}\phi, \psi \rangle_{\sigma-u} - 2u \langle x^{-1}\phi, \psi \rangle_{\sigma-u} - \langle \phi, B_{\sigma-u}\psi \rangle_{\sigma-u} \\ &= -2u \mathfrak{t}(x^{-1}\phi, \psi), \\ &\mathfrak{t}(\phi, B'_\sigma\psi) - \mathfrak{t}(B_\sigma\phi, \psi) \\ &= \langle \phi, B'_{\sigma-u}\psi \rangle_{\sigma-u} - \langle B_{\sigma-u}\phi, \psi \rangle_{\sigma-u} - 2u \langle x^{-1}\phi, \psi \rangle_{\sigma-u} \\ &= -2u \mathfrak{t}(x^{-1}\phi, \psi). \quad \square \end{aligned}$$

In the whole of this section,  $k, \ell, m, n, i, j, p$  and  $q$  will be natural numbers. Let  $c_{k,\ell} = t(\phi_k, \phi_\ell)$  and  $d_{k,\ell} = c_{k,\ell}/c_{0,0}$ . Thus  $d_{k,\ell} = d_{\ell,k}$ , and  $d_{k,\ell} = 0$  when  $k + \ell$  is odd. Since

$$\int_{-\infty}^{\infty} e^{-sx^2} |x|^{2\kappa} dx = s^{-(2\kappa+1)/2} \Gamma(\kappa + \frac{1}{2}) \quad (4.2.1)$$

for  $\kappa > -\frac{1}{2}$ , we get

$$c_{0,0} = \Gamma(\sigma - u + \frac{1}{2}) \Gamma(\sigma + \frac{1}{2})^{-1} s^u. \quad (4.2.2)$$

**Lemma 4.2.2.** *If  $k = 2m > 0$ , then*

$$d_{k,0} = \frac{u}{\sqrt{m}} \sum_{j=0}^{m-1} (-1)^{m-j} \sqrt{\frac{(m-1)! \Gamma(j + \frac{1}{2} + \sigma)}{j! \Gamma(m + \frac{1}{2} + \sigma)}} d_{2j,0}.$$

*Proof.* By (4.1.2), (4.1.3), (4.1.6) and Lemma 4.2.1,

$$\begin{aligned} c_{k,0} &= \frac{1}{\sqrt{2sk}} t(B' \phi_{k-1}, \phi_0) \\ &= \frac{1}{\sqrt{2sk}} t(\phi_{k-1}, B\phi_0) - \frac{2u}{\sqrt{2sk}} t(x^{-1} \phi_{k-1}, \phi_0) \\ &= -\frac{2u}{\sqrt{2sk}} t(x^{-1} \phi_{k-1}, \phi_0) \\ &= \frac{u}{\sqrt{m}} \sum_{j=0}^{m-1} (-1)^{m-j} \sqrt{\frac{(m-1)! \Gamma(j + \frac{1}{2} + \sigma)}{j! \Gamma(m + \frac{1}{2} + \sigma)}} c_{2j,0}. \quad \square \end{aligned}$$

**Lemma 4.2.3.** *If  $k = 2m > 0$  and  $\ell = 2n > 0$ , then*

$$d_{k,\ell} = \sqrt{\frac{m}{n}} d_{k-1,\ell-1} + \frac{u}{\sqrt{n}} \sum_{j=0}^{n-1} (-1)^{n-j} \sqrt{\frac{(n-1)! \Gamma(j + \frac{1}{2} + \sigma)}{j! \Gamma(n + \frac{1}{2} + \sigma)}} d_{k,2j}.$$

*Proof.* By (4.1.2), (4.1.4), (4.1.6) and Lemma 4.2.1,

$$\begin{aligned} c_{k,\ell} &= \frac{1}{\sqrt{2s\ell}} t(\phi_k, B' \phi_{\ell-1}) \\ &= \frac{1}{\sqrt{2\ell s}} t(B\phi_k, \phi_{\ell-1}) - \frac{2u}{\sqrt{2\ell s}} t(\phi_k, x^{-1} \phi_{\ell-1}) \\ &= \sqrt{\frac{m}{n}} c_{k-1,\ell-1} + \frac{u}{\sqrt{n}} \sum_{j=0}^{n-1} (-1)^{n-j} \sqrt{\frac{(n-1)! \Gamma(j + \frac{1}{2} + \sigma)}{j! \Gamma(n + \frac{1}{2} + \sigma)}} c_{k,2j}. \quad \square \end{aligned}$$

**Lemma 4.2.4.** *If  $k = 2m + 1$  and  $\ell = 2n + 1$ , then  $d_{k,\ell}$  is equal to*

$$\sqrt{\frac{n + \frac{1}{2} + \sigma}{m + \frac{1}{2} + \sigma}} d_{k-1,\ell-1} - \frac{u}{\sqrt{m + \frac{1}{2} + \sigma}} \sum_{j=0}^n (-1)^{n-j} \sqrt{\frac{n! \Gamma(j + \frac{1}{2} + \sigma)}{j! \Gamma(n + \frac{3}{2} + \sigma)}} d_{k-1,2j}.$$

*Proof.* By (4.1.2), (4.1.4), (4.1.6) and Lemma 4.2.1,

$$\begin{aligned} c_{k,\ell} &= \frac{1}{\sqrt{2(k+2\sigma)s}} \mathfrak{t}(B' \phi_{k-1}, \phi_\ell) \\ &= \frac{1}{\sqrt{2(k+2\sigma)s}} \mathfrak{t}(\phi_{k-1}, B \phi_\ell) - \frac{2u}{\sqrt{2(k+2\sigma)s}} \mathfrak{t}(\phi_{k-1}, x^{-1} \phi_\ell) \\ &= \sqrt{\frac{n + \frac{1}{2} + \sigma}{m + \frac{1}{2} + \sigma}} c_{k-1,\ell-1} \\ &\quad - \frac{u}{\sqrt{m + \frac{1}{2} + \sigma}} \sum_{j=0}^n (-1)^{n-j} \sqrt{\frac{n! \Gamma(j + \frac{1}{2} + \sigma)}{j! \Gamma(n + \frac{3}{2} + \sigma)}} c_{k-1,2j}. \quad \square \end{aligned}$$

The following definitions are given for  $k \geq \ell$  with  $k + \ell$  even. Let

$$\Pi_{k,\ell} = \sqrt{\frac{m! \Gamma(n + \frac{1}{2} + \sigma)}{n! \Gamma(m + \frac{1}{2} + \sigma)}} \tag{4.2.3}$$

if  $k = 2m \geq \ell = 2n$ , and

$$\Pi_{k,\ell} = \sqrt{\frac{m! \Gamma(n + \frac{3}{2} + \sigma)}{n! \Gamma(m + \frac{3}{2} + \sigma)}} \tag{4.2.4}$$

if  $k = 2m + 1 \geq \ell = 2n + 1$ . Let  $\Sigma_{k,\ell}$  be inductively defined as follows<sup>2</sup>:

$$\Sigma_{k,0} = \prod_{i=1}^m \left(1 - \frac{1-u}{i}\right) = \frac{\Gamma(m+u)}{m! \Gamma(u)} \tag{4.2.5}$$

if  $k = 2m$ ;

$$\Sigma_{k,\ell} = \Sigma_{k-1,\ell-1} + u \sum_{j=0}^{n-1} \frac{(n-1)! \Gamma(j + \frac{1}{2} + \sigma)}{j! \Gamma(n + \frac{1}{2} + \sigma)} \Sigma_{k,2j} \tag{4.2.6}$$

---

<sup>2</sup>We use the convention that a product of an empty set of factors is 1. Empty products are possible in (4.2.5) (when  $m = 0$ ), in Lemma 4.2.10 and its proof, and in the proofs of Lemma 4.2.11 and Remark 4.2.19. Consistently, the sum of an empty set of terms is 0. Empty sums are possible in Lemma 4.3.4 and its proof, and in the proof of Proposition 4.3.7.

if  $k = 2m \geq \ell = 2n > 0$ ; and

$$\Sigma_{k,\ell} = \Sigma_{k-1,\ell-1} - u \sum_{j=0}^n \frac{n! \Gamma(j + \frac{1}{2} + \sigma)}{j! \Gamma(n + \frac{3}{2} + \sigma)} \Sigma_{k-1,2j} \quad (4.2.7)$$

$$= \left(1 - \frac{u}{n + \frac{1}{2} + \sigma}\right) \Sigma_{k-1,\ell-1} - \frac{nu}{n + \frac{1}{2} + \sigma} \sum_{j=0}^{n-1} \frac{(n-1)! \Gamma(j + \frac{1}{2} + \sigma)}{j! \Gamma(n + \frac{1}{2} + \sigma)} \Sigma_{k-1,2j} \quad (4.2.8)$$

if  $k = 2m + 1 \geq \ell = 2n + 1$ . Thus  $\Sigma_{0,0} = 1$ ,  $\Sigma_{2,0} = u$ ,  $\Sigma_{4,0} = \frac{1}{2}u(1 + u)$ , and

$$\Sigma_{k,1} = \left(1 - \frac{u}{\frac{1}{2} + \sigma}\right) \Sigma_{k-1,0} \quad (4.2.9)$$

if  $k$  is odd. From (4.2.5) and using induction on  $m$ , it easily follows that

$$\Sigma_{k,0} = \frac{u}{m} \sum_{j=0}^{m-1} \Sigma_{2j,0} \quad (4.2.10)$$

for  $k = 2m > 0$ . Combining (4.2.6) with (4.2.7), and (4.2.8) with (4.2.6), we get

$$\Sigma_{k,\ell} = \Sigma_{k-2,\ell-2} - u \sum_{j=0}^{n-1} \frac{(n-1)! \Gamma(j + \frac{1}{2} + \sigma)}{j! \Gamma(n + \frac{1}{2} + \sigma)} (\Sigma_{k-2,2j} - \Sigma_{k,2j}) \quad (4.2.11)$$

if  $k = 2m \geq \ell = 2n > 0$ ; and

$$\Sigma_{k,\ell} = \left(1 - \frac{u}{n + \frac{1}{2} + \sigma}\right) \Sigma_{k-2,\ell-2} \quad (4.2.12)$$

$$+ \left(1 - \frac{u+n}{n + \frac{1}{2} + \sigma}\right) u \sum_{j=0}^{n-1} \frac{(n-1)! \Gamma(j + \frac{1}{2} + \sigma)}{j! \Gamma(n + \frac{1}{2} + \sigma)} \Sigma_{k-1,2j} \quad (4.2.13)$$

if  $k = 2m + 1 \geq \ell = 2n + 1 > 1$ .

**Proposition 4.2.5.** We have  $d_{k,\ell} = (-1)^{m+n} \Pi_{k,\ell} \Sigma_{k,\ell}$  if  $k = 2m \geq \ell = 2n$ , or if  $k = 2m + 1 \geq \ell = 2n + 1$ .

*Proof.* We proceed by induction on  $k$  and  $l$ . The statement is obvious for  $k = \ell = 0$  because  $d_{0,0} = \Pi_{0,0} = \Sigma_{0,0} = 1$ .

Let  $k = 2m > 0$ , and assume that the result is true for all  $d_{2j,0}$  with  $j < m$ . Then, by Lemma 4.2.2, (4.2.3) and (4.2.10),

$$\begin{aligned} d_{k,0} &= \frac{u}{\sqrt{m}} \sum_{j=0}^{m-1} (-1)^{m-j} \sqrt{\frac{(m-1)! \Gamma(j + \frac{1}{2} + \sigma)}{j! \Gamma(m + \frac{1}{2} + \sigma)}} (-1)^j \Pi_{2j,0} \Sigma_{2j,0} \\ &= (-1)^m \frac{u}{\sqrt{m}} \sum_{j=0}^{m-1} \sqrt{\frac{(m-1)! \Gamma(j + \frac{1}{2} + \sigma)}{j! \Gamma(m + \frac{1}{2} + \sigma)}} \sqrt{\frac{j! \Gamma(\frac{1}{2} + \sigma)}{\Gamma(j + \frac{1}{2} + \sigma)}} \Sigma_{2j,0} \\ &= (-1)^m \Pi_{k,0} \frac{u}{m} \sum_{j=0}^{m-1} \Sigma_{2j,0} = (-1)^m \Pi_{k,0} \Sigma_{k,0}. \end{aligned}$$

Now, take  $k = 2m \geq \ell = 2n > 0$  so that the equality of the statement holds for  $d_{k-1,\ell-1}$  and all  $d_{k,2j}$  with  $j < n$ . Then, by Lemma 4.2.3,

$$\begin{aligned} d_{k,\ell} &= \sqrt{\frac{m}{n}} (-1)^{m+n} \Pi_{k-1,\ell-1} \Sigma_{k-1,\ell-1} \\ &\quad + \frac{u}{\sqrt{n}} \sum_{j=0}^{n-1} (-1)^{n-j} \sqrt{\frac{(n-1)! \Gamma(j + \frac{1}{2} + \sigma)}{j! \Gamma(n + \frac{1}{2} + \sigma)}} (-1)^{m+j} \Pi_{k,2j} \Sigma_{k,2j}. \end{aligned}$$

Here, by (4.2.3) and (4.2.4),  $\sqrt{m/n} \Pi_{k-1,\ell-1} = \Pi_{k,\ell}$ , and

$$\begin{aligned} \frac{1}{\sqrt{n}} \sqrt{\frac{(n-1)! \Gamma(j + \frac{1}{2} + \sigma)}{j! \Gamma(n + \frac{1}{2} + \sigma)}} \Pi_{k,2j} \\ = \frac{1}{\sqrt{n}} \sqrt{\frac{m! \Gamma(n + \frac{1}{2} + \sigma)}{(n-1)! \Gamma(m + \frac{1}{2} + \sigma)}} \frac{(n-1)! \Gamma(j + \frac{1}{2} + \sigma)}{j! \Gamma(n + \frac{1}{2} + \sigma)} \\ = \Pi_{k,\ell} \frac{(n-1)! \Gamma(j + \frac{1}{2} + \sigma)}{j! \Gamma(n + \frac{1}{2} + \sigma)}. \end{aligned}$$

Thus, by (4.2.6),  $d_{k,\ell} = (-1)^{m+n} \Pi_{k,\ell} \Sigma_{k,\ell}$ .

Finally, take  $k = 2m + 1 \geq \ell = 2n + 1$  such that the equality of the statement holds for all  $d_{k-1,2j}$  with  $j \leq n$ . Then, by Lemma 4.2.4,

$$\begin{aligned} d_{k,\ell} &= \sqrt{\frac{n + \frac{1}{2} + \sigma}{m + \frac{1}{2} + \sigma}} (-1)^{m+n} \Pi_{k-1,\ell-1} \Sigma_{k-1,\ell-1} \\ &\quad - \frac{u}{\sqrt{m + \frac{1}{2} + \sigma}} \sum_{j=0}^n (-1)^{n-j} \sqrt{\frac{n! \Gamma(j + \frac{1}{2} + \sigma)}{j! \Gamma(n + \frac{3}{2} + \sigma)}} (-1)^{m+j} \Pi_{k-1,2j} \Sigma_{k-1,2j}. \end{aligned}$$

Here, by (4.2.3) and (4.2.4),

$$\sqrt{\frac{n + \frac{1}{2} + \sigma}{m + \frac{1}{2} + \sigma}} \Pi_{k-1, \ell-1} = \Pi_{k, \ell},$$

and

$$\begin{aligned} & \frac{1}{\sqrt{m + \frac{1}{2} + \sigma}} \sqrt{\frac{n! \Gamma(j + \frac{1}{2} + \sigma)}{j! \Gamma(n + \frac{3}{2} + \sigma)}} \Pi_{k-1, 2j} \\ &= \frac{1}{\sqrt{m + \frac{1}{2} + \sigma}} \sqrt{\frac{m! \Gamma(n + \frac{3}{2} + \sigma)}{n! \Gamma(m + \frac{1}{2} + \sigma)}} \frac{n! \Gamma(j + \frac{1}{2} + \sigma)}{j! \Gamma(n + \frac{3}{2} + \sigma)} \\ &= \Pi_{k, \ell} \frac{n! \Gamma(j + \frac{1}{2} + \sigma)}{j! \Gamma(n + \frac{3}{2} + \sigma)}. \end{aligned}$$

Thus, by (4.2.7),  $d_{k, \ell} = (-1)^{m+n} \Pi_{k, \ell} \Sigma_{k, \ell}$ . □

**Lemma 4.2.6.**  $\Sigma_{k, \ell} > 0$  for all  $k$  and  $\ell$ .

*Proof.* We proceed by induction on  $\ell$ . For  $\ell \in \{0, 1\}$ , this is true by (4.2.5) and (4.2.9) because  $\sigma > u - \frac{1}{2}$ . If  $\ell > 1$  and the result holds for  $\Sigma_{k', \ell'}$  with  $\ell' < \ell$ , then  $\Sigma_{k, \ell} > 0$  by (4.2.6) and (4.2.12) since  $\sigma > u - \frac{1}{2}$ . □

**Lemma 4.2.7.** If  $k = 2m > \ell = 2n$  or  $k = 2m + 1 > \ell = 2n + 1$ , then

$$\Sigma_{k, \ell} \leq \left(1 - \frac{1-u}{m}\right) \Sigma_{k-2, \ell}.$$

*Proof.* We proceed by induction on  $\ell$ . This is true for  $\ell \in \{0, 1\}$  by (4.2.5) and (4.2.9).

Now, suppose that the result is satisfied by  $\Sigma_{k', \ell'}$  with  $\ell' < \ell$ . If  $k = 2m > \ell = 2n > 0$ , then, by (4.2.6) and Lemma 4.2.6,

$$\begin{aligned} \Sigma_{k, \ell} &\leq \left(1 - \frac{1-u}{m-1}\right) \Sigma_{k-3, \ell-1} \\ &\quad + u \sum_{j=0}^{n-1} \frac{(n-1)! \Gamma(j + \frac{1}{2} + \sigma)}{j! \Gamma(n + \frac{1}{2} + \sigma)} \left(1 - \frac{1-u}{m}\right) \Sigma_{k-2, 2j} \\ &\leq \left(1 - \frac{1-u}{m}\right) \Sigma_{k-2, \ell}. \end{aligned}$$

If  $k = 2m + 1 > \ell = 2n + 1 > 1$ , then, by (4.2.12) and Lemma 4.2.6, and since  $\sigma > u - \frac{1}{2}$ ,

$$\begin{aligned} \Sigma_{k,\ell} &\leq \left(1 - \frac{u}{n + \frac{1}{2} + \sigma}\right) \left(1 - \frac{1-u}{m-1}\right) \Sigma_{k-4,\ell-2} \\ &\quad + \left(1 - \frac{u+n}{n + \frac{1}{2} + \sigma}\right) u \sum_{j=0}^{n-1} \frac{(n-1)! \Gamma(j + \frac{1}{2} + \sigma)}{j! \Gamma(n + \frac{1}{2} + \sigma)} \left(1 - \frac{1-u}{m}\right) \Sigma_{k-3,2j} \\ &< \left(1 - \frac{1-u}{m}\right) \Sigma_{k-2,\ell}. \quad \square \end{aligned}$$

**Corollary 4.2.8.** *If  $k = 2m \geq \ell = 2n > 0$ , then*

$$\Sigma_{k-1,\ell-1} < \Sigma_{k,\ell} \leq \left(1 - \frac{u(1-u)}{m}\right) \Sigma_{k-2,\ell-2}.$$

*Proof.* The first inequality is a direct consequence of (4.2.6), and Lemma 4.2.6. On the other hand, by (4.2.11), and Lemmas 4.2.6 and 4.2.7,

$$\begin{aligned} \Sigma_{k,\ell} &\leq \Sigma_{k-2,\ell-2} - \frac{u(1-u)}{m} \sum_{j=0}^{n-1} \frac{(n-1)! \Gamma(j + \frac{1}{2} + \sigma)}{j! \Gamma(n + \frac{1}{2} + \sigma)} \Sigma_{k-2,2j} \\ &= \left(1 - \frac{u(1-u)}{m}\right) \Sigma_{k-2,\ell-2} - \frac{u(1-u)}{m} \sum_{j=0}^{n-2} \frac{(n-1)! \Gamma(j + \frac{1}{2} + \sigma)}{j! \Gamma(n + \frac{1}{2} + \sigma)} \Sigma_{k-2,2j} \\ &\leq \left(1 - \frac{u(1-u)}{m}\right) \Sigma_{k-2,\ell-2}. \quad \square \end{aligned}$$

**Corollary 4.2.9.** *If  $k = 2m + 1 \geq \ell = 2n + 1$ , then*

$$\left(1 - \frac{u}{n + \frac{1}{2} + \sigma}\right) \Sigma_{k-2,\ell-2} < \Sigma_{k,\ell} \leq \left(1 - \frac{u}{n + \frac{1}{2} + \sigma}\right) \Sigma_{k-1,\ell-1}.$$

*Proof.* This follows from (4.2.8), (4.2.12) and Lemma 4.2.6 because  $\sigma > u - \frac{1}{2}$ .  $\square$

**Lemma 4.2.10.** *For  $0 < t < 1$ , there is some  $C_0 = C_0(t) \geq 1$  such that, for all  $p$ ,*

$$C_0^{-1}(p+1)^{-t} \leq \prod_{i=1}^p \left(1 - \frac{t}{i}\right) \leq C_0(p+1)^{-t}.$$

*Proof.* For each  $t > 0$ , by the Weierstrass definition of the gamma function,

$$\Gamma(t) = \frac{e^{-\gamma t}}{t} \prod_{i=1}^{\infty} \left(1 + \frac{t}{i}\right)^{-1} e^{t/i},$$

where  $\gamma = \lim_{j \rightarrow \infty} (\sum_{i=1}^j \frac{1}{i} - \ln j)$  (the Euler-Mascheroni constant), there is some  $K_0 \geq 1$  such that, for all  $p \in \mathbb{Z}_+$ ,

$$K_0^{-1} \prod_{i=1}^p e^{-t/i} \leq \prod_{i=1}^p \left(1 + \frac{t}{i}\right)^{-1} \leq K_0 \prod_{i=1}^p e^{-t/i}. \quad (4.2.14)$$

Now, assume that  $0 < t < 1$ , and observe that

$$\prod_{i=1}^p \left(1 - \frac{t}{i}\right) = \prod_{i=1}^p \left(1 + \frac{t}{i-t}\right)^{-1}.$$

By the second inequality of (4.2.14), for  $p \geq 1$ ,

$$\begin{aligned} \prod_{i=1}^p \left(1 + \frac{t}{i-t}\right)^{-1} &< \prod_{i=1}^p \left(1 + \frac{t}{i}\right)^{-1} \leq K_0 \prod_{i=1}^p e^{-t/i} \\ &= K_0 \exp\left(-t \sum_{i=1}^p \frac{1}{i}\right) \leq K_0 \exp\left(-t \int_1^{p+1} \frac{dx}{x}\right) = K_0(p+1)^{-t}. \end{aligned}$$

On the other hand, by the first inequality of (4.2.14), for  $p \geq 2$ ,

$$\begin{aligned} \prod_{i=1}^p \left(1 + \frac{t}{i-t}\right)^{-1} &\geq (1-t) \prod_{i=1}^{p-1} \left(1 + \frac{t}{i}\right)^{-1} \geq (1-t) K_0^{-1} \prod_{i=1}^{p-1} e^{-t/i} \\ &= (1-t) K_0^{-1} \exp\left(-t \sum_{i=1}^{p-1} \frac{1}{i}\right) \geq (1-t) K_0^{-1} \exp\left(-t \left(1 + \int_1^{p-1} \frac{dx}{x}\right)\right) \\ &= (1-t) K_0^{-1} e^{-t} (p-1)^{-t} > (1-t) K_0^{-1} e^{-t} (p+1)^{-t}. \quad \square \end{aligned}$$

**Lemma 4.2.11.** *There is some  $C' = C'(u) > 0$  such that*

$$\Sigma_{k,\ell} \leq C'(m+1)^{-u(1-u)} (m-n+1)^{-(1-u)^2}$$

for  $k = 2m \geq \ell = 2n$  or  $k = 2m+1 \geq \ell = 2n+1$ .

*Proof.* Suppose first that  $k = 2m \geq \ell = 2n$ . By Lemma 4.2.7 and Corollary 4.2.8, we get

$$\begin{aligned} \Sigma_{k,\ell} &\leq \prod_{i=m-n+1}^m \left(1 - \frac{u(1-u)}{i}\right) \prod_{i=1}^{m-n} \left(1 - \frac{1-u}{i}\right) \\ &= \prod_{i=1}^m \left(1 - \frac{u(1-u)}{i}\right) \prod_{i=1}^{m-n} \left(1 - \frac{u(1-u)}{i}\right)^{-1} \prod_{i=1}^{m-n} \left(1 - \frac{1-u}{i}\right). \end{aligned}$$

Then the result follows in this case from Lemma 4.2.10.

When  $k = 2m + 1 \geq \ell = 2n + 1$ , the result follows from the above case and Corollary 4.2.9.  $\square$

**Lemma 4.2.12.** *For each  $t \in \mathbb{R} \setminus (-\mathbb{N})$ , there is some  $C_1 = C_1(t) \geq 1$  such that, for all  $p$ ,*

$$C_1^{-1}(p+1)^{1-t} \leq \frac{\Gamma(p+1)}{|\Gamma(p+t)|} \leq C_1(p+1)^{1-t}.$$

*Proof.* We can assume that  $p \geq 1$ . Write  $t = q + r$ , where  $q = \lfloor t \rfloor$ . If  $q = 0$ , then  $0 < r < 1$  and the result follows from the Gautschi's inequality, stating that

$$x^{1-r} \leq \frac{\Gamma(x+1)}{\Gamma(x+r)} \leq (x+1)^{1-r} \tag{4.2.15}$$

for  $0 < r < 1$  and  $x > 0$ , because  $x^{1-r} \geq 2^{r-1}(x+1)^{1-r}$  for  $x \geq 1$ .

If  $q \geq 1$  and  $r = 0$ , then

$$\begin{aligned} \frac{\Gamma(p+1)}{\Gamma(p+t)} &= \frac{p!}{(p+q-1)!} \leq \frac{1}{(p+1)^{q-1}} = (p+1)^{1-t}, \\ \frac{\Gamma(p+1)}{\Gamma(p+t)} &= \frac{p!}{(p+q-1)!} \geq \frac{1}{(p+q-1)^{q-1}} \geq \frac{1}{(qp)^{q-1}} \\ &\geq t^{1-t}(p+1)^{1-t}. \end{aligned}$$

If  $q \geq 1$  and  $r > 0$ , then, by (4.2.15),

$$\begin{aligned} \frac{\Gamma(p+1)}{\Gamma(p+t)} &\leq \frac{\Gamma(p+1)}{(p+1)^{q-1}(p+r)\Gamma(p+r)} \leq \frac{(p+1)^{2-q-r}}{p+r} \leq 2(p+1)^{1-t}, \\ \frac{\Gamma(p+1)}{\Gamma(p+t)} &\geq \frac{\Gamma(p+1)}{(p+t-1)^q\Gamma(p+r)} \geq \frac{p^{1-r}}{(p+t-1)^q} \geq \frac{(p+1)^{1-r}}{2^{1-r}(p+t-1)^q} \\ &\geq \min\{1, (t-1)^{-q}\} 2^{r-1}(p+1)^{1-t}, \end{aligned}$$

because

$$(p+t-1)^{-q} \geq \begin{cases} (p+1)^{-q} & \text{if } 0 < t \leq 2 \\ (t-1)^{-q}(p+1)^{-q} & \text{if } t > 2. \end{cases}$$

In the case  $q < 0$  ( $t < 0$ ), apply reverse induction on  $q$ : with  $C_1 = C_1(t+1)$ , we get

$$\begin{aligned} \frac{\Gamma(p+1)}{|\Gamma(p+t)|} &= \frac{|p+t|\Gamma(p+1)}{|\Gamma(p+t+1)|} \leq |p+t|C_1(p+1)^{-t} \leq C_1|q|(p+1)^{1-t}, \\ \frac{\Gamma(p+1)}{|\Gamma(p+t)|} &= \frac{|p+t|\Gamma(p+1)}{|\Gamma(p+t+1)|} \geq |p+t|C_1^{-1}(p+1)^{-t} \\ &= \frac{|p+t|}{p+1}C_1^{-1}(p+1)^{1-t}, \end{aligned}$$

where  $|p + t|/(p + 1)$  is bounded uniformly on  $p$ .  $\square$

**Corollary 4.2.13.** *There is some  $C'' = C''(\sigma) > 0$  such that*

$$\Pi_{k,\ell} \leq \begin{cases} C'' \left(\frac{n+1}{m+1}\right)^{\frac{\sigma}{2}-\frac{1}{4}} & \text{if } k = 2m \geq \ell = 2n \\ C'' \left(\frac{n+1}{m+1}\right)^{\frac{\sigma}{2}+\frac{1}{4}} & \text{if } k = 2m + 1 \geq \ell = 2n + 1. \end{cases}$$

*Proof.* This follows from (4.2.3), (4.2.4) and Lemma 4.2.12.  $\square$

For the sake of simplicity, let us use the following notation. For real valued functions  $f$  and  $g$  of  $(m, n)$ , for  $(m, n)$  in some subset of  $\mathbb{N} \times \mathbb{N}$ , write  $f \preccurlyeq g$  if there is some  $C > 0$  such that  $f(m, n) \leq Cg(m, n)$  for all  $(m, n)$ . The same notation is used for functions depending also on other variables,  $s, \sigma, u, \dots$ , taking  $C$  independent of  $m, n$  and  $s$ , but possibly depending on the rest of variables.

**Lemma 4.2.14.** *For  $\alpha, \beta, \gamma \in \mathbb{R}$ , if  $\alpha + \beta, \alpha + \gamma, \alpha + \beta + \gamma < 0$ , then there is some  $\omega > 0$  such that, for all naturals  $m \geq n$ ,*

$$(m + 1)^\alpha (n + 1)^\beta (m - n + 1)^\gamma \preccurlyeq (m + 1)^{-\omega} (n + 1)^{-\omega}.$$

*Proof.* We consider the following cases:

1. If  $\alpha, \beta, \gamma < 0$ , then

$$(m + 1)^\alpha (n + 1)^\beta (m - n + 1)^\gamma \leq (m + 1)^\alpha (n + 1)^\beta.$$

2. If  $\beta \geq 0$  and  $\gamma < 0$ , then

$$\begin{aligned} (m + 1)^\alpha (n + 1)^\beta (m - n + 1)^\gamma &\leq (m + 1)^{\alpha+\beta} \\ &\leq (m + 1)^{\frac{\alpha+\beta}{2}} (n + 1)^{\frac{\alpha+\beta}{2}}. \end{aligned}$$

3. If  $\alpha \geq 0$  and  $m + 1 \leq 2(n + 1)$ , then  $\beta, \gamma < 0$  and

$$\begin{aligned} (m + 1)^\alpha (n + 1)^\beta (m - n + 1)^\gamma &\leq 2^{-\beta} (m + 1)^{\alpha+\beta} \\ &\leq 2^{-\beta} (m + 1)^{\frac{\alpha+\beta}{2}} (n + 1)^{\frac{\alpha+\beta}{2}}. \end{aligned}$$

4. If  $\alpha \geq 0$  and  $m + 1 > 2(n + 1)$ , then  $\beta, \gamma < 0$  and  $m - n + 1 > (m + 1)/2$ , and therefore

$$(m + 1)^\alpha (n + 1)^\beta (m - n + 1)^\gamma \leq 2^{-\gamma} (m + 1)^{\alpha+\gamma} (n + 1)^\beta.$$

5. If  $\beta < 0$  and  $\gamma \geq 0$ , then

$$(m+1)^\alpha(n+1)^\beta(m-n+1)^\gamma \leq (m+1)^{\alpha+\gamma}(n+1)^\beta.$$

6. If  $\beta \geq 0$  and  $\gamma \geq 0$ , then

$$\begin{aligned} (m+1)^\alpha(n+1)^\beta(m-n+1)^\gamma &\leq (m+1)^{\alpha+\beta+\gamma} \\ &\leq (m+1)^{\frac{\alpha+\beta+\gamma}{2}}(n+1)^{\frac{\alpha+\beta+\gamma}{2}}. \quad \square \end{aligned}$$

**Proposition 4.2.15.** *There is some  $\omega = \omega(\sigma, u) > 0$  such that*

$$|d_{k,\ell}| \preccurlyeq (m+1)^{-\omega}(n+1)^{-\omega}$$

for  $k = 2m$  and  $\ell = 2n$ , or for  $k = 2m + 1$  and  $\ell = 2n + 1$ .

*Proof.* We can assume  $k \geq \ell$  because  $d_{k,\ell} = d_{\ell,k}$ .

If  $k = 2m + 1 \geq \ell = 2n + 1$ , then, according to Proposition 4.2.5, Lemma 4.2.11 and Corollary 4.2.13,

$$|d_{k,\ell}| \preccurlyeq (m+1)^{-\frac{\sigma}{2}-\frac{1}{4}-u(1-u)}(n+1)^{\frac{\sigma}{2}+\frac{1}{4}}(m-n+1)^{-(1-u)^2}.$$

Thus the result follows by Lemma 4.2.14 since

$$-\frac{\sigma}{2} - \frac{1}{4} - u(1-u) - (1-u)^2 = -\frac{\sigma}{2} + u - \frac{5}{4} < \frac{u}{2} - 1 < 0.$$

If  $k = 2m \geq \ell = 2n$ , then, according to Proposition 4.2.5, Lemma 4.2.11 and Corollary 4.2.13,

$$|d_{k,\ell}| \preccurlyeq (m+1)^{-\frac{\sigma}{2}+\frac{1}{4}-u(1-u)}(n+1)^{\frac{\sigma}{2}-\frac{1}{4}}(m-n+1)^{-(1-u)^2}.$$

Thus the result follows by Lemma 4.2.14 since

$$-\frac{\sigma}{2} + \frac{1}{4} - u(1-u) - (1-u)^2 = -\frac{\sigma}{2} + u - \frac{3}{4} < \frac{u}{2} - \frac{1}{2} < 0. \quad \square$$

**Corollary 4.2.16.** *There is some  $\omega = \omega(\sigma, u) > 0$  such that, for  $k = 2m$  and  $\ell = 2n$ , or for  $k = 2m + 1$  and  $\ell = 2n + 1$ ,*

$$|c_{k,\ell}| \preccurlyeq s^u(m+1)^{-\omega}(n+1)^{-\omega}.$$

*Proof.* This follows from Proposition 4.2.15 and (4.2.2). □

**Proposition 4.2.17.** *For any  $\epsilon > 0$ , there is some  $C = C(\epsilon, \sigma, u) > 0$  such that, for all  $\phi \in \mathcal{S}$ ,*

$$\mathfrak{t}(\phi) \leq \epsilon s^{u-1} \mathfrak{j}(\phi) + C s^u \|\phi\|_\sigma^2.$$

*Proof.* For each  $k$ , let  $\nu_k = 2k + 1 + 2\sigma$ . By Corollary 4.2.16, there are some  $K_0 = K_0(\sigma, u) > 0$  and  $\omega = \omega(\sigma, u) > 0$  such that

$$|c_{k,\ell}| \leq K_0 s^u \nu_k^{-\omega} \nu_\ell^{-\omega} \quad (4.2.16)$$

for all  $k$  and  $\ell$ . Since  $S = S(\sigma, u) := \sum_k \nu_k^{-1-2\omega} < \infty$ , given  $\epsilon > 0$ , there is some  $k_0 = k_0(\epsilon, \sigma, u)$  so that

$$S_0 = S_0(\epsilon, \sigma, u) := \sum_{k > k_0} \nu_k^{-1-2\omega} < \frac{\epsilon^2}{4K_0^2 S}.$$

Let  $S_1 = S_1(\epsilon, \sigma, u) = \sum_{k \leq k_0} \nu_k^{-\omega}$ . For  $\phi = \sum_k t_k \phi_k \in \mathcal{S}$ , by (4.2.16) and the Schwartz inequality, we have

$$\begin{aligned} \mathfrak{t}(\phi) &= \sum_{k,\ell} t_k \bar{t}_\ell c_{k,\ell} \leq \sum_{k,\ell} |t_k| |t_\ell| |c_{k,\ell}| \\ &\leq K_0 s^{u-\frac{1}{2}} \sum_{k \leq k_0} \frac{|t_k|}{\nu_k^\omega} \sum_\ell \frac{|t_\ell| (\nu_\ell s)^{\frac{1}{2}}}{\nu_\ell^{\frac{1}{2}+\omega}} \\ &\quad + K_0 s^{u-1} \sum_{k > k_0} \frac{|t_k| (\nu_k s)^{\frac{1}{2}}}{\nu_k^{\frac{1}{2}+\omega}} \sum_\ell \frac{|t_\ell| (\nu_\ell s)^{\frac{1}{2}}}{\nu_\ell^{\frac{1}{2}+\omega}} \\ &\leq K_0 S_1 S^{\frac{1}{2}} s^{u-\frac{1}{2}} \|\phi\|_\sigma \mathfrak{j}(\phi)^{\frac{1}{2}} + K_0 S_0^{\frac{1}{2}} S^{\frac{1}{2}} s^{u-1} \mathfrak{j}(\phi) \\ &\leq K_0 S_1 S^{\frac{1}{2}} s^{u-\frac{1}{2}} \|\phi\|_\sigma \mathfrak{j}(\phi)^{\frac{1}{2}} + \frac{\epsilon s^{u-1}}{2} \mathfrak{j}(\phi) \\ &\leq \frac{K_0^2 S_1^2 S^u}{2\epsilon} \|\phi\|_\sigma^2 + \epsilon s^{u-1} \mathfrak{j}(\phi). \quad \square \end{aligned}$$

**Proposition 4.2.18.** *There is some  $D = D(\sigma, u) > 0$  such that, for all  $k \in \mathbb{N}$  and  $\phi$  in the linear span of  $\phi_0, \dots, \phi_k$ ,*

$$\mathfrak{t}(\phi) \geq D s^u (k+1)^{-u} \|\phi\|_\sigma^2.$$

*Proof.* Let  $\phi = \sum_{i=0}^k t_i \phi_i$  ( $t_i \in \mathbb{C}$ ) and  $\nu = \nu_k = 2k + 1 + 2\sigma$ . Let  $K \geq 3$ , which

will be fixed later. By (4.1.9),

$$\begin{aligned}
 \int_{|x| \geq \sqrt{\frac{K\nu}{2s}}} |\phi(x)|^2 |x|^{2\sigma} dx &= \sum_{i,j=0}^k t_i \bar{t}_j \int_{|x| \geq \sqrt{\frac{K\nu}{2s}}} \phi_i(x) \overline{\phi_j(x)} |x|^{2\sigma} dx \\
 &\leq 2 \sum_{i,j=0}^k |t_i| |t_j| \int_{\sqrt{\frac{K\nu}{2s}}}^{\infty} |\phi_i(x)| |\phi_j(x)| x^{2\sigma} dx \\
 &\leq \sum_{i,j=0}^k (|t_i|^2 + |t_j|^2) C^2 s \int_{\sqrt{\frac{K\nu}{2s}}}^{\infty} x e^{-2csx^2} dx \\
 &= 2(k+1) \|\phi\|_{\sigma}^2 C^2 s \int_{\sqrt{\frac{K\nu}{2s}}}^{\infty} x e^{-2csx^2} dx \\
 &= \frac{C^2(k+1)}{2c} e^{-Kc\nu} \|\phi\|_{\sigma}^2,
 \end{aligned}$$

where  $C, c > 0$  depend only on  $\sigma$ . We can choose some  $K = K(\sigma) \geq 3$  and  $D = D(\sigma, u) > 0$  such that

$$\left(\frac{2s}{K\nu}\right)^u \left(1 - \frac{C^2(k+1)}{2c} e^{-Kc\nu}\right) \geq Ds^u (k+1)^{-u}$$

for all  $s > 0$  and  $k \in \mathbb{N}$ , obtaining

$$\begin{aligned}
 \mathfrak{t}(\phi) &\geq \int_{|x| \leq \sqrt{\frac{K\nu}{2s}}} |\phi(x)|^2 |x|^{2\sigma-2u} dx \\
 &\geq \left(\frac{2s}{K\nu}\right)^u \int_{|x| \leq \sqrt{\frac{K\nu}{2s}}} |\phi(x)|^2 |x|^{2\sigma} dx \\
 &\geq \left(\frac{2s}{K\nu}\right)^u \|\phi\|_{\sigma}^2 \left(1 - \frac{C^2(k+1)}{2c} e^{-Kc\nu}\right) \\
 &\geq Ds^u (k+1)^{-u} \|\phi\|_{\sigma}^2. \quad \square
 \end{aligned}$$

*Remark 4.2.19.* For  $\phi = \phi_k$ , we can also use the following argument. By Proposition 4.2.5 and (4.2.2), and since  $\Pi_{k,k} = 1$ , it is enough to prove that there is some  $D_0 = D_0(\sigma, u) > 0$  so that  $\Sigma_{k,k} \geq D_0 (k+1)^{-u}$ . Moreover we can assume that  $k = 2m+1$  by Corollary 4.2.8. We have  $p_0 := \lfloor \frac{1}{2} + \sigma \rfloor \geq 0$  because  $\frac{1}{2} + \sigma > u$ . According to Corollary 4.2.9, Lemma 4.2.10 and (4.2.9), there is some  $C_0 = C_0(u) \geq 1$

such that

$$\begin{aligned} \Sigma_{k,k} &\geq \prod_{i=0}^m \left(1 - \frac{u}{i + \frac{1}{2} + \sigma}\right) \geq \left(1 - \frac{u}{\frac{1}{2} + \sigma}\right) \prod_{p=1+p_0}^{m+p_0} \left(1 - \frac{u}{p}\right) \\ &= \left(1 - \frac{u}{\frac{1}{2} + \sigma}\right) \prod_{p=1}^{m+p_0} \left(1 - \frac{u}{p}\right) \prod_{p=1}^{p_0} \left(1 - \frac{u}{p}\right)^{-1} \\ &\geq \left(1 - \frac{u}{\frac{1}{2} + \sigma}\right) C_0^{-2} (m + p_0 + 1)^{-u} (p_0 + 1)^u \\ &\geq \left(1 - \frac{u}{\frac{1}{2} + \sigma}\right) C_0^{-2} (k + 1)^{-u}. \end{aligned}$$

*Remark 4.2.20.* If  $0 < u < \frac{1}{2}$ , then  $\lim_m \mathfrak{t}(\phi_{2m+1}) = 0$ . To check it, we use that there is some  $K = K(\sigma, s) > 0$  so that  $|x|^{2\sigma} \phi_k^2(x) \leq K k^{-\frac{1}{6}}$  for all  $x \in \mathbb{R}$  and all odd  $k \in \mathbb{N}$  [3, Theorem 1.1-(ii)] (this also follows from (4.1.9)). For any  $\epsilon > 0$ , take some  $x_0 > 0$  and  $k_0 \in \mathbb{N}$  such that  $x_0^{-2u} < \epsilon/2$  and  $K k_0^{-\frac{1}{6}} x_0^{1-2u} < \epsilon(1 - 2u)/4$ . Then, for all odd natural  $k \geq k_0$ ,

$$\begin{aligned} \mathfrak{t}(\phi_k) &= 2 \int_0^{x_0} \phi_k^2(x) x^{2(\sigma-u)} dx + 2 \int_{x_0}^{\infty} \phi_k^2(x) x^{2(\sigma-u)} dx \\ &\leq 2K k^{-\frac{1}{6}} \int_0^{x_0} x^{-2u} dx + 2x_0^{-2u} \int_{x_0}^{\infty} \phi_k^2(x) x^{2\sigma} dx \\ &\leq 2K k^{-\frac{1}{6}} \frac{x_0^{1-2u}}{1-2u} + x_0^{-2u} < \epsilon \end{aligned}$$

because  $1 - 2u > 0$  and  $\|\phi_k\|_{\sigma} = 1$ . In the case where  $\sigma \geq 0$ , this argument is also valid when  $k$  is even. We do not know if  $\inf_k \mathfrak{t}(\phi_k) > 0$  when  $\frac{1}{2} \leq u < 1$ .

*Proof of Theorem 1.10.1.* The positive definite sesquilinear form  $\mathfrak{j}$  of Section 4.1 is closable by [41, Theorems VI-2.1 and VI-2.7]. Then, taking  $\epsilon > 0$  such that  $\xi \epsilon s^{u-1} < 1$ , it follows from [41, Theorem VI-1.33] and Proposition 4.2.17 that the positive definite sesquilinear form  $\mathfrak{u} := \mathfrak{j} + \xi \mathfrak{t}$  is also closable, and  $D(\bar{\mathfrak{u}}) = D(\bar{\mathfrak{j}})$ . By [41, Theorems VI-2.1, VI-2.6 and VI-2.7], there is a unique positive definite self-adjoint operator  $\mathcal{U}$  such that  $D(\mathcal{U})$  is a core of  $D(\bar{\mathfrak{u}})$ , which consists of the elements  $\phi \in D(\bar{\mathfrak{u}})$  so that, for some  $\chi \in L^2_{\sigma}$ , we have  $\bar{\mathfrak{u}}(\phi, \psi) = \langle \chi, \psi \rangle_{\sigma}$  for all  $\psi$  in some core of  $\bar{\mathfrak{u}}$  (in this case,  $\mathcal{U}(\phi) = \chi$ ). By [41, Theorem VI-2.23], we have  $D(\mathcal{U}^{1/2}) = D(\bar{\mathfrak{u}})$ ,  $\mathcal{S}$  is a core of  $\mathcal{U}^{1/2}$  (since it is a core of  $\mathfrak{u}$ ), and (1.10.1) is satisfied. By Proposition 4.2.18, there is some  $D(\sigma, u)$  so that, for all  $s > 0$  and  $k \in \mathbb{N}$ , and every  $\phi$  is in the linear span of  $\phi_0, \dots, \phi_k$ , we have  $\mathfrak{t}(\phi) \geq D s^u (k + 1)^{-u} \|\phi\|_{\sigma}^2$ . Moreover we

can assume that the sequence  $(2k + 1 + 2\sigma)s + \xi Ds^u(k + 1)^{-u}$  is strictly increasing after reducing  $D$  if necessary. So

$$u(\phi) \geq ((2k + 1 + 2\sigma)s + \xi Ds^u(k + 1)^{-u}) \|\phi\|_\sigma^2$$

if  $\phi \in \mathcal{S}$  is orthogonal in  $L_\sigma^2$  to the linear span of  $\phi_0, \dots, \phi_{k-1}$  (assuming that this span is 0 when  $k = 0$ ). Therefore  $\mathcal{U}$  has a discrete spectrum satisfying (1.10.2) by the form version of the min-max principle [58, Theorem XIII.2]. The inequality (1.10.3) holds because

$$\bar{u}(\phi) \leq (1 + \xi \epsilon s^{u-1}) \bar{j}(\phi) + \xi C s^u \|\phi\|_\sigma^2$$

for all  $\phi \in D(\bar{u})$  by Proposition 4.2.17 and [41, Theorem VI-1.18], since  $\mathcal{S}$  is a core of  $\bar{u}$  and  $\bar{j}$ . □

*Remark 4.2.21.* In the above proof, note that  $\bar{u} = \bar{j} + \xi \bar{l}$  and  $D(\bar{j}) = D(\bar{J}^{1/2})$ . Thus (1.10.1) can be extended to  $\phi, \psi \in D(\mathcal{U}^{1/2})$  using  $\langle \bar{J}^{1/2} \phi, \bar{J}^{1/2} \psi \rangle_\sigma$  instead of  $\langle J\phi, \psi \rangle_\sigma$ .

*Remark 4.2.22.* Extend the definition of the above forms and operators to the case of  $\xi \in \mathbb{C}$ . Then  $|\bar{l}(\phi)| \leq \epsilon s^{u-1} \Re \bar{j}(\phi) + C s^u \|\phi\|_\sigma^2$  for all  $\phi \in D(\bar{j})$ , like in the proof of Theorem 1.10.1. Thus the family  $\bar{u} = \bar{u}(\xi)$  becomes holomorphic of type (a) by Remark 4.2.21 and [41, Theorem VII-4.8], and therefore  $\mathcal{U} = \mathcal{U}(\xi)$  is a self-adjoint holomorphic family of type (B). So the functions  $\lambda_k = \lambda_k(\xi)$  ( $\xi \in \mathbb{R}$ ) are continuous and piecewise holomorphic [41, Remark VII-4.22, Theorem VII-3.9, and VII-§ 3.4], with  $\lambda_k(0) = (2k + 1 + 2\sigma)s$ . Moreover [41, Theorem VII-4.21] gives an exponential estimate of  $|\lambda_k(\xi) - \lambda_k(0)|$  in terms of  $\xi$ . But (1.10.2) and (1.10.3) are a better estimate for the eigenvalues.

### 4.3 Scalar products of mixed generalized Hermite functions

Let  $\sigma, \tau, \theta > -\frac{1}{2}$ , and write  $v = \sigma + \tau - 2\theta$ . This section is devoted to describe the scalar products

$$\hat{c}_{k,\ell} = \hat{c}_{\sigma,\tau,\theta,k,\ell} = \langle \phi_{\sigma,k}, \phi_{\tau,\ell} \rangle_\theta,$$

which will be needed to prove Theorem 1.10.3. Note that  $\hat{c}_{k,\ell} = 0$  if  $k + \ell$  is odd, and

$$\hat{c}_{\sigma,\tau,\theta,k,\ell} = \hat{c}_{\tau,\sigma,\theta,\ell,k} \tag{4.3.1}$$

for all  $k$  and  $\ell$ . Of course,  $\hat{c}_{k,\ell} = \delta_{k,\ell}$  if  $\sigma = \tau = \theta$ .

According to Section 4.1, if  $k$  and  $\ell$  are odd, then  $\hat{c}_{\sigma,\tau,\theta,k,\ell}$  is also defined when  $\sigma, \tau, \theta > -\frac{3}{2}$ , and we have

$$\hat{c}_{\sigma,\tau,\theta,k,\ell} = \langle x\phi_{\sigma+1,k-1}, x\phi_{\tau+1,\ell-1} \rangle_\theta = \hat{c}_{\sigma+1,\tau+1,\theta+1,k-1,\ell-1}. \tag{4.3.2}$$

**4.3.1 Case where  $\sigma = \theta \neq \tau$  and  $\tau - \sigma \notin -\mathbb{N}$** 

In this case, we have  $v = \tau - \sigma$ . By (4.1.1) and (4.2.1),

$$\hat{c}_{0,0} = s^{\frac{v}{2}} \Gamma(\sigma + \frac{1}{2})^{\frac{1}{2}} \Gamma(\tau + \frac{1}{2})^{-\frac{1}{2}}. \quad (4.3.3)$$

**Lemma 4.3.1.** *If  $k > 0$  is even, then  $\hat{c}_{k,0} = 0$ .*

*Proof.* By (4.1.2), (4.1.3) and (4.1.7),

$$\hat{c}_{k,0} = \frac{1}{\sqrt{2ks}} \langle B'_\sigma \phi_{\sigma,k-1}, \phi_{\tau,0} \rangle_\sigma = \frac{1}{\sqrt{2ks}} \langle \phi_{\sigma,k-1}, B_\tau \phi_{\tau,0} \rangle_\sigma = 0. \quad \square$$

**Lemma 4.3.2.** *If  $\ell = 2n > 0$ , then*

$$\hat{c}_{0,\ell} = \frac{v}{\sqrt{n}} \sum_{j=0}^{n-1} (-1)^{n-j} \sqrt{\frac{(n-1)! \Gamma(j + \frac{1}{2} + \tau)}{j! \Gamma(n + \frac{1}{2} + \tau)}} \hat{c}_{0,2j}.$$

*Proof.* By (4.1.2), (4.1.3), (4.1.6) and (4.1.8),

$$\begin{aligned} \hat{c}_{0,\ell} &= \frac{1}{\sqrt{2\ell s}} \langle \phi_{\sigma,0}, B'_\tau \phi_{\tau,\ell-1} \rangle_\sigma \\ &= \frac{1}{\sqrt{2\ell s}} \langle \phi_{\sigma,0}, (B'_\sigma - 2vx^{-1}) \phi_{\tau,\ell-1} \rangle_\sigma \\ &= \frac{1}{\sqrt{2\ell s}} \langle B_\sigma \phi_{\sigma,0}, \phi_{\tau,\ell-1} \rangle_\sigma \\ &\quad - \frac{2v}{\sqrt{2\ell}} \sum_{j=0}^{n-1} (-1)^{n-1-j} \sqrt{\frac{(n-1)! \Gamma(j + \frac{1}{2} + \tau)}{j! \Gamma(n + \frac{1}{2} + \tau)}} \hat{c}_{0,2j} \\ &= \frac{v}{\sqrt{n}} \sum_{j=0}^{n-1} (-1)^{n-j} \sqrt{\frac{(n-1)! \Gamma(j + \frac{1}{2} + \tau)}{j! \Gamma(n + \frac{1}{2} + \tau)}} \hat{c}_{0,2j}. \quad \square \end{aligned}$$

**Lemma 4.3.3.** *If  $k = 2m > 0$  and  $\ell = 2n > 0$ , then  $\hat{c}_{k,\ell} = \sqrt{n/m} \hat{c}_{k-1,\ell-1}$ .*

*Proof.* By (4.1.2), (4.1.4) and (4.1.7),

$$\begin{aligned} \hat{c}_{k,\ell} &= \frac{1}{\sqrt{2ks}} \langle B'_\sigma \phi_{\sigma,k-1}, \phi_{\tau,\ell} \rangle_\sigma = \frac{1}{\sqrt{2ks}} \langle \phi_{\sigma,k-1}, B_\sigma \phi_{\tau,\ell} \rangle_\sigma \\ &= \frac{1}{\sqrt{2ks}} \langle \phi_{\sigma,k-1}, B_\tau \phi_{\tau,\ell} \rangle_\sigma = \sqrt{\frac{2\ell s}{2ks}} \hat{c}_{k-1,\ell-1} = \sqrt{\frac{n}{m}} \hat{c}_{k-1,\ell-1}. \quad \square \end{aligned}$$

**Lemma 4.3.4.** *If  $k = 2m + 1$  and  $\ell = 2n + 1$ , then*

$$\begin{aligned} \hat{c}_{k,\ell} &= \frac{n + \frac{1}{2} + \sigma}{\sqrt{(m + \frac{1}{2} + \sigma)(n + \frac{1}{2} + \tau)}} \hat{c}_{k-1,\ell-1} \\ &\quad - \frac{v}{\sqrt{m + \frac{1}{2} + \sigma}} \sum_{j=0}^{n-1} (-1)^{n-j} \sqrt{\frac{n!\Gamma(j + \frac{1}{2} + \tau)}{j!\Gamma(n + \frac{3}{2} + \tau)}} \hat{c}_{k-1,2j}. \end{aligned}$$

*Proof.* By (4.1.2), (4.1.4), (4.1.6) and (4.1.7),

$$\begin{aligned} \hat{c}_{k,\ell} &= \frac{1}{\sqrt{2(k+2\sigma)s}} \langle B'_\sigma \phi_{\sigma,k-1}, \phi_{\tau,\ell} \rangle_\sigma \\ &= \frac{1}{\sqrt{2(k+2\sigma)s}} \langle \phi_{\sigma,k-1}, (B_\tau - 2vx^{-1})\phi_{\tau,\ell} \rangle_\sigma \\ &= \sqrt{\frac{n + \frac{1}{2} + \tau}{m + \frac{1}{2} + \sigma}} \hat{c}_{k-1,\ell-1} \\ &\quad - \frac{v}{\sqrt{m + \frac{1}{2} + \sigma}} \sum_{j=0}^n (-1)^{n-j} \sqrt{\frac{n!\Gamma(j + \frac{1}{2} + \tau)}{j!\Gamma(n + \frac{3}{2} + \tau)}} \hat{c}_{k-1,2j} \\ &= \frac{n + \frac{1}{2} + \sigma}{\sqrt{(m + \frac{1}{2} + \sigma)(n + \frac{1}{2} + \tau)}} \hat{c}_{k-1,\ell-1} \\ &\quad - \frac{v}{\sqrt{m + \frac{1}{2} + \sigma}} \sum_{j=0}^{n-1} (-1)^{n-j} \sqrt{\frac{n!\Gamma(j + \frac{1}{2} + \tau)}{j!\Gamma(n + \frac{3}{2} + \tau)}} \hat{c}_{k-1,2j}. \quad \square \end{aligned}$$

**Corollary 4.3.5.** *If  $k > \ell$ , then  $\hat{c}_{k,\ell} = 0$ .*

*Proof.* This follows by induction on  $\ell$  using Lemmas 4.3.1, 4.3.3 and 4.3.4. □

*Remark 4.3.6.* By Corollary 4.3.5, in Lemma 4.3.4, it is enough to consider the sum with  $j$  running from  $m$  to  $n - 1$ .

**Proposition 4.3.7.** *If  $k = 2m \leq \ell = 2n$ , then*

$$\hat{c}_{k,\ell} = (-1)^{m+n} s^{\frac{v}{2}} \sqrt{\frac{n!\Gamma(m + \frac{1}{2} + \sigma)}{m!\Gamma(n + \frac{1}{2} + \tau)} \frac{\Gamma(n - m + v)}{(n - m)!\Gamma(v)}},$$

*and, if  $k = 2m + 1 \leq \ell = 2n + 1$ , then*

$$\hat{c}_{k,\ell} = (-1)^{m+n} s^{\frac{v}{2}} \sqrt{\frac{n!\Gamma(m + \frac{3}{2} + \sigma)}{m!\Gamma(n + \frac{3}{2} + \tau)} \frac{\Gamma(n - m + v)}{(n - m)!\Gamma(v)}}.$$

*Proof.* This is proved by induction on  $k$ . In turn, the case  $k = 0$ ,

$$\hat{c}_{0,\ell} = (-1)^n s^{\frac{v}{2}} \sqrt{\frac{\Gamma(\frac{1}{2} + \sigma)}{n! \Gamma(n + \frac{1}{2} + \tau)} \frac{\Gamma(n + v)}{\Gamma(v)}}, \quad (4.3.4)$$

is proved by induction on  $\ell$ . If  $k = \ell = 0$ , (4.3.4) coincides with (4.3.3). Given  $\ell = 2n > 0$ , assume that the result holds for  $k = 0$  and all  $\ell' = 2n' < \ell$ . Then, by Lemma 4.3.2,

$$\begin{aligned} \hat{c}_{0,\ell} &= \frac{v}{\sqrt{n}} \sum_{j=0}^{n-1} (-1)^{n-j} \sqrt{\frac{(n-1)! \Gamma(j + \frac{1}{2} + \tau)}{j! \Gamma(n + \frac{1}{2} + \tau)}} \\ &\quad \times (-1)^j s^{\frac{v}{2}} \sqrt{\frac{\Gamma(\frac{1}{2} + \sigma)}{j! \Gamma(j + \frac{1}{2} + \tau)} \frac{\Gamma(j + v)}{\Gamma(v)}} \\ &= (-1)^n s^{\frac{v}{2}} \sqrt{\frac{(n-1)! \Gamma(\frac{1}{2} + \sigma)}{n \Gamma(n + \frac{1}{2} + \tau)} \frac{v}{\Gamma(v)}} \sum_{j=0}^{n-1} \frac{\Gamma(j + v)}{j!}, \end{aligned}$$

obtaining (4.3.4) because

$$\frac{\Gamma(p + 1 + t)}{p!} = t \sum_{i=0}^p \frac{\Gamma(i + t)}{i!} \quad (4.3.5)$$

for all  $p \in \mathbb{N}$  and  $t \in \mathbb{R} \setminus (-\mathbb{N})$ , as can be easily checked by induction on  $p$ .

Given  $k > 0$ , assume that the result holds for all  $k' < k$ . If  $k$  is even, the statement follows directly from Lemma 4.3.3. If  $k$  is odd, by Lemma 4.3.4, Remark 4.3.6 and (4.3.5),

$$\begin{aligned} \hat{c}_{k,\ell} &= \frac{n + \frac{1}{2} + \sigma}{\sqrt{(m + \frac{1}{2} + \sigma)(n + \frac{1}{2} + \tau)}} \\ &\quad \times (-1)^{m+n} s^{\frac{v}{2}} \sqrt{\frac{n! \Gamma(m + \frac{1}{2} + \sigma)}{m! \Gamma(n + \frac{1}{2} + \tau)} \frac{\Gamma(n - m + v)}{(n - m)! \Gamma(v)}} \\ &\quad - \frac{v}{\sqrt{m + \frac{1}{2} + \sigma}} \sum_{j=m}^{n-1} (-1)^{n-j} \sqrt{\frac{n! \Gamma(j + \frac{1}{2} + \tau)}{j! \Gamma(n + \frac{3}{2} + \tau)}} \\ &\quad \times (-1)^{m+j} s^{\frac{v}{2}} \sqrt{\frac{j! \Gamma(m + \frac{1}{2} + \sigma)}{m! \Gamma(j + \frac{1}{2} + \tau)} \frac{\Gamma(j - m + v)}{(j - m)! \Gamma(v)}} \end{aligned}$$

$$\begin{aligned}
 &= (-1)^{m+n} s^{\frac{v}{2}} \sqrt{\frac{n! \Gamma(m + \frac{1}{2} + \sigma)}{(m + \frac{1}{2} + \sigma) m! \Gamma(n + \frac{3}{2} + \tau)} \frac{1}{\Gamma(v)}} \\
 &\quad \times \left( \frac{\Gamma(n - m + v) (n + \frac{1}{2} + \sigma)}{(n - m)!} - v \sum_{i=0}^{n-m-1} \frac{\Gamma(i + v)}{i!} \right) \\
 &= (-1)^{m+n} s^{\frac{v}{2}} \sqrt{\frac{n! \Gamma(m + \frac{3}{2} + \sigma) \Gamma(n - m + v)}{m! \Gamma(n + \frac{3}{2} + \tau) (n - m)! \Gamma(v)}}. \quad \square
 \end{aligned}$$

*Remark 4.3.8.* By (4.3.2), if  $k$  and  $\ell$  are odd, then Corollary 4.3.5 and Proposition 4.3.7 also hold when  $\sigma, \tau > -\frac{3}{2}$ .

### 4.3.2 Case where $\sigma \neq \theta \neq \tau$ and $\sigma - \theta, \tau - \theta \notin -\mathbb{N}$

By (4.1.1) and (4.2.1),

$$\hat{c}_{0,0} = s^{\frac{v}{2}} \Gamma(\sigma + \frac{1}{2})^{-\frac{1}{2}} \Gamma(\tau + \frac{1}{2})^{-\frac{1}{2}} \Gamma(\theta + \frac{1}{2}). \quad (4.3.6)$$

**Lemma 4.3.9.** *If  $k = 2m > 0$ , then*

$$\hat{c}_{k,0} = \frac{\sigma - \theta}{\sqrt{m}} \sum_{i=0}^{m-1} (-1)^{m-i} \sqrt{\frac{(m-1)! \Gamma(i + \frac{1}{2} + \sigma)}{i! \Gamma(m + \frac{1}{2} + \sigma)}} \hat{c}_{2i,0}.$$

*Proof.* By (4.1.2) and (4.1.8),

$$\begin{aligned}
 \hat{c}_{k,0} &= \frac{1}{\sqrt{2ks}} \langle B'_\sigma \phi_{\sigma,k-1}, \phi_{\tau,0} \rangle_\theta \\
 &= \frac{1}{2\sqrt{ms}} \langle B'_\theta \phi_{\sigma,k-1}, \phi_{\tau,0} \rangle_\theta + \frac{\theta - \sigma}{\sqrt{ms}} \langle x^{-1} \phi_{\sigma,k-1}, \phi_{\tau,0} \rangle_\theta.
 \end{aligned}$$

Here, by (4.1.3), (4.1.6) and (4.1.7),

$$\begin{aligned}
 \langle B'_\theta \phi_{\sigma,k-1}, \phi_{\tau,0} \rangle_\theta &= \langle \phi_{\sigma,k-1}, B_\theta \phi_{\tau,0} \rangle_\theta = \langle \phi_{\sigma,k-1}, B_\tau \phi_{\tau,0} \rangle_\theta = 0, \\
 \langle x^{-1} \phi_{\sigma,k-1}, \phi_{\tau,0} \rangle_\theta &= - \sum_{i=0}^{m-1} (-1)^{m-i} \sqrt{\frac{(m-1)! \Gamma(i + \frac{1}{2} + \sigma) s}{i! \Gamma(m + \frac{1}{2} + \sigma)}} \hat{c}_{2i,0}. \quad \square
 \end{aligned}$$

**Lemma 4.3.10.** *If  $k = 2m > 0$  and  $\ell = 2n > 0$ , then*

$$\hat{c}_{k,\ell} = \sqrt{\frac{n}{m}} \hat{c}_{k-1,\ell-1} + \frac{\sigma - \theta}{m} \sum_{i=0}^{m-1} (-1)^{m-i} \sqrt{\frac{m! \Gamma(i + \frac{1}{2} + \sigma)}{i! \Gamma(m + \frac{1}{2} + \sigma)}} \hat{c}_{2i,\ell}.$$

*Proof.* Like in the proof of Lemma 4.3.9,

$$\hat{c}_{k,\ell} = \frac{1}{2\sqrt{ms}} \langle B'_\theta \phi_{\sigma,k-1}, \phi_{\tau,\ell} \rangle_\theta + \frac{\theta - \sigma}{\sqrt{ms}} \langle x^{-1} \phi_{\sigma,k-1}, \phi_{\tau,\ell} \rangle_\theta.$$

Now, by (4.1.4), (4.1.6) and (4.1.7),

$$\begin{aligned} \langle B'_\theta \phi_{\sigma,k-1}, \phi_{\tau,\ell} \rangle_\theta &= \langle \phi_{\sigma,k-1}, B_\theta \phi_{\tau,\ell} \rangle_\theta = \langle \phi_{\sigma,k-1}, B_\tau \phi_{\tau,\ell} \rangle_\theta = 2\sqrt{ns} \hat{c}_{k-1,\ell-1}, \\ \langle x^{-1} \phi_{\sigma,k-1}, \phi_{\tau,\ell} \rangle_\theta &= - \sum_{i=0}^{m-1} (-1)^{m-i} \sqrt{\frac{(m-1)! \Gamma(i + \frac{1}{2} + \sigma)s}{i! \Gamma(m + \frac{1}{2} + \sigma)}} \hat{c}_{2i,\ell}. \quad \square \end{aligned}$$

**Lemma 4.3.11.** *If  $k = 2m + 1$  and  $\ell = 2n + 1$ , then*

$$\begin{aligned} \hat{c}_{k,\ell} &= \frac{m + \frac{1}{2} + \theta}{\sqrt{(m + \frac{1}{2} + \sigma)(n + \frac{1}{2} + \tau)}} \hat{c}_{k-1,\ell-1} \\ &\quad - \frac{\sigma - \theta}{\sqrt{n + \frac{1}{2} + \tau}} \sum_{i=0}^{m-1} (-1)^{m-i} \sqrt{\frac{m! \Gamma(i + \frac{1}{2} + \sigma)}{i! \Gamma(m + \frac{3}{2} + \sigma)}} \hat{c}_{2i,\ell-1}. \end{aligned}$$

*Proof.* By (4.1.2),

$$\hat{c}_{k,\ell} = \frac{1}{2\sqrt{(n + \frac{1}{2} + \tau)s}} \langle \phi_{\sigma,k}, B'_\tau \phi_{\tau,\ell-1} \rangle_\theta,$$

where, by (4.1.8),

$$\begin{aligned} \langle \phi_{\sigma,k}, B'_\tau \phi_{\tau,\ell-1} \rangle_\theta &= \langle \phi_{\sigma,k}, B'_\theta \phi_{\tau,\ell-1} \rangle_\theta = \langle B_\theta \phi_{\sigma,k}, \phi_{\tau,\ell-1} \rangle_\theta \\ &= \langle B_\sigma \phi_{\sigma,k}, \phi_{\tau,\ell-1} \rangle_\theta + 2(\theta - \sigma) \langle x^{-1} \phi_{\sigma,k}, \phi_{\tau,\ell-1} \rangle_\theta. \end{aligned}$$

Hence, by (4.1.4) and (4.1.6),

$$\begin{aligned} \hat{c}_{k,\ell} &= \sqrt{\frac{m + \frac{1}{2} + \sigma}{n + \frac{1}{2} + \tau}} \hat{c}_{k-1,\ell-1} \\ &\quad - \frac{\sigma - \theta}{\sqrt{n + \frac{1}{2} + \tau}} \sum_{i=0}^m (-1)^{m-i} \sqrt{\frac{m! \Gamma(i + \frac{1}{2} + \sigma)}{i! \Gamma(m + \frac{3}{2} + \sigma)}} \hat{c}_{2i,\ell-1} \\ &= \frac{m + \frac{1}{2} + \theta}{\sqrt{(n + \frac{1}{2} + \tau)(m + \frac{1}{2} + \sigma)}} \hat{c}_{k-1,\ell-1} \\ &\quad - \frac{\sigma - \theta}{\sqrt{n + \frac{1}{2} + \tau}} \sum_{i=0}^{m-1} (-1)^{m-i} \sqrt{\frac{m! \Gamma(i + \frac{1}{2} + \sigma)}{i! \Gamma(m + \frac{3}{2} + \sigma)}} \hat{c}_{2i,\ell-1}. \quad \square \end{aligned}$$

**Proposition 4.3.12.** *If  $k = 2m$  and  $\ell = 2n$ , then*

$$\begin{aligned} \hat{c}_{k,\ell} &= (-1)^{m+n} s^{\frac{\nu}{2}} \sqrt{\frac{m!n!}{\Gamma(m + \frac{1}{2} + \sigma)\Gamma(n + \frac{1}{2} + \tau)}} \\ &\times \sum_{p=0}^{\min\{m,n\}} \frac{\Gamma(p + \frac{1}{2} + \theta)\Gamma(m - p + \sigma - \theta)\Gamma(n - p + \tau - \theta)}{p!(m - p)!(n - p)!\Gamma(\sigma - \theta)\Gamma(\tau - \theta)}, \end{aligned}$$

and, if  $k = 2m + 1$  and  $\ell = 2n + 1$ , then

$$\begin{aligned} \hat{c}_{k,\ell} &= (-1)^{m+n} s^{\frac{\nu}{2}} \sqrt{\frac{m!n!}{\Gamma(m + \frac{3}{2} + \sigma)\Gamma(n + \frac{3}{2} + \tau)}} \\ &\times \sum_{p=0}^{\min\{m,n\}} \frac{\Gamma(p + \frac{3}{2} + \theta)\Gamma(m - p + \sigma - \theta)\Gamma(n - p + \tau - \theta)}{p!(m - p)!(n - p)!\Gamma(\sigma - \theta)\Gamma(\tau - \theta)}. \end{aligned}$$

*Proof.* The result is proved by induction on  $k$  and  $\ell$ . First, consider the case  $\ell = 0$ . When  $k = \ell = 0$ , the result is given by (4.3.6). Now, take any  $k = 2m > 0$ , and assume that the result holds for all  $\hat{c}_{k',0}$  with  $k' = 2m' < k$ . Then, by Lemma 4.3.9 and (4.3.5),

$$\begin{aligned} \hat{c}_{k,0} &= \frac{\sigma - \theta}{\sqrt{m}} \sum_{i=0}^{m-1} (-1)^{m-i} \sqrt{\frac{(m-1)!\Gamma(i + \frac{1}{2} + \sigma)}{i!\Gamma(m + \frac{1}{2} + \sigma)}} \\ &\times (-1)^i s^{\frac{\nu}{2}} \sqrt{\frac{1}{i!\Gamma(i + \frac{1}{2} + \sigma)\Gamma(\frac{1}{2} + \tau)}} \Gamma(\frac{1}{2} + \theta) \frac{\Gamma(i + \sigma - \theta)}{\Gamma(\sigma - \theta)} \\ &= (-1)^m s^{\frac{\nu}{2}} \sqrt{\frac{m!}{\Gamma(m + \frac{1}{2} + \sigma)\Gamma(\frac{1}{2} + \tau)}} \Gamma(\frac{1}{2} + \theta) \frac{\sigma - \theta}{m} \sum_{i=0}^{m-1} \frac{\Gamma(i + \sigma - \theta)}{i!\Gamma(\sigma - \theta)} \\ &= (-1)^m s^{\frac{\nu}{2}} \sqrt{\frac{1}{m!\Gamma(m + \frac{1}{2} + \sigma)\Gamma(\frac{1}{2} + \tau)}} \Gamma(\frac{1}{2} + \theta) \frac{\Gamma(m + \sigma - \theta)}{\Gamma(\sigma - \theta)}. \end{aligned}$$

From the case  $\ell = 0$ , the result also follows for the case  $k = 0$  by (4.3.1).

Now, take  $k = 2m > 0$  and  $\ell = 2n > 0$ , and assume that the result holds for all

$\hat{c}_{k,\ell}$  with  $k' < k$  and  $\ell' \leq \ell$ . By Lemma 4.3.10,

$$\begin{aligned}
 \hat{c}_{k,\ell} &= \sqrt{\frac{n}{m}} (-1)^{m+n-2} s^{\frac{v}{2}} \sqrt{\frac{(m-1)!(n-1)!}{\Gamma(m+\frac{1}{2}+\sigma)\Gamma(n+\frac{1}{2}+\tau)}} \\
 &\times \sum_{q=0}^{\min\{m,n\}-1} \frac{\Gamma(q+\frac{3}{2}+\theta)\Gamma(m-1-q+\sigma-\theta)\Gamma(n-1-q+\tau-\theta)}{q!(m-1-q)!(n-1-q)!\Gamma(\sigma-\theta)\Gamma(\tau-\theta)} \\
 &+ \frac{\sigma-\theta}{m} \sum_{i=0}^{m-1} (-1)^{m-i} \sqrt{\frac{m!\Gamma(i+\frac{1}{2}+\sigma)}{i!\Gamma(m+\frac{1}{2}+\sigma)}} \\
 &\times (-1)^{i+n} s^{\frac{v}{2}} \sqrt{\frac{i!n!}{\Gamma(i+\frac{1}{2}+\sigma)\Gamma(n+\frac{1}{2}+\tau)}} \\
 &\times \sum_{p=0}^{\min\{i,n\}} \frac{\Gamma(p+\frac{1}{2}+\theta)\Gamma(i-p+\sigma-\theta)\Gamma(n-p+\tau-\theta)}{p!(i-p)!(n-p)!\Gamma(\sigma-\theta)\Gamma(\tau-\theta)} \\
 &= (-1)^{m+n} s^{\frac{v}{2}} \frac{1}{m} \sqrt{\frac{m!n!}{\Gamma(m+\frac{1}{2}+\sigma)\Gamma(n+\frac{1}{2}+\tau)}} \\
 &\times \left( \sum_{q=0}^{\min\{m,n\}-1} \frac{\Gamma(q+\frac{3}{2}+\theta)\Gamma(m-1-q+\sigma-\theta)\Gamma(n-1-q+\tau-\theta)}{q!(m-1-q)!(n-1-q)!\Gamma(\sigma-\theta)\Gamma(\tau-\theta)} \right. \\
 &\left. + (\sigma-\theta) \sum_{i=0}^{m-1} \sum_{p=0}^{\min\{i,n\}} \frac{\Gamma(p+\frac{1}{2}+\theta)\Gamma(i-p+\sigma-\theta)\Gamma(n-p+\tau-\theta)}{p!(i-p)!(n-p)!\Gamma(\sigma-\theta)\Gamma(\tau-\theta)} \right).
 \end{aligned}$$

Then the desired expression for  $\hat{c}_{k,\ell}$  follows because

$$\begin{aligned}
 &\sum_{q=0}^{\min\{m,n\}-1} \frac{\Gamma(q+\frac{3}{2}+\theta)\Gamma(m-1-q+\sigma-\theta)\Gamma(n-1-q+\tau-\theta)}{q!(m-1-q)!(n-1-q)!\Gamma(\sigma-\theta)\Gamma(\tau-\theta)} \\
 &= \sum_{p=0}^{\min\{m,n\}} \frac{p\Gamma(p+\frac{1}{2}+\theta)\Gamma(m-p+\sigma-\theta)\Gamma(n-p+\tau-\theta)}{p!(m-p)!(n-p)!\Gamma(\sigma-\theta)\Gamma(\tau-\theta)},
 \end{aligned}$$

and, by (4.3.5),

$$(\sigma-\theta) \sum_{i=0}^{m-1} \sum_{p=0}^{\min\{i,n\}} \frac{\Gamma(p+\frac{1}{2}+\theta)\Gamma(i-p+\sigma-\theta)\Gamma(n-p+\tau-\theta)}{p!(i-p)!(n-p)!\Gamma(\sigma-\theta)\Gamma(\tau-\theta)}$$

$$\begin{aligned}
 &= (\sigma - \theta) \sum_{p=0}^{\min\{m-1, n\}} \sum_{j=0}^{m-1-p} \frac{\Gamma(p + \frac{1}{2} + \theta) \Gamma(j + \sigma - \theta) \Gamma(n - p + \tau - \theta)}{p! j! (n - p)! \Gamma(\sigma - \theta) \Gamma(\tau - \theta)} \\
 &= \sum_{p=0}^{\min\{m, n\}} \frac{\Gamma(p + \frac{1}{2} + \theta) (m - p) \Gamma(m - p + \sigma - \theta) \Gamma(n - p + \tau - \theta)}{p! (m - p)! (n - p)! \Gamma(\sigma - \theta) \Gamma(\tau - \theta)}. \quad (4.3.7)
 \end{aligned}$$

Finally, take  $k = 2m + 1$  and  $\ell = 2n + 1$ , and assume that the result holds for all  $\hat{c}_{k', \ell'}$  with  $k' < k$  and  $\ell' < \ell$ . By Lemma 4.3.11,

$$\begin{aligned}
 \hat{c}_{k, \ell} &= \frac{(m + \frac{1}{2} + \theta) (-1)^{m+n} s^{\frac{v}{2}}}{\sqrt{(m + \frac{1}{2} + \sigma)(n + \frac{1}{2} + \tau)}} \sqrt{\frac{m! n!}{\Gamma(m + \frac{1}{2} + \sigma) \Gamma(n + \frac{1}{2} + \tau)}} \\
 &\times \sum_{p=0}^{\min\{m, n\}} \frac{\Gamma(p + \frac{1}{2} + \theta) \Gamma(m - p + \sigma - \theta) \Gamma(n - p + \tau - \theta)}{p! (m - p)! (n - p)! \Gamma(\sigma - \theta) \Gamma(\tau - \theta)} \\
 &- \frac{\sigma - \theta}{\sqrt{n + \frac{1}{2} + \tau}} \sum_{i=0}^{m-1} (-1)^{m-i} \sqrt{\frac{m! \Gamma(i + \frac{1}{2} + \sigma)}{i! \Gamma(m + \frac{3}{2} + \sigma)}} \\
 &\times (-1)^{i+n} s^{\frac{v}{2}} \sqrt{\frac{i! n!}{\Gamma(i + \frac{1}{2} + \sigma) \Gamma(n + \frac{1}{2} + \tau)}} \\
 &\times \sum_{p=0}^{\min\{i, n\}} \frac{\Gamma(p + \frac{1}{2} + \theta) \Gamma(i - p + \sigma - \theta) \Gamma(n - p + \tau - \theta)}{p! (i - p)! (n - p)! \Gamma(\sigma - \theta) \Gamma(\tau - \theta)} \\
 &= (-1)^{m+n} s^{\frac{v}{2}} \sqrt{\frac{m! n!}{\Gamma(m + \frac{3}{2} + \sigma) \Gamma(n + \frac{3}{2} + \tau)}} \\
 &\times \left( \sum_{p=0}^{\min\{m, n\}} \frac{(m + \frac{1}{2} + \theta) \Gamma(p + \frac{1}{2} + \theta) \Gamma(m - p + \sigma - \theta) \Gamma(n - p + \tau - \theta)}{p! (m - p)! (n - p)! \Gamma(\sigma - \theta) \Gamma(\tau - \theta)} \right. \\
 &\left. - (\sigma - \theta) \sum_{i=0}^{m-1} \sum_{p=0}^{\min\{i, n\}} \frac{\Gamma(p + \frac{1}{2} + \theta) \Gamma(i - p + \sigma - \theta) \Gamma(n - p + \tau - \theta)}{p! (i - p)! (n - p)! \Gamma(\sigma - \theta) \Gamma(\tau - \theta)} \right).
 \end{aligned}$$

Then we get the stated expression for  $\hat{c}_{k, \ell}$  using (4.3.7) again. □

*Remark 4.3.13.* By (4.3.2), if  $k$  and  $\ell$  are odd, then Proposition 4.3.12 also holds when  $\sigma, \tau > -\frac{3}{2}$ .

## 4.4 The sesquilinear form $\mathfrak{t}'$

Consider the notation of Section 4.3. Since  $x^{-1}\mathcal{S}_{\text{odd}} = \mathcal{S}_{\text{ev}}$ , a sesquilinear form  $\mathfrak{t}'$  in  $L^2_{\sigma,\tau}$ , with  $D(\mathfrak{t}') = \mathcal{S}$ , is defined by

$$\mathfrak{t}'(\phi, \psi) = \langle \phi_{\text{ev}}, x^{-1}\psi_{\text{odd}} \rangle_{\theta} = \langle x\phi_{\text{ev}}, \psi_{\text{odd}} \rangle_{\theta-1}.$$

Note that  $\mathfrak{t}'$  is neither symmetric nor bounded from the left. The goal of this section is to study  $\mathfrak{t}'$ , and use it to prove Theorem 1.10.3.

Let  $c'_{k,\ell} = \mathfrak{t}'(\phi_{\sigma,k}, \phi_{\tau,\ell})$ . Clearly,  $c'_{k,\ell} = 0$  if  $k$  is odd or  $\ell$  is even.

### 4.4.1 Case where $\sigma = \theta = \tau$

In this case, we have  $v = 0$ .

**Proposition 4.4.1.** *For  $k = 2m$  and  $\ell = 2n + 1$ , if  $k > \ell$  ( $m > n$ ), then  $c'_{k,\ell} = 0$ , and, if  $k < \ell$  ( $m \leq n$ ), then*

$$c'_{k,\ell} = (-1)^{n-m} s^{\frac{1}{2}} \sqrt{\frac{n!\Gamma(m + \frac{1}{2} + \sigma)}{m!\Gamma(n + \frac{3}{2} + \sigma)}}.$$

*Proof.* This follows from (4.1.6) since  $\hat{c}_{k,\ell} = \delta_{k,\ell}$  in this case.  $\square$

**Proposition 4.4.2.** *There is some  $\omega = \omega(\sigma) > 0$  so that, for  $k = 2m$  and  $\ell = 2n + 1$ ,*

$$|c'_{k,\ell}| \lesssim s^{\frac{1}{2}} (m+1)^{-\omega} (n+1)^{-\omega}.$$

*Proof.* We can assume that  $m \leq n$  according to Proposition 4.4.1. Moreover

$$|c'_{k,\ell}| \lesssim s^{\frac{1}{2}} (m+1)^{\frac{\sigma}{2} - \frac{1}{4}} (n+1)^{-\frac{\sigma}{2} - \frac{1}{4}}$$

for all  $m \leq n$  by Proposition 4.4.1 and Lemma 4.2.12. Therefore the result follows using Lemma 4.2.14, reversing the roles of  $m$  and  $n$ , because  $-\frac{\sigma}{2} - \frac{1}{4} < -\frac{u}{2} < 0$ .  $\square$

### 4.4.2 Case where $\sigma = \theta \neq \tau$ and $\tau - \sigma \notin -\mathbb{N}$

Recall that  $v = \tau - \sigma$  in this case. Moreover  $c'_{k,\ell} = 0$  if  $k > \ell$  by (4.1.6) and Corollary 4.3.5.

**Proposition 4.4.3.** *For  $k = 2m < \ell = 2n + 1$  ( $m \leq n$ ),*

$$c'_{k,\ell} = (-1)^{m+n} s^{\frac{1+v}{2}} \sqrt{\frac{n!\Gamma(m + \frac{1}{2} + \sigma)}{m!\Gamma(n + \frac{3}{2} + \tau)} \frac{\Gamma(n - m + 1 + v)}{(n - m)!\Gamma(1 + v)}}.$$

*Proof.* By (4.1.6), Corollary 4.3.5, Proposition 4.3.7 and (4.3.5),

$$\begin{aligned}
 c'_{k,\ell} &= s^{\frac{1}{2}} \sum_{j=m}^n (-1)^{n-j} \sqrt{\frac{n!\Gamma(j + \frac{1}{2} + \tau)}{j!\Gamma(n + \frac{3}{2} + \tau)}} \\
 &\quad \times (-1)^{m+j} s^{\frac{v}{2}} \sqrt{\frac{j!\Gamma(m + \frac{1}{2} + \sigma)}{m!\Gamma(j + \frac{1}{2} + \tau)} \frac{\Gamma(j - m + v)}{(j - m)!\Gamma(v)}} \\
 &= (-1)^{m+n} s^{\frac{1+v}{2}} \sqrt{\frac{n!\Gamma(m + \frac{1}{2} + \sigma)}{m!\Gamma(n + \frac{3}{2} + \tau)} \frac{1}{\Gamma(v)}} \sum_{i=0}^{n-m} \frac{\Gamma(i + v)}{i!} \\
 &= (-1)^{m+n} s^{\frac{1+v}{2}} \sqrt{\frac{n!\Gamma(m + \frac{1}{2} + \sigma)}{m!\Gamma(n + \frac{3}{2} + \tau)} \frac{\Gamma(n - m + 1 + v)}{(n - m)!\Gamma(1 + v)}}. \quad \square
 \end{aligned}$$

**Proposition 4.4.4.** *If  $(\sigma, \tau)$  satisfies (1.10.5), then there is some  $\omega = \omega(\sigma, \tau) > 0$  so that, for  $k = 2m < \ell = 2n + 1$ ,*

$$|c'_{k,\ell}| \asymp s^{\frac{1+v}{2}} (m+1)^{-\omega} (n+1)^{-\omega}.$$

*Proof.* By Proposition 4.4.3 and Lemma 4.2.12,

$$|c'_{k,\ell}| \asymp s^{\frac{1+v}{2}} (m+1)^{\frac{\sigma}{2} - \frac{1}{4}} (n+1)^{-\frac{\tau}{2} - \frac{1}{4}} (n-m+1)^v.$$

Then the result follows by Lemma 4.2.14, interchanging the roles of  $m$  and  $n$ , using the condition of Theorem 1.10.3-(a).  $\square$

### 4.4.3 Case where $\sigma \neq \theta = \tau$ and $\sigma - \theta \notin -\mathbb{N}$

Recall that  $v = \sigma - \tau$  in this case.

**Proposition 4.4.5.** *For  $k = 2m$  and  $\ell = 2n + 1$ ,*

$$\begin{aligned}
 c'_{k,\ell} &= (-1)^{m+n} s^{\frac{1+v}{2}} \sqrt{\frac{m!n!}{\Gamma(m + \frac{1}{2} + \sigma)\Gamma(n + \frac{3}{2} + \tau)}} \\
 &\quad \times \sum_{j=0}^{\min\{m,n\}} \frac{\Gamma(j + \frac{1}{2} + \tau)\Gamma(m - j + v)}{j!(m - j)!\Gamma(v)}.
 \end{aligned}$$

*Proof.* By (4.1.6), Corollary 4.3.5, Proposition 4.3.7 and (4.3.1),

$$\begin{aligned}
 c'_{k,\ell} &= s^{\frac{1}{2}} \sum_{j=0}^{\min\{m,n\}} (-1)^{n-j} \sqrt{\frac{n!\Gamma(j + \frac{1}{2} + \tau)}{j!\Gamma(n + \frac{3}{2} + \tau)}} \\
 &\quad \times (-1)^{j+m} s^{\frac{v}{2}} \sqrt{\frac{m!\Gamma(j + \frac{1}{2} + \tau) \Gamma(m-j+v)}{j!\Gamma(m + \frac{1}{2} + \sigma) (m-j)!\Gamma(v)}} \\
 &= (-1)^{m+n} s^{\frac{1+v}{2}} \sqrt{\frac{m!n!}{\Gamma(m + \frac{1}{2} + \sigma)\Gamma(n + \frac{3}{2} + \tau)}} \\
 &\quad \times \sum_{j=0}^{\min\{m,n\}} \frac{\Gamma(j + \frac{1}{2} + \tau)\Gamma(m-j+v)}{j!(m-j)!\Gamma(v)}. \quad \square
 \end{aligned}$$

**Proposition 4.4.6.** *If  $(\sigma, \tau)$  satisfies (1.10.6), then there is some  $\omega = \omega(\sigma, \tau) > 0$  so that, for  $k = 2m$  and  $\ell = 2n + 1$ ,*

$$|c'_{k,\ell}| \lesssim s^{\frac{1+v}{2}} (m+1)^{-\omega} (n+1)^{-\omega}.$$

*Proof.* By Proposition 4.4.5 and Lemma 4.2.12,

$$|c'_{k,\ell}| \lesssim s^{\frac{1+v}{2}} (m+1)^{\frac{1}{4}-\frac{\sigma}{2}} (n+1)^{-\frac{1}{4}-\frac{\tau}{2}} \sum_{j=0}^{\min\{m,n\}} (m-j+1)^{v-1} (j+1)^{\tau-\frac{1}{2}}.$$

Then the result follows by Corollary 4.6.4, proved in Section 4.6, since  $(\sigma, \tau)$  satisfies (1.10.6).  $\square$

#### 4.4.4 Case where $\sigma \neq \theta = \tau + 1$ and $\sigma - \tau - 1 \notin -\mathbb{N}$

Note that  $v = \sigma - \tau - 2$  in this case. Moreover

$$c'_{k,\ell} = \langle \phi_{\sigma,k}, x^{-1} \phi_{\tau,\ell} \rangle_{\tau+1} = \langle x \phi_{\sigma,k}, \phi_{\tau,\ell} \rangle_{\tau} = \langle \phi_{\tau,\ell}, x \phi_{\sigma,k} \rangle_{\tau} \quad (4.4.1)$$

for  $k = 2m$  and  $\ell = 2n + 1$  (Remark 1.10.4-(ii)).

**Proposition 4.4.7.** *Let  $k = 2m$  and  $\ell = 2n + 1$ . If  $k+1 < \ell$  ( $m < n$ ), then  $c'_{k,\ell} = 0$ . If  $k+1 \geq \ell$  ( $m \geq n$ ), then*

$$c'_{k,\ell} = (-1)^{m+n} s^{\frac{v+1}{2}} \sqrt{\frac{m!\Gamma(n + \frac{3}{2} + \tau) \Gamma(m-n+v+1)}{n!\Gamma(m + \frac{1}{2} + \sigma) (m-n)!\Gamma(v+1)}}.$$

*Proof.* By (4.1.5) and (4.4.1),

$$c'_{k,\ell} = \sqrt{\frac{m + \frac{1}{2} + \sigma}{s}} \hat{c}_{\tau,\sigma,\tau,\ell,k+1} + \sqrt{\frac{m}{s}} \hat{c}_{\tau,\sigma,\tau,\ell,k-1}. \quad (4.4.2)$$

So  $c'_{k,\ell} = 0$  if  $k + 1 < \ell$  by Corollary 4.3.5. When  $k + 1 = \ell$  ( $m = n$ ), by (4.4.2) and Proposition 4.3.7,

$$c'_{k,\ell} = \sqrt{\frac{m + \frac{1}{2} + \sigma}{s}} s^{\frac{v+2}{2}} \sqrt{\frac{\Gamma(n + \frac{3}{2} + \tau)}{\Gamma(m + \frac{3}{2} + \sigma)}} = s^{\frac{v+1}{2}} \sqrt{\frac{\Gamma(n + \frac{3}{2} + \tau)}{\Gamma(m + \frac{1}{2} + \sigma)}}.$$

When  $k - 1 \geq \ell$  ( $m > n$ ), by (4.4.2) and Proposition 4.3.7,

$$\begin{aligned} c'_{k,\ell} &= \sqrt{\frac{m + \frac{1}{2} + \sigma}{s}} (-1)^{m+n} s^{\frac{v+2}{2}} \sqrt{\frac{m! \Gamma(n + \frac{3}{2} + \tau)}{n! \Gamma(m + \frac{3}{2} + \sigma)}} \frac{\Gamma(m - n + v + 2)}{(m - n)! \Gamma(v + 2)} \\ &\quad + \sqrt{\frac{m}{s}} (-1)^{m+n-1} s^{\frac{v+2}{2}} \sqrt{\frac{(m-1)! \Gamma(n + \frac{3}{2} + \tau)}{n! \Gamma(m + \frac{1}{2} + \sigma)}} \frac{\Gamma(m - n + v + 1)}{(m - 1 - n)! \Gamma(v + 2)} \\ &= (-1)^{m+n} s^{\frac{v+1}{2}} \sqrt{\frac{m! \Gamma(n + \frac{3}{2} + \tau)}{n! \Gamma(m + \frac{1}{2} + \sigma)}} \frac{\Gamma(m - n + v + 1)}{(m - 1 - n)! \Gamma(v + 2)} \\ &\quad \times \left( \frac{m - n + v + 1}{m - n} - 1 \right) \\ &= (-1)^{m+n} s^{\frac{v+1}{2}} \sqrt{\frac{m! \Gamma(n + \frac{3}{2} + \tau)}{n! \Gamma(m + \frac{1}{2} + \sigma)}} \frac{\Gamma(m - n + v + 1)}{(m - n)! \Gamma(v + 1)}. \quad \square \end{aligned}$$

**Proposition 4.4.8.** *If  $(\sigma, \tau)$  satisfies (1.10.7), then there is some  $\omega = \omega(\sigma, \tau) > 0$  so that, for  $k = 2m$  and  $\ell = 2n + 1$ ,*

$$|c'_{k,\ell}| \preceq s^{\frac{v+1}{2}} (m + 1)^{-\omega} (n + 1)^{-\omega}.$$

*Proof.* By Proposition 4.4.7, we can assume that  $k + 1 \geq \ell$  ( $m \geq n$ ), and, in this case, using also Lemma 4.2.12, we get

$$|c'_{k,\ell}| \preceq s^{\frac{v+1}{2}} (m + 1)^{\frac{1}{4} - \frac{\sigma}{2}} (n + 1)^{\frac{1}{4} + \frac{\tau}{2}} (m - n + 1)^v.$$

Then the result follows using Lemma 4.2.14. □

#### 4.4.5 Case where $\sigma \neq \theta \neq \tau$ and $\sigma - \theta, \tau - \theta \notin -\mathbb{N}$

**Proposition 4.4.9.** For  $k = 2m$  and  $\ell = 2n + 1$ ,

$$\begin{aligned} c'_{k,\ell} &= (-1)^{m+n} s^{\frac{1+v}{2}} \sqrt{\frac{m!n!}{\Gamma(m + \frac{1}{2} + \sigma)\Gamma(n + \frac{3}{2} + \tau)}} \\ &\times \sum_{p=0}^{\min\{m,n\}} \frac{\Gamma(p + \frac{1}{2} + \theta)\Gamma(m - p + \sigma - \theta)\Gamma(n - p + 1 + \tau - \theta)}{p!(m-p)!(n-p)!\Gamma(\sigma - \theta)\Gamma(1 + \tau - \theta)}. \end{aligned}$$

*Proof.* By (4.1.6) and Proposition 4.3.12,

$$\begin{aligned} c'_{k,\ell} &= s^{\frac{1}{2}} \sum_{j=0}^n (-1)^{n-j} \sqrt{\frac{n!\Gamma(j + \frac{1}{2} + \tau)}{j!\Gamma(n + \frac{3}{2} + \tau)}} \\ &\times (-1)^{m+j} s^{\frac{v}{2}} \sqrt{\frac{m!j!}{\Gamma(m + \frac{1}{2} + \sigma)\Gamma(j + \frac{1}{2} + \tau)}} \\ &\times \sum_{p=0}^{\min\{m,j\}} \frac{\Gamma(p + \frac{1}{2} + \theta)\Gamma(m - p + \sigma - \theta)\Gamma(j - p + \tau - \theta)}{p!(m-p)!(j-p)!\Gamma(\sigma - \theta)\Gamma(\tau - \theta)} \\ &= (-1)^{m+n} s^{\frac{1+v}{2}} \sqrt{\frac{m!n!}{\Gamma(m + \frac{1}{2} + \sigma)\Gamma(n + \frac{3}{2} + \tau)}} \\ &\times \sum_{j=0}^n \sum_{p=0}^{\min\{m,j\}} \frac{\Gamma(p + \frac{1}{2} + \theta)\Gamma(m - p + \sigma - \theta)\Gamma(j - p + \tau - \theta)}{p!(m-p)!(j-p)!\Gamma(\sigma - \theta)\Gamma(\tau - \theta)}. \end{aligned}$$

But, by (4.3.5),

$$\begin{aligned} &\sum_{j=0}^n \sum_{p=0}^{\min\{m,j\}} \frac{\Gamma(m - p + \sigma - \theta)\Gamma(j - p + \tau - \theta)}{(m-p)!(j-p)!\Gamma(\sigma - \theta)\Gamma(\tau - \theta)} \\ &= \sum_{p=0}^{\min\{m,n\}} \sum_{j=p}^n \frac{\Gamma(m - p + \sigma - \theta)\Gamma(j - p + \tau - \theta)}{(m-p)!(j-p)!\Gamma(\sigma - \theta)\Gamma(\tau - \theta)} \\ &= \sum_{p=0}^{\min\{m,n\}} \sum_{i=0}^{n-p} \frac{\Gamma(m - p + \sigma - \theta)\Gamma(i + \tau - \theta)}{(m-p)!i!\Gamma(\sigma - \theta)\Gamma(\tau - \theta)} \\ &= \sum_{p=0}^{\min\{m,n\}} \frac{\Gamma(m - p + \sigma - \theta)\Gamma(n - p + 1 + \tau - \theta)}{(m-p)!(n-p)!\Gamma(\sigma - \theta)\Gamma(1 + \tau - \theta)}. \quad \square \end{aligned}$$

**Proposition 4.4.10.** *If  $(\sigma, \tau, \theta)$  satisfies (1.10.8), then there exists  $\omega = \omega(\sigma, \tau, \theta) > 0$  so that, for  $k = 2m$  and  $\ell = 2n + 1$ ,*

$$|c'_{k,\ell}| \lesssim s^{\frac{1+v}{2}} (m+1)^{-\omega} (n+1)^{-\omega}.$$

*Proof.* Let  $p$  run from 0 to  $\min\{m, n\}$ . By Proposition 4.4.9 and Lemma 4.2.12,

$$\begin{aligned} |c'_{k,\ell}| &\lesssim s^{\frac{1+v}{2}} (m+1)^{\frac{1}{4}-\frac{\sigma}{2}} (n+1)^{-\frac{1}{4}-\frac{\tau}{2}} \\ &\times \sum_p (m-p+1)^{\sigma-\theta-1} (n-p+1)^{\tau-\theta} (p+1)^{\theta-\frac{1}{2}}. \end{aligned}$$

Then the result follows by Corollary 4.6.2, proved in Section 4.6, since  $(\sigma, \tau, \theta)$  satisfies (1.10.8).  $\square$

#### 4.4.6 Proof of Theorem 1.10.3

Assume the conditions of Theorem 1.10.3. Let  $j_{\sigma,\tau}$  be the positive definite symmetric sesquilinear form in  $L^2_{\sigma,\tau}$ , with domain  $\mathcal{S}$ , defined by  $j_{\sigma,\tau}(\phi, \psi) = \langle J_{\sigma,\tau}\phi, \psi \rangle_{\sigma,\tau}$ .

**Proposition 4.4.11.** *For any  $\epsilon > 0$ , there is some  $E = E(\epsilon, \sigma, \tau, \theta) > 0$  such that, for all  $\phi \in \mathcal{S}$ ,*

$$|\mathfrak{t}'(\phi)| \leq \epsilon s^{\frac{v-1}{2}} j_{\sigma,\tau}(\phi) + E s^{\frac{1+v}{2}} \|\phi\|_{\sigma,\tau}^2.$$

*Proof.* This follows from Propositions 4.4.2, 4.4.4, 4.4.6, 4.4.8 and 4.4.10 using the arguments of the proof of Proposition 4.2.17.  $\square$

*Proof of Theorem 1.10.3.* This is analogous to the proof of Theorem 1.10.1. Thus some details and the bibliographic references are omitted.

Let  $\mathfrak{t}_{\sigma,\tau}$  be the positive definite symmetric sesquilinear form in  $L^2_{\sigma,\tau}$ , with domain  $D(\mathfrak{t}_{\sigma,\tau}) = \mathcal{S}$ , defined by  $\mathfrak{t}_{\sigma}$  on  $\mathcal{S}_{\text{ev}}$  and  $\mathfrak{t}_{\tau}$  on  $\mathcal{S}_{\text{odd}}$ , and vanishing on  $\mathcal{S}_{\text{ev}} \times \mathcal{S}_{\text{odd}}$  (and therefore also on  $\mathcal{S}_{\text{odd}} \times \mathcal{S}_{\text{ev}}$ ). Let  $\mathfrak{s}$  be the symmetric sesquilinear form in  $L^2_{\sigma,\tau}$ , with  $D(\mathfrak{s}) = \mathcal{S}$ , defined by  $\mathfrak{s}(\phi, \psi) = \mathfrak{t}'(\phi, \psi) + \overline{\mathfrak{t}'(\psi, \phi)}$ . Then the symmetric sesquilinear form  $\mathfrak{v} = j_{\sigma,\tau} + \xi \mathfrak{t}_{\sigma,\tau} + \eta \mathfrak{s}$  in  $L^2_{\sigma,\tau}$ , with  $D(\mathfrak{v}) = \mathcal{S}$ , is given by the right hand side of (1.10.9). Using Propositions 4.2.17 and 4.4.11, for any  $\epsilon > 0$ , there are some  $C = C(\epsilon, \sigma, \tau, u) > 0$  and  $E = E(\epsilon, \sigma, \tau, \theta) > 0$  such that, for all  $\phi \in \mathcal{S}$ ,

$$\begin{aligned} &|(\xi \mathfrak{t}_{\sigma,\tau} + \eta \mathfrak{s})(\phi)| \\ &\leq \epsilon (\xi s^{u-1} + 2|\eta| s^{\frac{v-1}{2}}) j_{\sigma,\tau}(\phi) + (\xi C s^u + 2|\eta| E s^{\frac{1+v}{2}}) \|\phi\|_{\sigma,\tau}^2. \end{aligned} \quad (4.4.3)$$

Then, taking  $\epsilon$  so that  $\epsilon (\xi s^{u-1} + 2|\eta| s^{\frac{v-1}{2}}) < 1$ , since  $j_{\sigma,\tau}$  is closable and positive definite, it follows that  $\mathfrak{v}$  is sectorial and closable, and  $D(\overline{\mathfrak{v}}) = D(\overline{j_{\sigma,\tau}})$ ; in particular,  $\mathfrak{v}$

is bounded from below because it is also symmetric. So  $\bar{\mathfrak{v}}$  is induced by a self-adjoint operator  $\mathcal{V}$  in  $L^2_{\sigma,\tau}$  with  $D(\mathcal{V}^{1/2}) = D(\bar{\mathfrak{v}})$ . Thus  $\mathcal{S}$  is a core of  $\bar{\mathfrak{v}}$  and  $\mathcal{V}^{1/2}$ .

For all  $\phi \in \mathcal{S}$ ,

$$\mathfrak{v}(\phi) \geq \mathfrak{j}_{\sigma,\tau}(\phi) + \xi \mathfrak{t}_{\sigma,\tau}(\phi) - |\eta| \mathfrak{s}(\phi) \geq \mathfrak{j}_{\sigma,\tau}(\phi) + \xi \mathfrak{t}_{\sigma,\tau}(\phi) - 2|\eta| |\mathfrak{t}'(\phi)|. \quad (4.4.4)$$

Since  $\mathcal{S}$  is a core of  $\bar{\mathfrak{v}}$  and  $\overline{\mathfrak{j}_{\sigma,\tau}}$ , using Propositions 4.2.18 and 4.4.11 like in the proof of Theorem 1.10.1, it follows from (4.4.4) that  $\mathcal{V}$  has a discrete spectrum, which consists of two groups of eigenvalues,  $\lambda_0 \leq \lambda_2 \leq \dots$  and  $\lambda_1 \leq \lambda_3 \leq \dots$ , repeated according to their multiplicity, satisfying (1.10.10). On the other hand, by (4.4.3), for all  $\phi \in \mathcal{S}$ ,

$$\mathfrak{v}(\phi) \leq (1 + \epsilon(\xi s^{u-1} + 2|\eta| s^{\frac{v-1}{2}})) \mathfrak{j}_{\sigma,\tau}(\phi) + (\xi C s^u + 2|\eta| E s^{\frac{1+v}{2}}) \|\phi\|_{\sigma,\tau}^2, \quad (4.4.5)$$

obtaining (1.10.11) because  $\mathcal{S}$  is a core of  $\bar{\mathfrak{v}}$  and  $\overline{\mathfrak{j}_{\sigma,\tau}}$ .

With the notation of (iii), let  $\tilde{\mathfrak{t}}_\sigma$  (respectively,  $\tilde{\mathfrak{t}}_\tau$ ) be the symmetric sesquilinear form in  $L^2_\sigma$  (respectively,  $L^2_\tau$ ), with  $D(\tilde{\mathfrak{t}}_\sigma) = \mathcal{S}$  (respectively,  $D(\tilde{\mathfrak{t}}_\tau) = \mathcal{S}$ ), defined like  $\mathfrak{t}_\sigma$  (respectively,  $\mathfrak{t}_\tau$ ), using  $\tilde{u}$  (respectively,  $v - \tilde{u} + 1$ ) instead of  $u$ . Let  $\tilde{\mathfrak{t}}_{\sigma,\tau}$  be the positive definite symmetric sesquilinear form in  $L^2_{\sigma,\tau}$ , with  $D(\tilde{\mathfrak{t}}_{\sigma,\tau}) = \mathcal{S}$ , defined by  $\tilde{\mathfrak{t}}_\sigma$  on  $\mathcal{S}_{\text{ev}}$  and  $\tilde{\mathfrak{t}}_\tau$  on  $\mathcal{S}_{\text{odd}}$ , and vanishing on  $\mathcal{S}_{\text{ev}} \times \mathcal{S}_{\text{odd}}$ . By the Schwartz inequality, we deduce

$$\begin{aligned} 2|\mathfrak{t}'(\phi)| &= 2|\langle \phi_{\text{ev}} | x |^{-\tilde{u}+\sigma-\theta}, x^{-1} \phi_{\text{odd}} | x |^{\tilde{u}-\sigma+\theta} \rangle_\theta| \\ &\leq 2\|\phi_{\text{ev}} | x |^{-\tilde{u}+\sigma-\theta}\|_\theta \cdot \|\phi_{\text{odd}} | x |^{\tilde{u}-\sigma+\theta-1}\|_\theta \\ &= 2\|\phi_{\text{ev}} | x |^{-\tilde{u}}\|_\sigma \cdot \|\phi_{\text{odd}} | x |^{\tilde{u}-v-1}\|_\tau \\ &\leq \|\phi_{\text{ev}} | x |^{-\tilde{u}}\|_\sigma^2 + \|\phi_{\text{odd}} | x |^{\tilde{u}-v-1}\|_\tau^2 = \tilde{\mathfrak{t}}_{\sigma,\tau}(\phi). \end{aligned} \quad (4.4.6)$$

Hence (1.10.13) follows like in the proof of Theorem 1.10.1, using Propositions 4.2.17 and 4.2.18.

If  $u = \frac{v+1}{2}$ , then we can take  $\tilde{u} = u = v - \tilde{u} + 1$  in (iii), yielding

$$\mathfrak{v}(\phi) \geq \mathfrak{j}_{\sigma,\tau}(\phi) + (\xi - |\eta|) \mathfrak{t}_{\sigma,\tau}(\phi)$$

by (4.4.4) and (4.4.6). Thus (1.10.14) follows if  $|\eta| \leq \xi$ , like in the proof of Theorem 1.10.1, using Proposition 4.2.18.

If we add the term  $\xi' \langle \phi_{\text{ev}}, \psi_{\text{ev}} \rangle_\sigma + \xi'' \langle \phi_{\text{odd}}, \psi_{\text{odd}} \rangle_\tau$  to the right hand side of (1.10.9), for some  $\xi', \xi'' \in \mathbb{R}$ , then the same argument can be used by adding the term  $\xi' \|\phi_{\text{ev}}\|_\sigma^2 + \xi'' \|\phi_{\text{odd}}\|_\tau^2$  to  $\mathfrak{j}_{\sigma,\tau}$ , obtaining (v).  $\square$

## 4.5 A preliminary estimate

### 4.5.1 Statement

The standard coordinates of  $\mathbb{R}^5$  are denoted by  $(\alpha, \beta, \gamma, \delta, \varkappa)$ . Consider the partition of  $\mathbb{R}$  into the following intervals:  $I_1 = (-\infty, -1]$ ,  $I_2 = (-1, -\frac{1}{2}]$ ,  $I_3 = (-\frac{1}{2}, -\frac{1}{3}]$ ,  $I_4 = (-\frac{1}{3}, 0)$  and  $I_5 = [0, \infty)$ . Let  $Q_{ijk} = I_i \times I_j \times I_k$ , and consider the following subsets of  $\mathbb{R}^5$ :

$\mathfrak{S}_{515}$ : This is the subset of  $\mathbb{R}^2 \times Q_{515}$  defined by

$$\alpha + \gamma, \alpha + \beta + \gamma + \varkappa < 0. \quad (4.5.1)$$

$\mathfrak{S}_{522}$ : This is the subset of  $\mathbb{R}^2 \times Q_{522}$  defined by

$$\alpha + \gamma, \alpha + \beta + \gamma < 0. \quad (4.5.2)$$

$\mathfrak{S}_{252}$ : This is the subset of  $\mathbb{R}^2 \times Q_{252}$  defined by

$$0 \leq \gamma + \delta \Rightarrow \alpha + \gamma, \alpha + \beta + \gamma + \delta + \varkappa + 1 < 0, \quad (4.5.3)$$

$$\gamma + \delta < 0 \Rightarrow \begin{cases} \alpha + \gamma + \delta, \alpha + \beta + \varkappa + 1 < 0, \text{ or} \\ \alpha + \gamma + \frac{1}{2}, \alpha + \beta + \delta < 0, \text{ or} \\ \alpha + \gamma + \frac{1}{3}, \alpha + \beta + \delta + \frac{1}{3} < 0, \text{ or} \\ \alpha + \gamma, \alpha + \beta + \delta + \varkappa + 1 < 0. \end{cases} \quad (4.5.4)$$

$\mathfrak{S}_{155}$ : This is the subset of  $\mathbb{R}^2 \times Q_{155}$  defined by (4.5.3) and

$$\gamma + \delta < 0 \Rightarrow \begin{cases} \alpha + \gamma + \delta, \alpha + \beta + \varkappa + 1 < 0, \text{ or} \\ \alpha + \gamma + 1, \alpha + \beta + \delta + \varkappa < 0, \text{ or} \\ \alpha + \gamma + \frac{1}{2}, \alpha + \beta + \delta + \varkappa + \frac{1}{2} < 0, \text{ or} \\ \alpha + \gamma + \frac{1}{3}, \alpha + \beta + \delta + \varkappa + \frac{2}{3} < 0, \text{ or} \\ \alpha + \gamma, \alpha + \beta + \delta + \varkappa + 1 < 0. \end{cases} \quad (4.5.5)$$

$\mathfrak{S}_{212}$ : This is the subset of  $\mathbb{R}^2 \times Q_{212}$  defined by

$$\gamma \leq \varkappa \Rightarrow \alpha + \gamma, \alpha + \beta + \varkappa < 0, \quad (4.5.6)$$

$$\varkappa \leq \gamma \Rightarrow \alpha + \gamma, \alpha + \beta + \gamma < 0. \quad (4.5.7)$$

Let  $\check{\mathfrak{S}} = \mathfrak{S}_{515} \cup \mathfrak{S}_{522} \cup \mathfrak{S}_{252} \cup \mathfrak{S}_{155} \cup \mathfrak{S}_{212}$ . On the other hand, consider the linear isomorphism of  $\mathbb{R}^5$  defined by

$$(\alpha, \beta, \gamma, \delta, \varkappa) \mapsto (\beta, \alpha, \delta, \gamma, \varkappa). \quad (4.5.8)$$

This is the reflection with respect to the linear subspace defined by  $\alpha = \beta$  and  $\gamma = \delta$ . The image of any subset  $X \subset \mathbb{R}^5$  by the mapping (4.5.8) is denoted by  $X'$ , and let  $X_{\text{conv}}$  be the convex hull of  $X$ . Thus  $X'_{\text{conv}} := (X')_{\text{conv}} = (X_{\text{conv}})'$ .

**Lemma 4.5.1.** *If  $(\alpha, \beta, \gamma, \delta, \varkappa) \in \check{\mathfrak{S}}_{\text{conv}} \cap \check{\mathfrak{S}}'_{\text{conv}}$ , then there is some  $\omega > 0$  such that, for all  $m, n \in \mathbb{N}$ ,*

$$(m+1)^\alpha (n+1)^\beta \sum_{p=0}^{\min\{m,n\}} (m-p+1)^\gamma (n-p+1)^\delta (p+1)^\varkappa \asymp (m+1)^{-\omega} (n+1)^{-\omega}. \quad (4.5.9)$$

### 4.5.2 Proof of Lemma 4.5.1

Since the roles of  $m$  and  $n$  in Lemma 4.5.1 are interchanged by the mapping (4.5.8), we can assume that  $m \geq n$ . Then Lemma 4.2.14 gives (4.5.9) once

$$\sum_{p=0}^n (m-p+1)^\gamma (n-p+1)^\delta (p+1)^\varkappa$$

is appropriately estimated. Estimates of this expression are achieved with several strategies explained in Sections 4.5.2–4.5.2, giving rise to several lists of conditions that guarantee (4.5.9) when  $m \geq n$ . Then, for the chosen subindices  $ijk$  equal to 515, 522, 252, 155, 212, every  $\mathfrak{S}_{ijk}$  is defined by the most general of those conditions on  $\mathbb{R}^2 \times Q_{ijk}$ . This will show that (4.5.9) holds for  $m \geq n$  and  $(\alpha, \beta, \gamma, \delta, \varkappa) \in \check{\mathfrak{S}}$ . In Section 4.5.2, it will be shown that this property can be extended to the convex hull  $\check{\mathfrak{S}}_{\text{conv}}$ , completing the proof of Lemma 4.5.1.

#### First list of conditions

For all  $\epsilon > 0$ ,

$$\begin{aligned} \sum_{p=0}^n (p+1)^\varkappa &= \sum_{q=1}^{n+1} q^\varkappa \leq \begin{cases} \int_1^{n+2} x^\varkappa dx & \text{if } \varkappa \geq 0 \\ 1 + \int_1^{n+1} x^\varkappa dx & \text{if } \varkappa < 0 \end{cases} \\ &\asymp \begin{cases} (n+1)^{\varkappa+1} & \text{if } \varkappa > -1 \\ 1 + \ln(n+1) & \text{if } \varkappa = -1 \\ 1 & \text{if } \varkappa < -1 \end{cases} \asymp \begin{cases} (n+1)^{\varkappa+1} & \text{if } \varkappa > -1 \\ (n+1)^\epsilon & \text{if } \varkappa = -1 \\ 1 & \text{if } \varkappa < -1. \end{cases} \end{aligned} \quad (4.5.10)$$

On the other hand, we claim that

$$(m-p+1)^\gamma(n-p+1)^\delta \preceq \left\{ \begin{array}{ll} (m+1)^\gamma(n+1)^\delta & \text{if } \delta \geq -\gamma, 0 \\ (m-n+1)^{\gamma+\delta} \text{ and } (m-n+1)^\gamma(n+1)^\delta & \text{if } 0 \leq \delta < -\gamma \\ (m-n+1)^\gamma & \text{if } \delta \leq -\gamma, 0 \\ (m-n+1)^\gamma \text{ or } (m+1)^\gamma(n+1)^\delta & \text{if } -\gamma < \delta < 0 \end{array} \right\} \quad (4.5.11)$$

for all  $p = 0, \dots, n$ . Combining (4.5.10) and (4.5.11), it follows that

$$(m+1)^\alpha(n+1)^\beta \sum_{p=0}^n (m-p+1)^\gamma(n-p+1)^\delta(p+1)^\varkappa \preceq A_1, \quad (4.5.12)$$

where  $A_1 = A_1(m, n, \alpha, \beta, \gamma, \delta, \varkappa)$  can be taken to be equal to:

$$\left. \begin{array}{ll} (m+1)^{\alpha+\gamma}(n+1)^{\beta+\delta+\varkappa+1} & \text{if } -\gamma, 0 \leq \delta, -1 < \varkappa, \\ (m+1)^\alpha(n+1)^{\beta+\varkappa+1}(m-n+1)^{\gamma+\delta} \text{ and } (m+1)^\alpha(n+1)^{\beta+\delta+\varkappa+1}(m-n+1)^\gamma & \text{if } 0 \leq \delta < -\gamma, -1 < \varkappa. \end{array} \right\}$$

In the definition of  $A_1$ , the other cases of  $\gamma, \delta, \varkappa$  are omitted because they will not be used. We will continue omitting such cases, often without further comment. Resulting tautologies will be also removed without further comment. By (4.5.12), applying Lemma 4.2.14 to the above list, we get the first list of conditions that guarantee (4.5.9) when  $m \geq n$ :

$$-\gamma, 0 \leq \delta, -1 < \varkappa \Rightarrow \alpha + \gamma, \alpha + \beta + \gamma + \delta + \varkappa + 1 < 0, \quad (4.5.13)$$

$$0 \leq \delta < -\gamma, -1 < \varkappa \Rightarrow \left\{ \begin{array}{l} \alpha + \gamma + \delta, \alpha + \beta + \varkappa + 1 < 0, \text{ or} \\ \alpha + \gamma, \alpha + \beta + \delta + \varkappa + 1 < 0. \end{array} \right. \quad (4.5.14)$$

To prove (4.5.11), it is enough to study the maximum of the  $C^\infty$  function

$$f(x) = (m-x+1)^\gamma(n-x+1)^\delta$$

on  $[0, n]$  (the natural domain of  $f$  contains  $(-\infty, n+1)$ ). We have

$$f'(x) = (m-x+1)^{\gamma-1}(n-x+1)^{\delta-1}h(x),$$

where

$$h(x) = (\gamma + \delta)x - \gamma(n+1) - \delta(m+1).$$

Observe that this expression is valid even when  $\gamma = 0$  or  $\delta = 0$ . Since  $f'$  and  $h$  have the same zero set on  $[0, n]$ , and they have the same sign on the complement of the zero set in  $[0, n]$ , it is enough to analyze  $h$  to know where  $f$  reaches its maximum on  $[0, n]$ . We consider several cases.

*Case where  $\gamma + \delta = 0$ .* Then  $h \equiv \gamma(m - n)$ . If  $m > n$  and  $\gamma \neq 0$ , then  $h \neq 0$  and  $\text{sign } h = \text{sign } \gamma$ . If  $m = n$  or  $\gamma = 0$ , then  $h \equiv 0$ . Hence:

$$\max_{0 \leq x \leq n} f(x) = \begin{cases} f(n) = (m - n + 1)^\gamma & \text{if } \gamma = -\delta \geq 0 \\ f(0) = (m + 1)^\gamma (n + 1)^\delta & \text{if } \gamma = -\delta \leq 0. \end{cases} \quad (4.5.15)$$

*Case where  $\gamma + \delta \neq 0$ .* Then  $h$  vanishes just at the point

$$x_0 := \frac{\gamma(n + 1) + \delta(m + 1)}{\gamma + \delta}.$$

*Case where  $\gamma + \delta < 0$ .* We have  $h > 0$  on  $(-\infty, x_0)$  and  $h < 0$  on  $(x_0, \infty)$ , yielding

$$\max_{0 \leq x \leq n} f(x) = \begin{cases} f(0) = (m + 1)^\gamma (n + 1)^\delta & \text{if } x_0 \leq 0 \\ f(x_0) & \text{if } 0 \leq x_0 \leq n \\ f(n) = (m - n + 1)^\gamma & \text{if } x_0 \geq n. \end{cases} \quad (4.5.16)$$

*Case where  $\gamma + \delta < 0$  and  $\delta \leq 0$ .* Then  $x_0 \geq n + 1$ , and therefore, by (4.5.16),

$$\gamma + \delta < 0, \delta \leq 0 \Rightarrow \max_{0 \leq x \leq n} f(x) = (m - n + 1)^\gamma. \quad (4.5.17)$$

*Case where  $\gamma + \delta < 0$  and  $\delta > 0$ ; i.e.,  $0 < \delta < -\gamma$ .* We may have  $x_0 \leq 0$ ,  $0 \leq x_0 \leq n$  or  $n \leq x_0$ . Moreover

$$f(x_0) = \frac{(-\gamma)^\gamma \delta^\delta}{(-\gamma - \delta)^{\gamma + \delta}} (m - n)^{\gamma + \delta} \preccurlyeq (m - n + 1)^{\gamma + \delta}.$$

Therefore

$$0 < \delta < -\gamma \Rightarrow \max_{0 \leq x \leq n} f(x) \preccurlyeq (m - n + 1)^{\gamma + \delta} \quad (4.5.18)$$

by (4.5.16) and since

$$(m - n + 1)^\gamma, (m + 1)^\gamma (n + 1)^\delta < (m - n + 1)^{\gamma + \delta},$$

which follows using that  $\gamma < \gamma + \delta$  and

$$\begin{aligned} n \geq \frac{m}{2} &\Rightarrow \frac{m - n + 1}{n + 1} \leq 1 \Rightarrow \frac{m - n + 1}{m + 1} < \frac{m - n + 1}{n + 1} \leq \left(\frac{m - n + 1}{n + 1}\right)^{-\frac{\delta}{\gamma}}, \\ n < \frac{m}{2} &\Rightarrow \frac{m - n + 1}{n + 1} > 1 \Rightarrow \frac{m - n + 1}{m + 1} \leq 1 < \left(\frac{m - n + 1}{n + 1}\right)^{-\frac{\delta}{\gamma}}, \end{aligned}$$

because  $0 < -\frac{\delta}{\gamma} < 1$ . On the other hand, in this case,

$$\begin{aligned} \max_{0 \leq x \leq n} f(x) &\leq \max_{0 \leq x \leq n} (m-x+1)^\gamma \max_{0 \leq y \leq n} (n-y+1)^\delta \\ &= (m-n+1)^\gamma (n+1)^\delta < (m-n+1)^{\gamma+\delta} \end{aligned}$$

if  $n < \frac{m}{2}$ . So (4.5.18) can be improved by

$$0 < \delta < -\gamma \Rightarrow \max_{0 \leq x \leq n} f(x) \preceq \begin{cases} (m-n+1)^{\gamma+\delta} & \text{and} \\ (m-n+1)^\gamma (n+1)^\delta. \end{cases} \quad (4.5.19)$$

*Case where  $\gamma + \delta > 0$ .* We have  $h < 0$  on  $(-\infty, x_0)$  and  $h > 0$  on  $(x_0, \infty)$ , yielding

$$\max_{0 \leq x \leq n} f(x) = \begin{cases} f(n) = (m-n+1)^\gamma & \text{if } x_0 \leq 0 \\ \max\{f(0), f(n)\} & \text{if } 0 \leq x_0 \leq n \\ f(0) = (m+1)^\gamma (n+1)^\delta & \text{if } x_0 \geq n. \end{cases} \quad (4.5.20)$$

*Case where  $\gamma + \delta > 0$  and  $\delta \geq 0$ .* We get  $x_0 \geq n+1$ , and therefore, by (4.5.20),

$$\gamma + \delta > 0, \delta \geq 0 \Rightarrow \max_{0 \leq x \leq n} f(x) = (m+1)^\gamma (n+1)^\delta. \quad (4.5.21)$$

Gathering together (4.5.15), (4.5.17), (4.5.19) and (4.5.21), we get the first two cases of (4.5.11). The other cases will not be used, and they follow with similar arguments.

### Second list of conditions

According to (4.5.10), for all  $\epsilon > 0$ ,

$$\sum_{p=0}^n (n-p+1)^\delta = \sum_{q=1}^{n+1} q^\delta \preceq \begin{cases} (n+1)^{\delta+1} & \text{if } \delta > -1 \\ (n+1)^\epsilon & \text{if } \delta = -1 \\ 1 & \text{if } \delta < -1. \end{cases} \quad (4.5.22)$$

On the other hand, we claim that

$$(m-p+1)^\gamma (p+1)^\varkappa \leq \begin{cases} (m+1)^\gamma (n+1)^\varkappa & \text{if } \gamma, \varkappa \geq 0 \\ (m-n+1)^\gamma (n+1)^\varkappa & \text{if } \gamma \leq 0 \leq \varkappa \\ (m-n+1)^\gamma (n+1)^\varkappa \text{ or } \\ (m+1)^\gamma & \text{if } \gamma < \varkappa < 0 \\ (m+1)^\gamma & \text{if } \varkappa \leq \gamma, 0 \end{cases} \quad (4.5.23)$$

for all  $p = 0, \dots, n$ . Combining (4.5.22) and (4.5.23), it follows that, for all  $\epsilon > 0$ ,

$$(m+1)^\alpha(n+1)^\beta \sum_{p=0}^n (m-p+1)^\gamma(n-p+1)^\delta(p+1)^\varkappa \preceq A_2, \quad (4.5.24)$$

where  $A_2 = A_2(m, n, \alpha, \beta, \gamma, \delta, \varkappa, \epsilon)$  can be taken to be equal to:

$$\begin{array}{ll} (m+1)^{\alpha+\gamma}(n+1)^{\beta+\varkappa+\epsilon} & \text{if } 0 \leq \gamma, \varkappa, \delta = -1, \\ (m+1)^{\alpha+\gamma}(n+1)^{\beta+\varkappa} & \text{if } 0 \leq \gamma, \varkappa, \delta < -1, \\ (m+1)^\alpha(n+1)^{\beta+\varkappa+\epsilon}(m-n+1)^\gamma & \text{if } \gamma \leq 0 \leq \varkappa, \delta = -1, \\ (m+1)^\alpha(n+1)^{\beta+\varkappa}(m-n+1)^\gamma & \text{if } \gamma \leq 0 \leq \varkappa, \delta < -1, \\ \left. \begin{array}{l} (m+1)^\alpha(n+1)^{\beta+\varkappa+\epsilon}(m-n+1)^\gamma \text{ or} \\ (m+1)^{\alpha+\gamma}(n+1)^{\beta+\epsilon} \end{array} \right\} & \text{if } \gamma < \varkappa < 0, \delta = -1, \\ \left. \begin{array}{l} (m+1)^\alpha(n+1)^{\beta+\varkappa}(m-n+1)^\gamma \text{ or} \\ (m+1)^{\alpha+\gamma}(n+1)^\beta \end{array} \right\} & \text{if } \gamma < \varkappa < 0, \delta < -1, \\ (m+1)^{\alpha+\gamma}(n+1)^{\beta+\epsilon} & \text{if } \varkappa \leq \gamma, 0, \delta = -1, \\ (m+1)^{\alpha+\gamma}(n+1)^\beta & \text{if } \varkappa \leq \gamma, 0, \delta < -1. \end{array}$$

By (4.5.24), applying Lemma 4.2.14 to the above list, we get the second list of conditions that guarantee (4.5.9) when  $m \geq n$ :

$$0 \leq \gamma, \varkappa, \delta \leq -1 \Rightarrow \alpha + \gamma, \alpha + \beta + \gamma + \varkappa < 0, \quad (4.5.25)$$

$$\gamma \leq \varkappa, 0, \delta \leq -1 \Rightarrow \alpha + \gamma, \alpha + \beta + \varkappa < 0, \quad (4.5.26)$$

$$\varkappa \leq \gamma, 0, \delta \leq -1 \Rightarrow \alpha + \gamma, \alpha + \beta + \gamma < 0. \quad (4.5.27)$$

To prove (4.5.23), it is enough to study the maximum of the  $C^\infty$  function

$$f(x) = (m-x+1)^\gamma(x+1)^\varkappa$$

on  $[0, n]$  (the natural domain of  $f$  contains  $(-1, m+1)$ ). We have

$$f'(x) = (m-x+1)^{\gamma-1}(x+1)^{\varkappa-1}h(x),$$

where

$$h(x) = -(\gamma + \varkappa)x + \varkappa(m+1) - \gamma.$$

Observe that this expression is valid even when  $\gamma = 0$  or  $\varkappa = 0$ . Since  $f'$  and  $h$  have the same zero set on  $[0, n]$ , and they have the same sign on the complement of the

zero set in  $[0, n]$ , it is enough to analyze  $h$  to know where  $f$  reaches its maximum on  $[0, n]$ . We consider several cases.

*Case where  $\gamma + \varkappa = 0$ .* Then  $h \equiv \varkappa(m + 2)$ . If  $\varkappa \neq 0$ , then  $h \neq 0$  and  $\text{sign } h = \text{sign } \varkappa$ . If  $\varkappa = 0$ , then  $h \equiv 0$ . Hence:

$$\max_{0 \leq x \leq n} f(x) = \begin{cases} f(n) = (m - n + 1)^\gamma (n + 1)^\varkappa & \text{if } \varkappa = -\gamma \geq 0 \\ f(0) = (m + 1)^\gamma & \text{if } \varkappa = -\gamma \leq 0. \end{cases} \quad (4.5.28)$$

*Case where  $\gamma + \varkappa \neq 0$ .* Then  $h$  vanishes just at the point

$$x_0 := \frac{\varkappa(m + 1) - \gamma}{\gamma + \varkappa}.$$

*Case where  $\gamma + \varkappa < 0$ .* We have  $h < 0$  on  $(-\infty, x_0)$  and  $h > 0$  on  $(x_0, \infty)$ , yielding

$$\max_{0 \leq x \leq n} f(x) = \begin{cases} f(n) = (m - n + 1)^\gamma (n + 1)^\varkappa & \text{if } x_0 \leq 0 \\ \max\{f(0), f(n)\} & \text{if } 0 \leq x_0 \leq n \\ f(0) = (m + 1)^\gamma & \text{if } x_0 \geq n. \end{cases} \quad (4.5.29)$$

*Case where  $\gamma + \varkappa < 0$  and  $\varkappa \geq 0$ ; i.e.,  $0 \leq \varkappa < -\gamma$ .* Then  $x_0 < 0$ , and therefore, by (4.5.29),

$$0 \leq \varkappa < -\gamma \Rightarrow \max_{0 \leq x \leq n} f(x) = (m - n + 1)^\gamma (n + 1)^\varkappa. \quad (4.5.30)$$

*Case where  $\gamma + \varkappa < 0$  and  $\gamma \geq 0$ ; i.e.,  $0 \leq \gamma < -\varkappa$ .* Then  $x_0 \geq m + 1$ , and therefore, by (4.5.29),

$$0 \leq \gamma < -\varkappa \Rightarrow \max_{0 \leq x \leq n} f(x) = (m + 1)^\gamma. \quad (4.5.31)$$

*Case where  $\varkappa \leq \gamma < 0$ .* Then  $x_0 \geq \frac{m}{2}$ , and we may have  $x_0 \leq n$  or  $x_0 \geq n$ . In any case, by (4.5.29),

$$\varkappa \leq \gamma < 0 \Rightarrow \max_{0 \leq x \leq n} f(x) = (m + 1)^\gamma. \quad (4.5.32)$$

*Case where  $\gamma < \varkappa < 0$ .* Then  $x_0 < \frac{m}{2}$ , and we may have  $x_0 \leq 0$ ,  $0 \leq x_0 \leq n$  or  $x_0 \geq n$ . In any case, by (4.5.29),

$$\gamma < \varkappa < 0 \Rightarrow \max_{0 \leq x \leq n} f(x) = \begin{cases} (m - n + 1)^\gamma (n + 1)^\varkappa & \text{or} \\ (m + 1)^\gamma. \end{cases} \quad (4.5.33)$$

Case where  $\gamma + \varkappa > 0$ . We have  $h > 0$  on  $(-\infty, x_0)$  and  $h < 0$  on  $(x_0, \infty)$ , yielding

$$\max_{0 \leq x \leq n} f(x) = \begin{cases} f(0) = (m+1)^\gamma & \text{if } x_0 \leq 0 \\ f(x_0) & \text{if } 0 \leq x_0 \leq n \\ f(n) = (m-n+1)^\gamma(n+1)^\varkappa & \text{if } x_0 \geq n. \end{cases} \quad (4.5.34)$$

Case where  $\gamma + \varkappa > 0$  and  $\varkappa \leq 0$ ; i.e.,  $-\gamma < \varkappa \leq 0$ . Then  $x_0 < 0$ , and therefore, by (4.5.34),

$$-\gamma < \varkappa \leq 0 \Rightarrow \max_{0 \leq x \leq n} f(x) = (m+1)^\gamma. \quad (4.5.35)$$

Case where  $\gamma + \varkappa > 0$  and  $\gamma \leq 0$ ; i.e.,  $-\varkappa < \gamma \leq 0$ . Then  $x_0 \geq m+1$ , and therefore, by (4.5.34),

$$-\varkappa < \gamma \leq 0 \Rightarrow \max_{0 \leq x \leq n} f(x) = (m-n+1)^\gamma(n+1)^\varkappa. \quad (4.5.36)$$

Case where  $\gamma + \varkappa > 0$  and  $\gamma, \varkappa \geq 0$ . We may have  $x_0 \leq 0$ ,  $0 \leq x_0 \leq n$  or  $n \leq x_0$ . Moreover

$$f(x_0) = \frac{\gamma^\gamma \varkappa^\varkappa}{(\gamma + \varkappa)^{\gamma + \varkappa}} (m+2)^{\gamma + \varkappa} \preceq (m+1)^{\gamma + \varkappa}.$$

But, in this case,

$$\begin{aligned} \max_{0 \leq x \leq n} f(x) &\leq \max_{0 \leq x \leq n} (m-x+1)^\gamma \max_{0 \leq y \leq n} (y+1)^\varkappa \\ &= (m+1)^\gamma(n+1)^\varkappa \leq (m+1)^{\gamma + \varkappa}. \end{aligned}$$

Therefore, by (4.5.34),

$$\gamma, \varkappa \geq 0 \Rightarrow \max_{0 \leq x \leq n} f(x) \leq (m+1)^\gamma(n+1)^\varkappa. \quad (4.5.37)$$

Gathering together (4.5.28), (4.5.30)–(4.5.33) and (4.5.35)–(4.5.37), we get (4.5.23).

### Third list of conditions

For all  $\epsilon > 0$ ,

$$\begin{aligned} \sum_{p=0}^n (m-p+1)^\gamma &= \sum_{q=m-n+1}^{m+1} q^\gamma \leq \begin{cases} \int_{m-n+1}^{m+2} x^\gamma dx & \text{if } \gamma \geq 0 \\ (m-n+1)^\gamma + \int_{m-n+1}^{m+1} x^\gamma dx & \text{if } \gamma < 0 \end{cases} \\ &\preceq \begin{cases} (m+1)^{\gamma+1} & \text{if } \gamma > -1 \\ 1 + \ln(m+1) & \text{if } \gamma = -1 \\ (m-n+1)^{\gamma+1} & \text{if } \gamma < -1 \end{cases} \preceq \begin{cases} (m+1)^{\gamma+1} & \text{if } \gamma > -1 \\ (m+1)^\epsilon & \text{if } \gamma = -1 \\ (m-n+1)^{\gamma+1} & \text{if } \gamma < -1. \end{cases} \quad (4.5.38) \end{aligned}$$

The following gives a better estimate when  $\gamma \geq 0$ , and an alternative estimate when  $\gamma < 0$ :

$$\sum_{p=0}^n (m-p+1)^\gamma \leq \begin{cases} (m+1)^\gamma (n+1) & \text{if } \gamma \geq 0 \\ (m-n+1)^\gamma (n+1) & \text{if } \gamma < 0. \end{cases} \quad (4.5.39)$$

The estimate (4.5.39) is better than (4.5.38) when  $\gamma \geq 0$  since  $m \geq n$ , and (4.5.39) may be better or worse than (4.5.38) when  $\gamma < 0$ , depending on the values of  $m$  and  $n$ . Note that estimates of the type (4.5.39) for  $\sum_{p=0}^n (p+1)^\varkappa$  and  $\sum_{p=0}^n (n-p+1)^\delta$  are worse than (4.5.10) and (4.5.22). Thus it makes no sense to add this kind of estimate in Sections 4.5.2 and 4.5.2. On the other hand, we claim that

$$(n-p+1)^\delta (p+1)^\varkappa \leq \begin{cases} (n+1)^\varkappa & \text{if } \delta \leq \varkappa, 0 \\ (n+1)^{\delta+\varkappa} & \text{if } \delta, \varkappa \geq 0 \\ (n+1)^\delta & \text{if } \varkappa \leq \delta, 0 \end{cases} \quad (4.5.40)$$

for all  $p = 0, \dots, n$ . Combining (4.5.38)–(4.5.40), it follows that, for all  $\epsilon > 0$ ,

$$(m+1)^\alpha (n+1)^\beta \sum_{p=0}^n (m-p+1)^\gamma (n-p+1)^\delta (p+1)^\varkappa \preceq A_3, \quad (4.5.41)$$

where  $A_3 = A_3(m, n, \alpha, \beta, \gamma, \delta, \varkappa, \epsilon)$  can be taken to be equal to:

$$\left. \begin{aligned} & (m+1)^{\alpha+\epsilon} (n+1)^{\beta+\delta+\varkappa} \text{ and} \\ & (m+1)^\alpha (n+1)^{\beta+\delta+\varkappa+1} (m-n+1)^\gamma \end{aligned} \right\} \quad \text{if } \gamma = -1, 0 \leq \delta, \varkappa,$$

$$\left. \begin{aligned} & (m+1)^\alpha (n+1)^{\beta+\delta+\varkappa} (m-n+1)^{\gamma+1} \text{ and} \\ & (m+1)^\alpha (n+1)^{\beta+\delta+\varkappa+1} (m-n+1)^\gamma \end{aligned} \right\} \quad \text{if } \gamma < -1, 0 \leq \delta, \varkappa.$$

By (4.5.41), applying Lemma 4.2.14 to the above list, we get the third list of conditions that guarantee (4.5.9) when  $m \geq n$ :

$$\gamma \leq -1, 0 \leq \delta, \varkappa \Rightarrow \begin{cases} \alpha + \gamma + 1, \alpha + \beta + \delta + \varkappa < 0, \text{ or} \\ \alpha + \gamma, \alpha + \beta + \delta + \varkappa + 1 < 0. \end{cases} \quad (4.5.42)$$

To prove (4.5.40), it is enough to study the maximum of the  $C^\infty$  function

$$f(x) = (n-x+1)^\delta (x+1)^\varkappa$$

on  $[0, n]$  (the natural domain of  $f$  contains  $(-1, n+1)$ ). We have

$$f'(x) = (n-x+1)^{\delta-1} (x+1)^{\varkappa-1} h(x),$$

where

$$h(x) = -(\delta + \varkappa)x + \varkappa(n + 1) - \delta.$$

Observe that this expression is valid even when  $\delta = 0$  or  $\varkappa = 0$ . Since  $f'$  and  $h$  have the same zero set on  $[0, n]$ , and they have the same sign on the complement of the zero set in  $[0, n]$ , it is enough to analyze  $h$  to know where  $f$  reaches its maximum on  $[0, n]$ . We consider several cases.

*Case where  $\delta + \varkappa = 0$ .* Then  $h \equiv \varkappa(n + 2)$ . If  $\varkappa \neq 0$ , then  $h \neq 0$  and sign  $h = \text{sign } \varkappa$ . If  $\varkappa = 0$ , then  $h \equiv 0$ . Hence:

$$\max_{0 \leq x \leq n} f(x) = \begin{cases} f(n) = (n + 1)^\varkappa & \text{if } \varkappa = -\delta \geq 0 \\ f(0) = (n + 1)^\delta & \text{if } \varkappa = -\delta \leq 0. \end{cases} \quad (4.5.43)$$

*Case where  $\delta + \varkappa \neq 0$ .* Then  $h$  vanishes just at the point

$$x_0 := \frac{\varkappa(n + 1) - \delta}{\delta + \varkappa}.$$

*Case where  $\delta + \varkappa > 0$ .* We have  $h > 0$  on  $(-\infty, x_0)$  and  $h < 0$  on  $(x_0, \infty)$ , yielding

$$\max_{0 \leq x \leq n} f(x) = \begin{cases} f(0) = (n + 1)^\delta & \text{if } x_0 \leq 0 \\ f(x_0) & \text{if } 0 \leq x_0 \leq n \\ f(n) = (n + 1)^\varkappa & \text{if } x_0 \geq n. \end{cases} \quad (4.5.44)$$

*Case where  $\delta + \varkappa > 0$  and  $\delta, \varkappa \geq 0$ .* We may have  $x_0 \leq 0$ ,  $0 \leq x_0 \leq n$  or  $n \leq x_0$ . Moreover

$$f(x_0) = \frac{\delta^\delta \varkappa^\varkappa}{(\delta + \varkappa)^{\delta + \varkappa}} (n + 2)^{\delta + \varkappa} \leq (n + 1)^{\delta + \varkappa}.$$

But, in this case,

$$\max_{0 \leq x \leq n} f(x) \leq \max_{0 \leq x \leq n} (n - x + 1)^\delta \max_{0 \leq y \leq n} (y + 1)^\varkappa = (n + 1)^{\delta + \varkappa}.$$

Therefore, by (4.5.44),

$$\delta, \varkappa \geq 0 \Rightarrow \max_{0 \leq x \leq n} f(x) \leq (n + 1)^{\delta + \varkappa}. \quad (4.5.45)$$

Gathering together (4.5.43) and (4.5.45), we get the second case of (4.5.40). The other cases will not be used, and they follow with similar arguments.

**Fourth list of conditions**

We have

$$(p + 1)^\varkappa \leq \begin{cases} (n + 1)^\varkappa & \text{if } \varkappa \geq 0 \\ 1 & \text{if } \varkappa \leq 0 \end{cases} \tag{4.5.46}$$

for  $p = 0, \dots, n$ . Moreover, by (4.5.10), (4.5.38) and (4.5.39), for all  $\epsilon > 0$ ,

$$\sum_{p=0}^n (n - p + 1)^{2\delta} = \sum_{q=1}^{n+1} q^{2\delta} \preccurlyeq \begin{cases} (n + 1)^{2\delta+1} & \text{if } \delta > -\frac{1}{2} \\ (n + 1)^\epsilon & \text{if } \delta = -\frac{1}{2} \\ 1 & \text{if } \delta < -\frac{1}{2}, \end{cases} \tag{4.5.47}$$

$$\sum_{p=0}^n (m - p + 1)^{2\gamma} \preccurlyeq \begin{cases} (m + 1)^{2\gamma+1} & \text{if } \gamma > -\frac{1}{2} \\ (m + 1)^\epsilon & \text{if } \gamma = -\frac{1}{2} \\ (m - n + 1)^{2\gamma+1} & \text{if } \gamma < -\frac{1}{2}, \end{cases} \tag{4.5.48}$$

$$\sum_{p=0}^n (m - p + 1)^{2\gamma} \leq \begin{cases} (m + 1)^{2\gamma}(n + 1) & \text{if } \gamma \geq 0 \\ (m - n + 1)^{2\gamma}(n + 1) & \text{if } \gamma < 0. \end{cases} \tag{4.5.49}$$

The estimate (4.5.49) is better than (4.5.48) when  $\gamma \geq 0$ , and it may be better or worse than (4.5.48) when  $\gamma < 0$ , depending on the values of  $m$  and  $n$ . By the Cauchy-Schwartz inequality,

$$\sum_{p=0}^n (m - p + 1)^\gamma (n - p + 1)^\delta \leq \left( \sum_{p=0}^n (m - p + 1)^{2\gamma} \right)^{\frac{1}{2}} \left( \sum_{p=0}^n (n - p + 1)^{2\delta} \right)^{\frac{1}{2}}.$$

Therefore, by (4.5.46)–(4.5.49),

$$(m + 1)^\alpha (n + 1)^\beta \sum_{p=0}^n (m - p + 1)^\gamma (n - p + 1)^\delta (p + 1)^\varkappa \preccurlyeq A_4, \tag{4.5.50}$$

where  $A_4 = A_4(m, n, \alpha, \beta, \gamma, \delta, \varkappa)$  can be taken to be equal to:

$$\left. \begin{aligned} &(m + 1)^\alpha (n + 1)^{\beta+\delta+\varkappa+\frac{1}{2}} (m - n + 1)^{\gamma+\frac{1}{2}} \text{ and } \\ &(m + 1)^\alpha (n + 1)^{\beta+\delta+\varkappa+1} (m - n + 1)^\gamma \end{aligned} \right\} \text{ if } \gamma < -\frac{1}{2} < \delta, 0 \leq \varkappa.$$

By (4.5.50), applying Lemma 4.2.14 to the above list, we get the fourth list of conditions that guarantee (4.5.9) when  $m \geq n$ :

$$\gamma < -\frac{1}{2} < \delta, 0 \leq \varkappa \Rightarrow \begin{cases} \alpha + \gamma + \frac{1}{2}, \alpha + \beta + \delta + \varkappa + \frac{1}{2} < 0, \text{ or} \\ \alpha + \gamma, \alpha + \beta + \delta + \varkappa + 1 < 0. \end{cases} \tag{4.5.51}$$

**Fifth list of conditions**

This is analogous to the estimates of Section 4.5.2, interchanging the roles of  $\delta$  and  $\varkappa$ . We have

$$(n - p + 1)^\delta \leq \begin{cases} (n + 1)^\delta & \text{if } \delta \geq 0 \\ 1 & \text{if } \delta \leq 0 \end{cases} \quad (4.5.52)$$

for  $p = 0, \dots, n$ . Moreover, by (4.5.10), for all  $\epsilon > 0$ ,

$$\sum_{p=0}^n (p + 1)^{2\varkappa} \preccurlyeq \begin{cases} (n + 1)^{2\varkappa+1} & \text{if } \varkappa > -\frac{1}{2} \\ (n + 1)^\epsilon & \text{if } \varkappa = -\frac{1}{2} \\ 1 & \text{if } \varkappa < -\frac{1}{2}. \end{cases} \quad (4.5.53)$$

Applying the Cauchy-Schwartz inequality, we get

$$\sum_{p=0}^n (m - p + 1)^\gamma (p + 1)^\varkappa \leq \left( \sum_{p=0}^n (m - p + 1)^{2\gamma} \right)^{\frac{1}{2}} \left( \sum_{p=0}^n (p + 1)^{2\varkappa} \right)^{\frac{1}{2}}.$$

Therefore, by (4.5.52), (4.5.53), (4.5.48) and (4.5.49), for all  $\epsilon > 0$ ,

$$(m + 1)^\alpha (n + 1)^\beta \sum_{p=0}^n (m - p + 1)^\gamma (n - p + 1)^\delta (p + 1)^\varkappa \preccurlyeq A_5, \quad (4.5.54)$$

where  $A_5 = A_5(m, n, \alpha, \beta, \gamma, \delta, \varkappa, \epsilon)$  can be taken to be equal to:

$$\left. \begin{aligned} & (m + 1)^{\alpha+\epsilon} (n + 1)^{\beta+\delta+\epsilon} \text{ and} \\ & (m + 1)^\alpha (n + 1)^{\beta+\delta+\frac{1}{2}+\epsilon} (m - n + 1)^\gamma \end{aligned} \right\} \quad \text{if } \gamma = \varkappa = -\frac{1}{2}, 0 \leq \delta,$$

$$\left. \begin{aligned} & (m + 1)^{\alpha+\epsilon} (n + 1)^{\beta+\delta} \text{ and} \\ & (m + 1)^\alpha (n + 1)^{\beta+\delta+\frac{1}{2}} (m - n + 1)^\gamma \end{aligned} \right\} \quad \text{if } \varkappa < \gamma = -\frac{1}{2}, 0 \leq \delta,$$

$$\left. \begin{aligned} & (m + 1)^\alpha (n + 1)^{\beta+\delta+\epsilon} (m - n + 1)^{\gamma+\frac{1}{2}} \text{ and} \\ & (m + 1)^\alpha (n + 1)^{\beta+\delta+\frac{1}{2}+\epsilon} (m - n + 1)^\gamma \end{aligned} \right\} \quad \text{if } \gamma < \varkappa = -\frac{1}{2}, 0 \leq \delta,$$

$$\left. \begin{aligned} & (m + 1)^\alpha (n + 1)^{\beta+\delta} (m - n + 1)^{\gamma+\frac{1}{2}} \text{ and} \\ & (m + 1)^\alpha (n + 1)^{\beta+\delta+\frac{1}{2}} (m - n + 1)^\gamma \end{aligned} \right\} \quad \text{if } \gamma, \varkappa < -\frac{1}{2}, 0 \leq \delta.$$

By (4.5.54), applying Lemma 4.2.14 to the above list, we get the fifth list of conditions that guarantee (4.5.9) when  $m \geq n$ :

$$\gamma, \varkappa \leq -\frac{1}{2}, 0 \leq \delta \Rightarrow \begin{cases} \alpha + \gamma + \frac{1}{2}, \alpha + \beta + \delta < 0, \text{ or} \\ \alpha + \gamma, \alpha + \beta + \delta + \frac{1}{2} < 0. \end{cases} \quad (4.5.55)$$

**Sixth list of conditions**

We have

$$(m - p + 1)^\gamma \leq \begin{cases} (m + 1)^\gamma & \text{if } \gamma \geq 0 \\ (m - n + 1)^\gamma & \text{if } \gamma \leq 0 \end{cases} \quad (4.5.56)$$

for  $p = 0, \dots, n$ . Moreover, by (4.5.10), for all  $\epsilon > 0$ ,

$$\sum_{p=0}^n (n - p + 1)^{2\delta} = \sum_{q=1}^{n+1} q^{2\delta} \preccurlyeq \begin{cases} (n + 1)^{2\delta+1} & \text{if } \delta > -\frac{1}{2} \\ (n + 1)^\epsilon & \text{if } \delta = -\frac{1}{2} \\ 1 & \text{if } \delta < -\frac{1}{2}. \end{cases} \quad (4.5.57)$$

Applying the Cauchy-Schwartz inequality, we get

$$\sum_{p=0}^n (n - p + 1)^\delta (p + 1)^\varkappa \leq \left( \sum_{p=0}^n (n - p + 1)^{2\delta} \right)^{\frac{1}{2}} \left( \sum_{p=0}^n (p + 1)^{2\varkappa} \right)^{\frac{1}{2}}.$$

Therefore, by (4.5.56), (4.5.57) and (4.5.53), for all  $\epsilon > 0$ ,

$$(m + 1)^\alpha (n + 1)^\beta \sum_{p=0}^n (m - p + 1)^\gamma (n - p + 1)^\delta (p + 1)^\varkappa \preccurlyeq A_6, \quad (4.5.58)$$

where  $A_6 = A_6(m, n, \alpha, \beta, \gamma, \delta, \varkappa, \epsilon)$  can be taken to be equal to:

$$(m + 1)^{\alpha+\gamma} (n + 1)^{\beta+\epsilon} \quad \text{if } \begin{cases} \varkappa \leq \delta = -\frac{1}{2}, 0 \leq \gamma, \text{ or} \\ \delta \leq \varkappa = -\frac{1}{2}, 0 \leq \gamma, \end{cases}$$

$$(m + 1)^{\alpha+\gamma} (n + 1)^\beta \quad \text{if } \delta, \varkappa < -\frac{1}{2}, 0 \leq \gamma.$$

By (4.5.58), applying Lemma 4.2.14 to the above list, we get the sixth list of conditions that guarantee (4.5.9) when  $m \geq n$ :

$$\delta, \varkappa \leq -\frac{1}{2}, 0 \leq \gamma \Rightarrow \alpha + \gamma, \alpha + \beta + \gamma < 0. \quad (4.5.59)$$

**Seventh list of conditions**

By (4.5.10), (4.5.38) and (4.5.39), for all  $\epsilon > 0$ ,

$$\sum_{p=0}^n (n-p+1)^{3\delta} = \sum_{q=1}^{n+1} q^{3\delta} \asymp \begin{cases} (n+1)^{3\delta+1} & \text{if } \delta > -\frac{1}{3} \\ (n+1)^\epsilon & \text{if } \delta = -\frac{1}{3} \\ 1 & \text{if } \delta < -\frac{1}{3}, \end{cases} \quad (4.5.60)$$

$$\sum_{p=0}^n (p+1)^{3\kappa} \asymp \begin{cases} (n+1)^{3\kappa+1} & \text{if } \kappa > -\frac{1}{3} \\ (n+1)^\epsilon & \text{if } \kappa = -\frac{1}{3} \\ 1 & \text{if } \kappa < -\frac{1}{3}, \end{cases} \quad (4.5.61)$$

$$\sum_{p=0}^n (m-p+1)^{3\gamma} \asymp \begin{cases} (m+1)^{3\gamma+1} & \text{if } \gamma > -\frac{1}{3} \\ (m+1)^\epsilon & \text{if } \gamma = -\frac{1}{3} \\ (m-n+1)^{3\gamma+1} & \text{if } \gamma < -\frac{1}{3}, \end{cases} \quad (4.5.62)$$

$$\sum_{p=0}^n (m-p+1)^{3\gamma} \leq \begin{cases} (m+1)^{3\gamma}(n+1) & \text{if } \gamma \geq 0 \\ (m-n+1)^{3\gamma}(n+1) & \text{if } \gamma < 0. \end{cases} \quad (4.5.63)$$

Note that (4.5.63) is better than (4.5.62) for  $\gamma \geq 0$ , and it is an alternative estimate for  $\gamma < 0$ . Applying the generalized Hölder inequality [21], we get

$$\begin{aligned} & \sum_{p=0}^n (m-p+1)^\gamma (n-p+1)^\delta (p+1)^\kappa \\ & \leq \left( \sum_{p=0}^n (m-p+1)^{3\gamma} \right)^{\frac{1}{3}} \left( \sum_{p=0}^n (n-p+1)^{3\delta} \right)^{\frac{1}{3}} \left( \sum_{p=0}^n (p+1)^{3\kappa} \right)^{\frac{1}{3}}. \end{aligned}$$

Therefore, by (4.5.60)–(4.5.63),

$$(m+1)^\alpha (n+1)^\beta \sum_{p=0}^n (m-p+1)^\gamma (n-p+1)^\delta (p+1)^\kappa \asymp A_7, \quad (4.5.64)$$

where  $A_7 = A_7(m, n, \alpha, \beta, \gamma, \delta, \kappa)$  can be taken to be equal to:

$$\left. \begin{aligned} & (m+1)^\alpha (n+1)^{\beta+\delta+\kappa+\frac{2}{3}} (m-n+1)^{\gamma+\frac{1}{3}} \text{ and } \\ & (m+1)^\alpha (n+1)^{\beta+\delta+\kappa+1} (m-n+1)^\gamma \end{aligned} \right\} \text{if } \gamma < -\frac{1}{3} < \delta, \kappa,$$

$$\left. \begin{aligned} & (m+1)^\alpha (n+1)^{\beta+\delta+\frac{1}{3}} (m-n+1)^{\gamma+\frac{1}{3}} \text{ and } \\ & (m+1)^\alpha (n+1)^{\beta+\delta+\frac{2}{3}} (m-n+1)^\gamma \end{aligned} \right\} \text{if } \gamma, \kappa < -\frac{1}{3} < \delta.$$

By (4.5.64), applying Lemma 4.2.14 to the above list, we get the seventh list of conditions that guarantee (4.5.9) when  $m \geq n$ :

$$\gamma < -\frac{1}{3} < \delta, \varkappa \Rightarrow \begin{cases} \alpha + \gamma + \frac{1}{3}, \alpha + \beta + \delta + \varkappa + \frac{2}{3} < 0, \text{ or} \\ \alpha + \gamma, \alpha + \beta + \delta + \varkappa + 1 < 0, \end{cases} \quad (4.5.65)$$

$$\gamma, \varkappa < -\frac{1}{3} < \delta \Rightarrow \begin{cases} \alpha + \gamma + \frac{1}{3}, \alpha + \beta + \delta + \frac{1}{3} < 0, \text{ or} \\ \alpha + \gamma, \alpha + \beta + \delta + \frac{2}{3} < 0. \end{cases} \quad (4.5.66)$$

### Obtaining the sets $\mathfrak{S}_{ijk}$ from the lists of conditions

The left hand side of the conditions from the lists of Sections 4.5.2–4.5.2 involve only  $(\gamma, \delta, \varkappa)$ . Now, we indicate which of them define sets covering every  $Q_{ijk}$ , for the chosen subindices  $ijk$  equal to 515, 522, 252, 155, 212. Those conditions will produce the definition of  $\mathfrak{S}_{ijk} \subset \mathbb{R}^2 \times Q_{ijk}$  so that (4.5.9) holds for  $m \geq n$ .

The set  $Q_{515}$  is given by the left hand side of (4.5.25), whose right hand side is (4.5.1), defining  $\mathfrak{S}_{515}$ .

Any  $(\gamma, \delta, \varkappa) \in Q_{522}$  satisfies the left hand side of (4.5.59), whose right hand side is (4.5.2), defining  $\mathfrak{S}_{522}$ .

Any  $(\gamma, \delta, \varkappa) \in Q_{252}$  satisfies the left hand side of (4.5.13) or (4.5.14), and satisfies the left hand side of (4.5.55) and (4.5.66). So, when  $m \geq n$ , the estimate (4.5.9) is guaranteed for any  $(\alpha, \beta, \gamma, \delta, \varkappa) \in \mathbb{R}^2 \times Q_{252}$  satisfying both (4.5.13) and (4.5.14), or any of (4.5.55) or (4.5.66). On  $\mathbb{R}^2 \times Q_{252}$ , these conditions mean that  $(\alpha, \beta, \gamma, \delta, \varkappa)$  satisfies (4.5.3) and (4.5.4), defining  $\mathfrak{S}_{252}$ .

Any  $(\gamma, \delta, \varkappa) \in Q_{155}$  satisfies the left hand side of (4.5.13) or (4.5.14), and satisfies the left hand side of (4.5.51), (4.5.42) and (4.5.65). So, when  $m \geq n$ , the estimate (4.5.9) is guaranteed for any  $(\alpha, \beta, \gamma, \delta, \varkappa) \in \mathbb{R}^2 \times Q_{155}$  satisfying both (4.5.13) and (4.5.14), or any of (4.5.51), (4.5.42) or (4.5.65). On  $\mathbb{R}^2 \times Q_{155}$ , these conditions mean that  $(\alpha, \beta, \gamma, \delta, \varkappa)$  satisfies (4.5.3) and (4.5.5), defining  $\mathfrak{S}_{155}$ .

Any  $(\gamma, \delta, \varkappa) \in Q_{212}$  satisfies the left hand side of (4.5.26) or (4.5.27). So, when  $m \geq n$ , the estimate (4.5.9) is guaranteed for any  $(\alpha, \beta, \gamma, \delta, \varkappa) \in \mathbb{R}^2 \times Q_{212}$  satisfying both (4.5.26) and (4.5.27). On  $\mathbb{R}^2 \times Q_{212}$ , these conditions become (4.5.6) and (4.5.7), defining  $\mathfrak{S}_{212}$ .

### The preliminary estimate is satisfied on a convex set

Let us show the convexity of the set of elements  $x = (\alpha, \beta, \gamma, \delta, \varkappa) \in \mathbb{R}^5$  satisfying (4.5.9) for  $m \geq n$ , with  $\omega = \omega(x) > 0$ . For  $i = 0, 1$ , suppose that  $x_i = (\alpha_i, \beta_i, \gamma_i, \delta_i, \varkappa_i)$  satisfies (4.5.9) for  $m \geq n$  with  $\omega_i = \omega(x_i) > 0$ . Recall that the case where  $m \leq n$  follows from the case where  $m \geq n$  by using the mapping (4.5.8).

For  $0 < t < 1$ , let

$$x_t = (\alpha_t, \beta_t, \gamma_t, \delta_t, \varkappa_t) = (1-t)x_0 + tx_1, \quad \omega_t = (1-t)\omega_0 + t\omega_1 > 0.$$

By Hölder inequality, for all  $m \geq n$ ,

$$\begin{aligned} & \sum_{p=0}^n (m-p+1)^{\gamma_t} (n-p+1)^{\delta_t} (p+1)^{\varkappa_t} \\ &= \sum_{p=0}^n ((m-p+1)^{\gamma_0} (n-p+1)^{\delta_0} (p+1)^{\varkappa_0})^{1-t} \\ & \quad \times \sum_{p=0}^n ((m-p+1)^{\gamma_1} (n-p+1)^{\delta_1} (p+1)^{\varkappa_1})^t \\ & \leq \left( \sum_{p=0}^n (m-p+1)^{\gamma_0} (n-p+1)^{\delta_0} (p+1)^{\varkappa_0} \right)^{1-t} \\ & \quad \times \left( \sum_{p=0}^n (m-p+1)^{\gamma_1} (n-p+1)^{\delta_1} (p+1)^{\varkappa_1} \right)^t. \end{aligned}$$

So

$$\begin{aligned} (m+1)^{\alpha_t} (n+1)^{\beta_t} \sum_{p=0}^n (m-p+1)^{\gamma_t} (n-p+1)^{\delta_t} (p+1)^{\varkappa_t} \\ \leq ((m+1)^{-\omega_0} (n+1)^{-\omega_0})^{1-t} ((m+1)^{-\omega_1} (n+1)^{-\omega_1})^t \\ = (m+1)^{-\omega_t} (n+1)^{-\omega_t}. \end{aligned}$$

Thus  $x_t$  satisfies (4.5.9) for  $m \geq n$  with  $\omega_t$ . This completes the proof of Lemma 4.5.1.

## 4.6 The main estimates

Here, we show the estimates used in the proofs of Propositions 4.4.6 and 4.4.10. We continue with the notation of Section 4.5. Moreover let  $(\sigma, \tau, \theta)$  denote the standard coordinates of  $\mathbb{R}^3$ . Consider the affine injection  $\mathbb{R}^3 \rightarrow \mathbb{R}^5$  and the affine isomorphism of  $\mathbb{R}^3$  defined by

$$(\sigma, \tau, \theta) \mapsto \left( \frac{1}{4} - \frac{\sigma}{2}, -\frac{1}{4} - \frac{\tau}{2}, \sigma - \theta - 1, \tau - \theta, \theta - \frac{1}{2} \right), \quad (4.6.1)$$

$$(\sigma, \tau, \theta) \mapsto (\tau + 1, \sigma - 1, \theta). \quad (4.6.2)$$

The mapping (4.6.2) is the reflection with respect to the plane defined by  $\sigma = \tau + 1$ , and it corresponds to the mapping (4.5.8) via (4.6.1). Let  $\check{\mathfrak{K}}, \check{\mathfrak{K}}' \subset \mathbb{R}^3$  be the inverse images of  $\check{\mathfrak{S}}, \check{\mathfrak{S}}'$  by (4.6.1), and let  $\check{\mathfrak{K}}_{\text{conv}}, \check{\mathfrak{K}}'_{\text{conv}}$  be their convex hulls. So  $\check{\mathfrak{K}}_{\text{conv}}, \check{\mathfrak{K}}'_{\text{conv}}$  are contained in the inverse images of  $\check{\mathfrak{S}}_{\text{conv}}, \check{\mathfrak{S}}'_{\text{conv}}$  by (4.6.1), and  $\check{\mathfrak{K}}', \check{\mathfrak{K}}'_{\text{conv}}$  are the images of  $\check{\mathfrak{K}}, \check{\mathfrak{K}}_{\text{conv}}$  by (4.6.2). Thus  $\check{\mathfrak{K}}_{\text{conv}} \cap \check{\mathfrak{K}}'_{\text{conv}}$  is symmetric with respect to the plane  $\sigma = \tau + 1$ . We will show the following.

**Lemma 4.6.1.**  $\check{\mathfrak{K}}_{\text{conv}} \cap \check{\mathfrak{K}}'_{\text{conv}}$  consists of the elements  $(\sigma, \tau, \theta) \in \mathbb{R}^3$  that satisfy (1.10.8).

The following is a direct consequence of Lemmas 4.5.1 and 4.6.1.

**Corollary 4.6.2.** If  $(\sigma, \tau, \theta) \in \mathbb{R}^3$  satisfies (1.10.8), then there is some  $\omega > 0$  such that (4.5.9) holds with the image  $(\alpha, \beta, \gamma, \delta, \varkappa)$  of  $(\sigma, \tau, \theta)$  by (4.6.1).

Let  $\check{\mathfrak{J}} \subset \mathbb{R}^2$  be the inverse image of  $\check{\mathfrak{K}}_{\text{conv}} \cap \check{\mathfrak{K}}'_{\text{conv}}$  by the affine injection  $\mathbb{R}^2 \rightarrow \mathbb{R}^3$ ,  $(\sigma, \tau) \mapsto (\sigma, \tau, \tau)$ . The following is a direct consequence of Lemma 4.6.1.

**Lemma 4.6.3.**  $\check{\mathfrak{J}}$  consists of the elements  $(\sigma, \tau) \in \mathbb{R}^2$  that satisfy (1.10.6).

Lemma 4.6.3 and Corollary 4.6.2 have the following direct consequence.

**Corollary 4.6.4.** If  $(\sigma, \tau) \in \mathbb{R}^2$  satisfies (1.10.6), then there is some  $\omega > 0$  such that (4.5.9) holds with the image  $(\alpha, \beta, \gamma, \delta, \varkappa)$  of  $(\sigma, \tau, \tau)$  by (4.6.1).

Let us prove Lemma 4.6.1. For the subindices  $ijk$  equal to 515, 522, 252, 155 and 212, let  $\check{\mathfrak{K}}_{ijk}$  and  $R_{ijk}$  be the inverse images of  $\check{\mathfrak{S}}_{ijk}$  and  $\mathbb{R}^2 \times Q_{ijk}$  by the mapping (4.6.1). Thus  $\check{\mathfrak{K}} = \check{\mathfrak{K}}_{515} \cup \check{\mathfrak{K}}_{522} \cup \check{\mathfrak{K}}_{252} \cup \check{\mathfrak{K}}_{155} \cup \check{\mathfrak{K}}_{212}$ . Moreover, for every  $\theta \in \mathbb{R}$ , let

$$\begin{aligned} I_1^1(\theta) &= (-\infty, \theta], & I_1^2(\theta) &= (-\infty, \theta - 1], & I_1^3 &= (-\infty, -\frac{1}{2}], \\ I_2^1(\theta) &= (\theta, \theta + \frac{1}{2}], & I_2^2(\theta) &= (\theta - 1, \theta - \frac{1}{2}], & I_2^3 &= (-\frac{1}{2}, 0], \\ I_3^1(\theta) &= (\theta + \frac{1}{2}, \theta + \frac{2}{3}], & I_3^2(\theta) &= (\theta - \frac{1}{2}, \theta - \frac{1}{3}], & I_3^3 &= (0, \frac{1}{6}], \\ I_4^1(\theta) &= (\theta + \frac{2}{3}, \theta + 1), & I_4^2(\theta) &= (\theta - \frac{1}{3}, \theta), & I_4^3 &= (\frac{1}{6}, \frac{1}{2}], \\ I_5^1(\theta) &= [\theta + 1, \infty), & I_5^2(\theta) &= [\theta, \infty), & I_5^3 &= [\frac{1}{2}, \infty). \end{aligned}$$

It can be directly checked that

$$R_{ijk} = \{ (\sigma, \tau, \theta) \in \mathbb{R}^3 \mid (\sigma, \tau) \in I_i^1(\theta) \times I_j^2(\theta), \theta \in I_k^3 \}.$$

Simple computations show that, via (4.6.1), the conditions defining the sets  $\check{\mathfrak{S}}_{ijk}$  (Section 4.5.1) become the following descriptions of the sets  $\check{\mathfrak{K}}_{ijk}$  (Figure 4.6.1-(a)):

$\mathfrak{R}_{515}$ : This is the subset of  $R_{515}$  defined by

$$\frac{\sigma}{2} - \frac{3}{4} < \theta, \quad \sigma - \tau - 3 < 0.$$

$\mathfrak{R}_{522}$ : This is the subset of  $R_{522}$  defined by

$$\frac{\sigma}{2} - \frac{3}{4}, \frac{\sigma - \tau}{2} - 1 < \theta.$$

$\mathfrak{R}_{252}$ : This is the subset of  $R_{252}$  defined by

$$\begin{aligned} & \frac{\sigma + \tau - 1}{2} < \theta, \\ & \left\{ \begin{array}{l} \frac{\sigma}{2} - \frac{1}{4}, \frac{\tau - \sigma}{2} < \theta, \text{ or} \\ \frac{\sigma}{2} - \frac{5}{12}, \frac{\tau - \sigma}{2} + \frac{1}{3} < \theta, \text{ or} \\ \frac{\sigma}{2} - \frac{3}{4} < \theta, \tau - \sigma + 1 < 0. \end{array} \right. \end{aligned} \quad (4.6.3)$$

$\mathfrak{R}_{155}$ : This is the subset of  $R_{155}$  defined by (4.6.3) and

$$\left\{ \begin{array}{l} \frac{\sigma}{2} + \frac{1}{4} < \theta, \tau - \sigma - 1 < 0, \text{ or} \\ \frac{\sigma}{2} - \frac{1}{4} < \theta, \tau - \sigma < 0, \text{ or} \\ \frac{\sigma}{2} - \frac{5}{12} < \theta, \tau - \sigma + \frac{1}{3} < 0, \text{ or} \\ \frac{\sigma}{2} - \frac{3}{4} < \theta, \tau - \sigma + 1 < 0. \end{array} \right.$$

$\mathfrak{R}_{212}$ : This is the subset of  $R_{212}$  defined by

$$\begin{aligned} & \frac{\sigma}{2} - \frac{1}{4} \leq \theta \Rightarrow \theta < \frac{\sigma + \tau + 1}{2}, \\ & \theta \leq \frac{\sigma}{2} - \frac{1}{4} \Rightarrow \frac{\sigma}{2} - \frac{3}{4}, \frac{\sigma - \tau}{2} - 1 < \theta. \end{aligned}$$

With tedious computations assisted by graphics produced with Mathematica, it follows that  $\check{\mathfrak{R}}_{\text{conv}}$  is the open subset of  $\mathbb{R}^3$  defined by (Figure 4.6.1-(b))

$$\left. \begin{aligned} & \frac{\sigma - \tau}{2} - 1, \frac{\tau - \sigma}{2}, \frac{\sigma + \tau - 1}{4}, \frac{\sigma + 3\tau - 2}{14}, \frac{\sigma + \tau - 1}{2} < \theta < \frac{\sigma + \tau + 1}{2}, \\ & \tau - 1 < \sigma < \tau + 3. \end{aligned} \right\} \quad (4.6.4)$$

This is a “semi-infinite bar” with 4 lateral faces, and 4 faces at the “bounded end”.

Applying the affine transformation (4.6.2) to this description, we get that  $\check{\mathfrak{R}}'_{\text{conv}}$  consists of the triples  $(\sigma, \tau, \theta) \in \mathbb{R}^3$  satisfying the following conditions:

$$\left. \begin{aligned} & \frac{\sigma - \tau}{2} - 1, \frac{\tau - \sigma}{2}, \frac{\sigma + \tau - 1}{4}, \frac{3\sigma + \tau - 4}{14}, \frac{\sigma + \tau - 1}{2} < \theta < \frac{\sigma + \tau + 1}{2}, \\ & \tau - 1 < \sigma < \tau + 3. \end{aligned} \right\} \quad (4.6.5)$$

Combining (4.6.4) and (4.6.5), it follows that  $\check{\mathfrak{R}}_{\text{conv}} \cap \check{\mathfrak{R}}'_{\text{conv}}$  is given by (1.10.8) (Figure 1.10.2), completing the proof of Lemma 4.6.1.

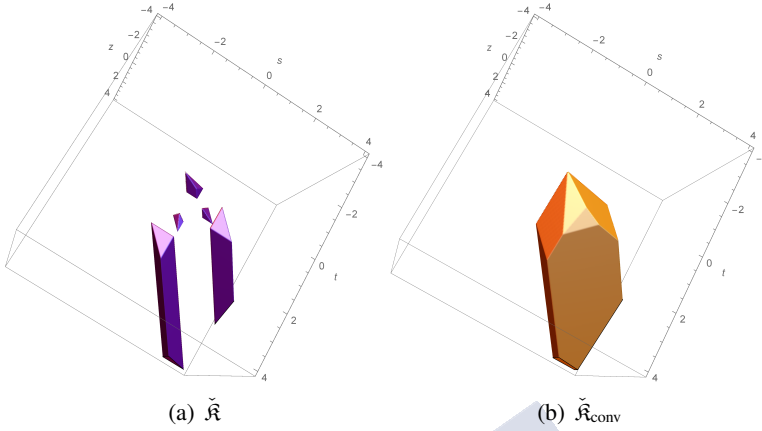

Figure 4.6.1: The sets  $\check{\mathfrak{K}}$  and  $\check{\mathfrak{K}}_{\text{conv}}$ .

*Remark 4.6.5.* In Sections 4.5.2–4.5.2, we have only written the cases that provide the most general conditions to define  $\mathfrak{S}_{515}$ ,  $\mathfrak{S}_{522}$ ,  $\mathfrak{S}_{252}$ ,  $\mathfrak{S}_{155}$ ,  $\mathfrak{S}_{212}$ . But indeed much more hidden work was needed to produce this shorter proof:

1. We have computed all cases in Sections 4.5.2–4.5.2, giving rise to seven long lists of conditions that guarantee (4.5.9) when  $m \geq n$ .
2. We have studied which of those conditions are the most general ones on every subset  $\mathbb{R}^2 \times Q_{ijk}$ , for all  $ijk = 1, \dots, 5$ . This produces 125 sets  $\mathfrak{S}_{ijk}$ , whose inverse images by (4.6.1) give 125 sets  $\mathfrak{K}_{ijk}$ . The corresponding unions are denoted by  $\mathfrak{S}$  and  $\mathfrak{K}$ , and their convex hulls by  $\mathfrak{S}_{\text{conv}}$  and  $\mathfrak{K}_{\text{conv}}$ .
3. We got that 41 sets  $\mathfrak{K}_{ijk}$  are empty, including the 25 sets of the form  $\mathfrak{K}_{ij1}$ , and the remaining 84 sets  $\mathfrak{K}_{ijk}$  fit together forming a “semi-infinite bar” (Figures 4.6.2 and 4.6.3).
4. With tedious computations, we have shown that  $\mathfrak{K}_{\text{conv}}$  is given by (4.6.4).
5. We have chosen the most simple family,  $\mathfrak{K}_{515}$ ,  $\mathfrak{K}_{522}$ ,  $\mathfrak{K}_{252}$ ,  $\mathfrak{K}_{155}$ ,  $\mathfrak{K}_{212}$ , defining the same convex hull ( $\check{\mathfrak{K}}_{\text{conv}} = \mathfrak{K}_{\text{conv}}$ ).
6. Finally, we have made some attempts to improve the estimates of Section 4.5.2 by using more general versions of the Hölder inequality [21]. Some better estimates were obtained in this way, but they produce the same set  $\mathfrak{K}_{\text{conv}}$  after taking the convex hull.

*Remark 4.6.6.* The set  $\mathfrak{S}_{\text{conv}}$  may have a simple expression, like  $\mathfrak{K}_{\text{conv}}$ , but its computation became too involved. This is the reason we have used  $\mathfrak{K}_{\text{conv}}$ , obtaining the conditions of Theorem 1.10.3, which are general enough for the applications contained in Chapter 2. But, of course, the inverse image of  $\mathfrak{S}_{\text{conv}}$  by (4.6.1) is possibly larger than  $\mathfrak{K}_{\text{conv}}$ . Therefore a simple expression of  $\mathfrak{S}_{\text{conv}}$  would possibly give a better version of Theorem 1.10.3. Even a simple expression of  $\tilde{\mathfrak{S}}_{\text{conv}}$  would possibly give a better version of Theorem 1.10.3.

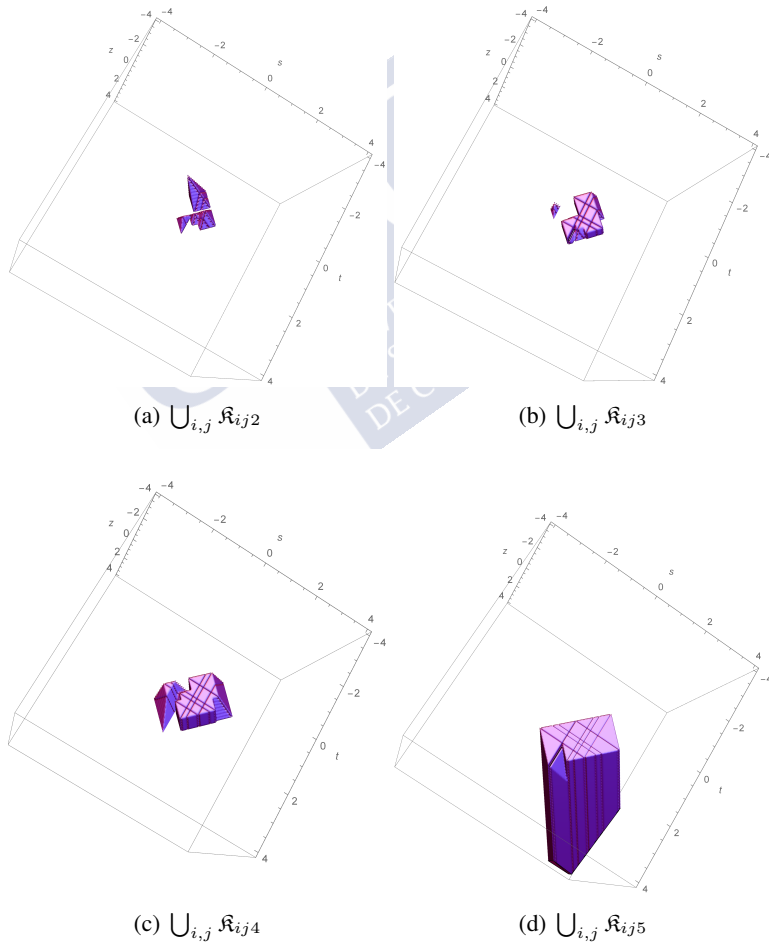

Figure 4.6.2: Construction of  $\mathfrak{R}$ .

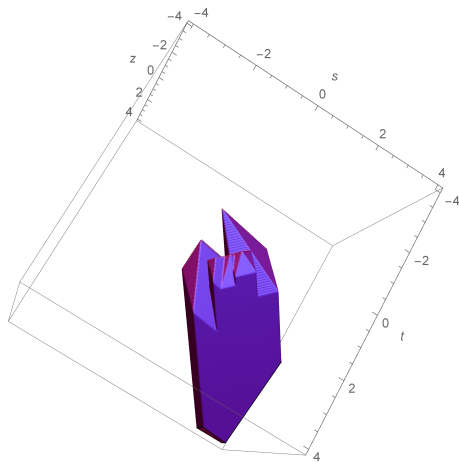

Figure 4.6.3:  $\mathfrak{K}$

### 4.7 Operators induced on $\mathbb{R}_+$

This section is devoted to the study of self-adjoint operators on  $\mathbb{R}_+$  induced by the Dunkl harmonic oscillator on  $\mathbb{R}$  [4], and also by the perturbation of the Dunkl harmonic oscillator on  $\mathbb{R}$  considered along this chapter.

Let  $\rho$  denote the canonical coordinate of  $\mathbb{R}_+$ . Consider the spaces of real/complex-valued functions,  $C^\infty = C^\infty(\mathbb{R})$ ,  $C_+^\infty = C^\infty(\mathbb{R}_+)$  and  $C_{+,0}^\infty = C_0^\infty(\mathbb{R}_+)$ , where the subindex 0 is used for compactly supported functions or sections. For every  $a \in \mathbb{R}$ , the operator of multiplication by the function  $\rho^a$  on  $C_+^\infty$  will be also denoted by  $\rho^a$ . We have

$$[\frac{d}{d\rho}, \rho^a] = a\rho^{a-1}, \quad [\frac{d^2}{d\rho^2}, \rho^a] = 2a\rho^{a-1} \frac{d}{d\rho} + a(a-1)\rho^{a-2}. \tag{4.7.1}$$

For every  $\phi \in C^\infty$ , let  $\phi_+ = \phi|_{\mathbb{R}_+}$ , and let  $\mathcal{S}_{\text{ev/odd},+} = \{\phi_+ \mid \phi \in \mathcal{S}_{\text{ev/odd}}\}$ . For  $c, d > -\frac{1}{2}$ , let  $L_{c,+}^2 = L^2(\mathbb{R}_+, \rho^{2c} d\rho)$  and  $L_{c,d,+}^2 = L_{c,+}^2 \oplus L_{d,+}^2$ , whose scalar products are denoted by  $\langle \cdot, \cdot \rangle_c$  and  $\langle \cdot, \cdot \rangle_{c,d}$ , and the corresponding norms by  $\| \cdot \|_c$  and  $\| \cdot \|_{c,d}$ , respectively. The simpler notation  $L_+^2$ ,  $\langle \cdot, \cdot \rangle$  and  $\| \cdot \|$  is used when  $c = 0$ . Recall that the harmonic oscillator on  $C_+^\infty$  is the operator  $H = -\frac{d^2}{d\rho^2} + s^2\rho^2$  ( $s > 0$ ). For  $c_1, c_2, d_1, d_2 \in \mathbb{R}$ , let

$$P_0 = H - 2c_1\rho^{-1} \frac{d}{d\rho} + c_2\rho^{-2}, \quad Q_0 = H - 2d_1 \frac{d}{d\rho} \rho^{-1} + d_2\rho^{-2}. \tag{4.7.2}$$

**Proposition 4.7.1.** [4, Theorem 1.4] *If  $a \in \mathbb{R}$  satisfies*

$$a^2 + (2c_1 - 1)a - c_2 = 0, \tag{4.7.3}$$

$$\sigma := a + c_1 > -\frac{1}{2}, \tag{4.7.4}$$

then the following holds:

- (i)  $P_0$ , with  $D(P_0) = \rho^a \mathcal{S}_{\text{ev},+}$ , is essentially self-adjoint in  $L^2_{c_1,+}$ .
- (ii) The spectrum of  $\mathcal{P}_0 := \overline{P_0}$  consists of the eigenvalues

$$\lambda_k = (2k + 1 + 2\sigma)s, \quad (4.7.5)$$

for  $k \in 2\mathbb{N}$ , with multiplicity one and corresponding normalized eigenfunctions

$$\chi_k = \chi_{s,\sigma,a,k} := \sqrt{2} \rho^a \phi_{s,\sigma,k,+}.$$

- (iii)  $D^\infty(\mathcal{P}_0) = \rho^a \mathcal{S}_{\text{ev},+}$ .

**Proposition 4.7.2** (See [4, Section 5]). *If  $b \in \mathbb{R}$  satisfies*

$$b^2 + (2d_1 + 1)b - d_2 = 0, \quad (4.7.6)$$

$$\tau := b + d_1 > -\frac{3}{2}, \quad (4.7.7)$$

then the following holds:

- (i)  $Q_0$ , with  $D(Q_0) = \rho^b \mathcal{S}_{\text{odd},+}$ , is essentially self-adjoint in  $L^2_{d_1,+}$ .
- (ii) The spectrum of  $\mathcal{Q}_0 := \overline{Q_0}$  consists of the eigenvalues given by the expression (4.7.5), for  $k \in 2\mathbb{N} + 1$  and using  $\tau$  instead of  $\sigma$ , with multiplicity one and corresponding normalized eigenfunctions  $\chi_k = \chi_{s,\tau,b,k} := \sqrt{2} \rho^b \phi_{s,\tau,k,+}$ .
- (iii)  $D^\infty(Q_0) = \rho^b \mathcal{S}_{\text{odd},+}$ .

**Corollary 4.7.3.** *Let  $\xi > 0$  and*

$$0 < u < 1. \quad (4.7.8)$$

*If  $a \in \mathbb{R}$  satisfies (4.7.3) and*

$$\sigma := a + c_1 > u - \frac{1}{2}, \quad (4.7.9)$$

then there is a positive self-adjoint operator  $\mathcal{P}$  in  $L^2_{c_1,+}$  satisfying the following:

- (i)  $\rho^a \mathcal{S}_{\text{ev},+}$  is a core of  $\mathcal{P}^{1/2}$  and, for all  $\phi, \psi \in \rho^a \mathcal{S}_{\text{ev},+}$ ,

$$\langle \mathcal{P}^{1/2} \phi, \mathcal{P}^{1/2} \psi \rangle_{c_1} = \langle P_0 \phi, \psi \rangle_{c_1} + \xi \langle \rho^{-u} \phi, \rho^{-u} \psi \rangle_{c_1}. \quad (4.7.10)$$

- (ii)  $\mathcal{P}$  has a discrete spectrum. Let  $\lambda_0 \leq \lambda_2 \leq \dots$  be its eigenvalues, repeated according to their multiplicity. There is some  $D = D(\sigma, u) > 0$  and, for any  $\epsilon > 0$ , there is some  $C = C(\epsilon, \sigma, u) > 0$  so that (1.10.2) and (1.10.3) hold for all  $k \in 2\mathbb{N}$ .

**Corollary 4.7.4.** For  $\xi$  and  $u$  like in Corollary 4.7.3, if  $b \in \mathbb{R}$  satisfies (4.7.6) and

$$\tau := b + d_1 > u - \frac{3}{2}, \quad (4.7.11)$$

then there is a positive self-adjoint operator  $\mathcal{Q}$  in  $L^2_{d_1,+}$  satisfying the following:

(i)  $\rho^b \mathcal{S}_{\text{odd},+}$  is a core of  $\mathcal{Q}^{1/2}$  and, for all  $\phi, \psi \in \rho^b \mathcal{S}_{\text{odd},+}$ ,

$$\langle \mathcal{Q}^{1/2} \phi, \mathcal{Q}^{1/2} \psi \rangle_{d_1} = \langle Q_0 \phi, \psi \rangle_{d_1} + \xi \langle \rho^{-u} \phi, \rho^{-u} \psi \rangle_{d_1}. \quad (4.7.12)$$

(ii)  $\mathcal{Q}$  has a discrete spectrum. Let  $\lambda_1 \leq \lambda_3 \leq \dots$  be its eigenvalues, repeated according to their multiplicity. There is some  $D = D(\tau, u) > 0$  and, for any  $\epsilon > 0$ , there is some  $C = C(\epsilon, \tau, u) > 0$  so that (1.10.2) and (1.10.3) are satisfied, for  $k \in 2\mathbb{N} + 1$  and with  $\tau$  instead of  $\sigma$ .

**Corollary 4.7.5.** Consider the notation and conditions of Corollaries 4.7.3 and 4.7.4. Fix also some  $\eta \in \mathbb{R}$ , let

$$\theta > -\frac{1}{2} \quad (4.7.13)$$

and set  $v = \sigma + \tau - 2\theta$ . If moreover the hypothesis (a)–(d) of Theorem 1.10.3 are satisfied, then there is a positive self-adjoint operator  $\mathcal{W}$  in  $L^2_{c_1, d_1, +}$  satisfying the following:

(i)  $x^a \mathcal{S}_{\text{ev},+} \oplus x^b \mathcal{S}_{\text{odd},+}$  is a core of  $\mathcal{W}^{1/2}$ , and, for  $\phi = (\phi_1, \phi_2)$  and  $\psi = (\psi_1, \psi_2)$  in  $x^a \mathcal{S}_{\text{ev},+} \oplus x^b \mathcal{S}_{\text{odd},+}$ ,

$$\begin{aligned} \langle \mathcal{W}^{1/2} \phi, \mathcal{W}^{1/2} \psi \rangle_{c_1, d_1} &= \langle (P_0 \oplus Q_0) \phi, \psi \rangle_{c_1, d_1} + \xi \langle x^{-u} \phi, x^{-u} \psi \rangle_{c_1, d_1} \\ &\quad + \eta (\langle x^{-a-b-1} \phi_2, \psi_1 \rangle_\theta + \langle \phi_1, x^{-a-b-1} \psi_2 \rangle_\theta). \end{aligned} \quad (4.7.14)$$

(ii) Let  $\varsigma_k = \sigma$  if  $k$  is even, and  $\varsigma_k = \tau$  if  $k$  is odd.  $\mathcal{W}$  has a discrete spectrum. Its eigenvalues form two groups,  $\lambda_0 \leq \lambda_2 \leq \dots$  and  $\lambda_1 \leq \lambda_3 \leq \dots$ , repeated according to their multiplicity, such that there is some  $D = D(\sigma, \tau, u) > 0$  and, for every  $\epsilon > 0$ , there are  $C = C(\epsilon, \sigma, \tau, u) > 0$  and  $E = E(\epsilon, \sigma, \tau, \theta) > 0$  so that (1.10.10) and (1.10.11) hold for all  $k \in \mathbb{N}$ .

(iii) If  $\tilde{u} \in \mathbb{R}$  satisfies (1.10.12), then there is some  $D = D(\sigma, \tau, u) > 0$  and, for any  $\epsilon > 0$ , there is some  $\tilde{C} = \tilde{C}(\epsilon, \sigma, \tau, u) > 0$  so that (1.10.13) holds for all  $k \in \mathbb{N}$ .

(iv) If  $u = \frac{v+1}{2}$  and  $\xi \geq |\eta|$ , then there is some  $\tilde{D} = \tilde{D}(\sigma, \tau, u) > 0$  so that (1.10.14) holds for all  $k \in \mathbb{N}$ .

- (v) If we add the term  $\xi' \langle \phi_1, \psi_1 \rangle_{c_1} + \xi'' \langle \phi_2, \psi_2 \rangle_{d_1}$  to the right hand side of (4.7.14), for some  $\xi', \xi'' \in \mathbb{R}$ , then the result holds as well with the additional term  $\max\{\xi', \xi''\}$  in the right hand side of (1.10.11), and the additional term,  $\xi'$  for  $k \in 2\mathbb{N}$  and  $\xi''$  for  $k \in 2\mathbb{N} + 1$ , in the right hand sides of (1.10.10), (1.10.13) and (1.10.14).

Corollaries 4.7.3, 4.7.4 and 4.7.5 follow directly from Theorems 1.10.1 and 1.10.3 because the given conditions on  $a$  and  $b$  characterize the cases where  $P_0$  and  $Q_0$  correspond to  $|\rho|^a U_{\sigma, \text{ev}} |\rho|^{-a}$  and  $|\rho|^b U_{\tau, \text{odd}} |\rho|^{-b}$ , respectively, via the isomorphisms  $|\rho|^a \mathcal{S}_{\text{ev}} \rightarrow \rho^a \mathcal{S}_{\text{ev},+}$  and  $|\rho|^b \mathcal{S}_{\text{odd}} \rightarrow \rho^b \mathcal{S}_{\text{odd},+}$  defined by restriction [4, Theorem 1.4 and Section 5].

*Remark 4.7.6.* (i) If  $h$  is a bounded measurable function on  $\mathbb{R}_+$  with  $h(\rho) \rightarrow 1$  as  $\rho \rightarrow 0$ , then  $\langle h\chi_0, \chi_0 \rangle_{c_1} \rightarrow 1$  as  $s \rightarrow \infty$  [5, Lemma 7.3].

- (ii) The existence of  $a \in \mathbb{R}$  satisfying (4.7.3) is characterized by the condition  $(2c_1 - 1)^2 + 4c_2 \geq 0$ , which holds if  $c_2 \geq \min\{0, 2c_1\}$ . If  $c_2 = 0$ , then (4.7.3) means that  $a \in \{0, 1 - 2c_1\}$ . If  $c_2 = 2c_1$ , then (4.7.3) means that  $a \in \{1, -2c_1\}$ .
- (iii) The existence of  $b \in \mathbb{R}$  satisfying (4.7.6) is characterized by the condition  $(2d_1 + 1)^2 + 4d_2 \geq 0$ , which holds if  $d_2 \geq \min\{0, -2d_1\}$ . If  $d_2 = 0$ , then (4.7.6) means that  $b \in \{0, -1 - 2d_1\}$ . If  $d_2 = -2d_1$ , then (4.7.6) means that  $b \in \{-1, -2d_1\}$ .
- (iv) Propositions 4.7.1 and 4.7.2 are indeed equivalent, as well as Corollaries 4.7.3 and 4.7.4, because, if  $c_1 = d_1 + 1$  and  $c_2 = d_2$ , then  $Q_0 = \rho P_0 \rho^{-1}$  by (4.7.1), and  $\rho : L_{c_1,+}^2 \rightarrow L_{d_1,+}^2$  is a unitary isomorphism.

- (v) Remarks 1.10.2-(ii) and 1.10.4-(i) have obvious versions for these corollaries. In particular, we have  $\mathcal{P} = \overline{P}$ ,  $\mathcal{Q} = \overline{Q}$  and  $\mathcal{W} = \overline{W}$ , where

$$P = P_0 + \xi \rho^{-2u}, \quad Q = Q_0 + \xi \rho^{-2u}, \quad (4.7.15)$$

$$\begin{aligned} W &= \begin{pmatrix} P & \eta \rho^{2(\theta-\sigma)+a-b-1} \\ \eta \rho^{2(\theta-\tau)+b-a-1} & Q \end{pmatrix} \\ &= \begin{pmatrix} P & \eta \rho^{2(\theta-c_1)-a-b-1} \\ \eta \rho^{2(\theta-d_1)-a-b-1} & Q \end{pmatrix}, \end{aligned} \quad (4.7.16)$$

with  $D(P) = D^\infty(\mathcal{P})$ ,  $D(Q) = D^\infty(\mathcal{Q})$  and  $D(W) = D^\infty(\mathcal{W})$ .

- (vi) According to Remark 1.10.4-(ii), we can write (4.7.14) as

$$\begin{aligned} \langle \mathcal{W}^{1/2} \phi, \mathcal{W}^{1/2} \psi \rangle_{c_1, d_1} &= \langle (P_0 \oplus Q_0) \phi, \psi \rangle_{c_1, d_1} + \xi \langle \rho^{-u} \phi, \rho^{-u} \psi \rangle_{c_1, d_1} \\ &\quad + \eta \langle \langle \rho^{-a-b+1} \phi_2, \psi_1 \rangle_{\theta'} + \langle \phi_1, \rho^{-a-b+1} \psi_2 \rangle_{\theta'} \rangle, \end{aligned}$$

and we have

$$W = \begin{pmatrix} P & \eta\rho^{2(\theta'-c_1)-a-b+1} \\ \eta\rho^{2(\theta'-d_1)-a-b+1} & Q \end{pmatrix}.$$

(vii) According to Remark 4.2.21, it is satisfied that

$$\begin{aligned} D(\mathcal{P}^{1/2}) &= D(\mathcal{P}_0^{1/2}), & D(\mathcal{Q}^{1/2}) &= D(\mathcal{Q}_0^{1/2}), \\ D(\mathcal{W}^{1/2}) &= D((\mathcal{P}_0 \oplus \mathcal{Q}_0)^{1/2}). \end{aligned}$$

Thus the expressions (4.7.10), (4.7.12) and (4.7.14) can be extended to  $\phi$  and  $\psi$  in  $D(\mathcal{P}^{1/2})$ ,  $D(\mathcal{Q}^{1/2})$  and  $D(\mathcal{W}^{1/2})$ , respectively, using

$$\begin{aligned} &\langle \mathcal{P}_0^{1/2}\phi, \mathcal{P}_0^{1/2}\psi \rangle_{c_1}, & \langle \mathcal{Q}_0^{1/2}\phi, \mathcal{Q}_0^{1/2}\psi \rangle_{d_1}, \\ &\langle (\mathcal{P}_0 \oplus \mathcal{Q}_0)^{1/2}\phi, (\mathcal{P}_0 \oplus \mathcal{Q}_0)^{1/2}\psi \rangle_{c_1, d_1} \end{aligned}$$

instead of

$$\begin{aligned} &\langle P_0\phi, \psi \rangle_{c_1}, & \langle Q_0\phi, \psi \rangle_{d_1}, \\ &\langle (P_0 \oplus Q_0)\phi, \psi \rangle_{c_1, d_1}, \end{aligned}$$

respectively.

Consider the conditions and notation of Corollary 4.7.3, and the notation of Proposition 4.7.1. Take a complete orthonormal system  $\{\hat{\chi}_k = \hat{\chi}_{\mathcal{P},k} \mid k \in 2\mathbb{N}\}$  of  $L^2_{c_1,+}$  so that every  $\hat{\chi}_k$  is a  $\lambda_k$ -eigenfunction of  $\mathcal{P}$ . Let  $\hat{\chi}'_k = \hat{\chi}'_{\mathcal{P},k}$  and  $\hat{\chi}''_k = \hat{\chi}''_{\mathcal{P},k}$  denote the orthogonal projections of every  $\hat{\chi}_k$  to the subspaces spanned by  $\chi_k$  and  $\{\chi_i \mid k > i \in 2\mathbb{N}\}$ , respectively; in particular,  $\hat{\chi}''_0 = 0$ . Let also  $\hat{\chi}'''_k = \hat{\chi}'''_{\mathcal{P},k} = \hat{\chi}_k - \hat{\chi}'_k - \hat{\chi}''_k$ .

**Lemma 4.7.7.**  $\|\hat{\chi}'_{\mathcal{P},k}\|_{c_1} \rightarrow 1$  as  $s \rightarrow \infty$  for every  $k \in 2\mathbb{N}$ .

*Proof.* We proceed by induction on  $k$ . For  $k = 0$ , take some  $\epsilon > 0$  and  $C > 0$  satisfying (1.10.3). By Proposition 4.7.1-(ii), Corollary 4.7.3-(ii) and Remark 4.7.6-(vii), we get

$$\begin{aligned} &(1 + 2\sigma)(s + \xi\epsilon s^u) + \xi C s^u \geq \lambda_0 \\ &= \langle \mathcal{P}^{1/2}\hat{\chi}_0, \mathcal{P}^{1/2}\hat{\chi}_0 \rangle_{c_1} > \langle \mathcal{P}_0^{1/2}\hat{\chi}_0, \mathcal{P}_0^{1/2}\hat{\chi}_0 \rangle_{c_1} \\ &= \langle \mathcal{P}_0^{1/2}\hat{\chi}'_0, \mathcal{P}_0^{1/2}\hat{\chi}'_0 \rangle_{c_1} + \langle \mathcal{P}_0^{1/2}\hat{\chi}'''_0, \mathcal{P}_0^{1/2}\hat{\chi}'''_0 \rangle_{c_1} \\ &\geq (1 + 2\sigma)s \|\hat{\chi}'_0\|_{c_1}^2 + (5 + 2\sigma)s \|\hat{\chi}'''_0\|_{c_1}^2 \\ &= (1 + 2\sigma)s + 4s \|\hat{\chi}'''_0\|_{c_1}^2, \end{aligned}$$

giving

$$\|\hat{\chi}_0'''\|_{c_1}^2 < \frac{((1+2\sigma)\epsilon + C)\xi}{4s^{1-u}} \rightarrow 0$$

as  $s \rightarrow \infty$ , and therefore  $\|\hat{\chi}'_0\|_{c_1}^2 \rightarrow 1$ .

Now, take any even integer  $k > 0$  and suppose that the result holds for all even indices  $< k$ . This yields  $\|\hat{\chi}''_k\|_{c_1} \rightarrow 0$  as  $s \rightarrow \infty$ . Thus, given any  $\delta > 0$ , we have  $\|\hat{\chi}''_k\|_{c_1}^2 < \delta/k$  for  $s$  large enough. Take some  $\epsilon > 0$  and  $C > 0$  satisfying (1.10.3). By Proposition 4.7.1-(ii), Corollary 4.7.3-(ii) and Remark 4.7.6-(vii), we get

$$\begin{aligned} (2k+1+2\sigma)(s+\xi\epsilon s^u) + \xi C s^u &\geq \lambda_k \\ &= \langle \mathcal{P}^{1/2}\hat{\chi}_k, \mathcal{P}^{1/2}\hat{\chi}_k \rangle_{c_1} > \langle \mathcal{P}_0^{1/2}\hat{\chi}_k, \mathcal{P}_0^{1/2}\hat{\chi}_k \rangle_{c_1} \\ &= \langle \mathcal{P}_0^{1/2}\hat{\chi}'_k, \mathcal{P}_0^{1/2}\hat{\chi}'_k \rangle_{c_1} + \langle \mathcal{P}_0^{1/2}\hat{\chi}''_k, \mathcal{P}_0^{1/2}\hat{\chi}''_k \rangle_{c_1} + \langle \mathcal{P}_0^{1/2}\hat{\chi}'''_k, \mathcal{P}_0^{1/2}\hat{\chi}'''_k \rangle_{c_1} \\ &\geq (2k+1+2\sigma)s \|\hat{\chi}'_k\|_{c_1}^2 + (1+2\sigma)s \|\hat{\chi}''_k\|_{c_1}^2 + (2k+5+2\sigma)s \|\hat{\chi}'''_k\|_{c_1}^2 \\ &= (1+2\sigma)s + 2ks(\|\hat{\chi}'_k\|_{c_1}^2 + \|\hat{\chi}'''_k\|_{c_1}^2) + 4s \|\hat{\chi}'''_k\|_{c_1}^2 \\ &> (1+2\sigma)s + 2ks(1-\delta/k) + 4s \|\hat{\chi}'''_k\|_{c_1}^2, \end{aligned}$$

giving

$$\|\hat{\chi}'''_k\|_{c_1}^2 < \frac{((2k+1+2\sigma)\epsilon + C)\xi}{4s^{1-u}} + \frac{\delta}{2} < \delta$$

for  $s$  large enough. Thus  $\|\hat{\chi}'''_k\|_{c_1}^2 \rightarrow 0$  as  $s \rightarrow \infty$ , and the result follows.  $\square$

**Corollary 4.7.8.** *If  $h$  is a bounded measurable function on  $\mathbb{R}_+$  such that  $h(\rho) \rightarrow 1$  as  $\rho \rightarrow 0$ , then  $\langle h\hat{\chi}_{\mathcal{P},0}, \hat{\chi}_{\mathcal{P},0} \rangle_{c_1} \rightarrow 1$  as  $s \rightarrow \infty$ .*

*Proof.* This follows from Lemma 4.7.7 and Remark 4.7.6-(i).  $\square$

Similar results hold for  $\mathcal{Q}$  and  $\mathcal{W}$ , but they are omitted because they are not used.



---

## Appendix A

# Preliminaries on Stratified Spaces and Global Analysis

---

### A.1 Stratified Spaces

For the reader's convenience, we recall some basics about Thom-Mather stratifications. Here we mainly follow [5, Section 3], which is based on [69].

#### A.1.1 Thom-Mather stratifications

Let  $A$  be a Hausdorff, locally compact and second countable topological space. It is said that  $Y, Z \subset A$  are *equal near* a locally closed subset  $X \subset A$  when  $Y \cap U = Z \cap U$  for some neighborhood  $U$  of  $X$  in  $A$ . Then two maps,  $f : Y \rightarrow B$  and  $g : Z \rightarrow B$ , are *equal near*  $X$  if moreover the restrictions of  $f$  and  $g$  to  $Y \cap U$  are equal.

Consider triples  $(T, \pi, \rho)$ , where  $T$  is an open neighborhood of  $X$ ,  $\pi : T \rightarrow X$  is a continuous retraction, and  $\rho : T \rightarrow [0, \infty)$  is a continuous function satisfying  $\rho^{-1}(0) = X$ . Two such triples,  $(T, \pi, \rho)$  and  $(T', \pi', \rho')$ , are said to be *equal near*  $X$  when  $T = T'$ ,  $\pi = \pi'$  and  $\rho = \rho'$  near  $X$ . This defines an equivalence relation whose equivalence classes are called *tubes* of  $X$  in  $A$ . If  $X$  is open in  $A$ , then  $[(X, \text{id}_X, 0)]$  is its unique tube, called the *trivial tube*.

According to [69, Definiton 1.2.1], a *Thom-Mather stratification* is given by triple  $(A, \mathcal{S}, \tau)$ , where:

- (i)  $A$  is a Hausdorff, locally compact and second countable space,
- (ii)  $\mathcal{S}$  is a partition of  $A$  into locally closed subspaces with the additional structure of smooth ( $C^\infty$ ) manifolds, called *strata*, and
- (iii)  $\tau$  is the assignment of a tube  $\tau_X$  of each  $X \in \mathcal{S}$  in  $A$ ,

such that the following conditions are satisfied with some choice of  $(T_X, \pi_X, \rho_X) \in \tau_X$  for each  $X \in \mathcal{S}$ :

- (iv) For all  $X, Y \in \mathcal{S}$ , if  $X \cap \bar{Y} \neq \emptyset$ , then  $X \subset \bar{Y}$ . The notation  $X \leq Y$  is used in this case, and this defines a partial order relation on  $\mathcal{S}$ . As usual,  $X < Y$  means that  $X \leq Y$  but  $X \neq Y$ .
- (v) If  $Y \neq X$  in  $\mathcal{S}$  and  $T_X \cap T_Y \neq \emptyset$ , then  $X < Y$  and  $(\pi_X, \rho_X) : T_X \cap T_Y \rightarrow X \times \mathbb{R}_+$  is a smooth submersion; in particular,  $\dim X < \dim Y$ .
- (vi) If  $X < Y$  in  $\mathcal{S}$ , then  $\pi_Y(T_X \cap T_Y) \subset T_X$ , and  $\pi_X \pi_Y = \pi_X$  and  $\rho_X \pi_Y = \rho_X$  on  $T_X \cap T_Y$ .

Some important considerations about stratified spaces are the following:

- $A$  is paracompact and normal.
- By the normality of  $A$ , we can also assume that, if  $X, Y \in \mathcal{S}$  and  $T_X \cap T_Y \neq \emptyset$ , then  $X \leq Y$  or  $Y \leq X$ .
- The frontier of a stratum  $X$  equals the union of the strata  $Y < X$ .
- The connected components of each stratum may have different dimensions.
- The connected components of the strata, with the restrictions of the tubes, define an induced Thom-Mather stratification  $A_{\text{con}} \equiv (A, \mathcal{S}_{\text{con}}, \tau_{\text{con}})$ .
- A *weak Thom-Mather stratification* is defined by removing  $\rho_X \pi_Y = \rho_X$  from the condition (vi).

We introduce now some examples of stratified spaces:

- (1) Any smooth manifold is a Thom-Mather stratification with one stratum and the trivial tube.
- (2) Any smooth manifold with boundary is a stratification with two strata, the interior and the boundary. It can be equipped with a Thom-Mather structure by using a collar of the boundary.
- (3) Any subanalytic subset of  $\mathbb{R}^m$  has primary and secondary stratifications [37–39, 43, 50].
- (4) J. Mather [49] has proved that the so called Whitney stratified subspaces of any smooth manifold admit a Thom-Mather structure.

Let  $B \subset A$  be a locally closed subset. Suppose that, for all  $X \in \mathcal{S}$ ,  $X \cap B$  is a smooth submanifold of  $X$ , and that  $B \cap \pi_X^{-1}(X \cap B)$  defines a tube  $\tau_{X \cap B}$  of  $X \cap B$  in  $B$ . Let  $\mathcal{S}|_B = \{X \cap B \mid X \in \mathcal{S}\}$ , and let  $\tau|_B$  be defined by the assignment of

$\tau_{X \cap B}$  to each  $X \cap B \in \mathcal{S}|_B$ . If  $(B, \mathcal{S}|_B, \tau|_B)$  satisfies conditions (i)–(vi), it is said that  $B \equiv (B, \mathcal{S}|_B, \tau|_B)$  is a *Thom-Mather substratification* of  $A$ .

Let  $A' \equiv (A', \mathcal{S}', \tau')$  be another Thom-Mather stratification. A continuous map  $f : A \rightarrow A'$  is called a (*smooth*) *morphism* if, for any  $X \in \mathcal{S}$ , there is some  $X' \in \mathcal{S}'$  such that  $f(X) \subset X'$ , the restriction  $f : X \rightarrow X'$  is smooth, and there are  $(T_X, \pi_X, \rho_X) \in \tau_X$  and  $(T'_{X'}, \pi'_{X'}, \rho'_{X'}) \in \tau'_{X'}$  satisfying  $f(T_X) \subset T'_{X'}$ ,  $f\pi_X = \pi'_{X'}f$  and  $\rho_X = \rho'_{X'}f$ . The continuity of a morphism follows from the other conditions. Morphisms between stratifications form a category with the composition operation; in particular, we have the corresponding concepts of *isomorphism* and *automorphism*.

*Example A.1.1.* Let  $G$  be a compact Lie group acting smoothly on a closed manifold  $M$ . Consider the orbit type stratifications of  $M$  and  $G \backslash M$  [14]. The cocient space  $G \backslash M$  admits a Thom-Mather structure [69, Introduction] because  $G \backslash M$  is locally isomorphic to a semi-algebraic subset of an Euclidean space whose primary and secondary stratifications are equal [10]. Thus, using an invariant smooth partition of unity of  $M$ , like in the Whitney's embedding theorem, it follows that  $G \backslash M$  is isomorphic to a Whitney stratified subspace of some Euclidean space, and therefore it admits a Thom-Mather structure.

### A.1.2 Products of stratifications

The product of two weak Thom-Mather stratifications,  $A$  and  $A'$ , is a weak Thom-Mather stratification  $A \times A' \equiv (A \times A', \mathcal{S}'', \tau'')$  with

$$\begin{aligned} \mathcal{S}'' &= \{ X \times X' \mid X \in \mathcal{S}, X' \in \mathcal{S}' \}, \\ \tau''_{X \times X'} &= [T''_{X \times X'}, \pi''_{X \times X'}, \rho''_{X \times X'}], \end{aligned}$$

where

$$\begin{aligned} T''_{X \times X'} &= T_X \times T'_{X'}, \\ \rho''_{X \times X'}(x, x') &= \rho_X(x) + \rho'_{X'}(x'). \end{aligned}$$

If  $A$  and  $A'$  are Thom-Mather stratifications and the complexity of at least one of them is zero, then  $A \times A'$  is a Thom-Mather stratification, but this is not true when both complexities are positive [69, Section 1.2.9].

*Example A.1.2.* Let  $A = A' = [0, \infty)$ , with the strata  $X = \{0\} < Y = (0, \infty)$ , taking  $T_X = [0, \infty)$ ,  $T_Y = Y$ ,  $\pi_X(x) = 0$ ,  $\pi_Y(y) = y$ ,  $\rho_X(x) = x$  and  $\rho_Y(y) = 0$ . Then the second equality of condition (vi) fails for the strata  $X \times X < X \times Y$  of  $A \times A'$ :

$$\rho''_{X \times X} \pi''_{X \times Y}(x, x') = \rho''_{X \times X}(0, x') = x' \neq x + x' = \rho''_{X \times X}(x, x')$$

for all  $(x, x') \in (0, \infty)^2$ , which is an open dense subset of  $T''_{X \times X} \cap T''_{X \times Y} = T''_{X \times Y} = [0, \infty) \times (0, \infty)$ , contradicting (vi).

Thus another choice of  $\rho''_{X \times X'}$  is needed to get the second equality of condition (vi). For instance,  $\rho''_{X \times X'} = \max\{\rho_X, \rho_{X'}\}$  satisfies that condition, but it is not smooth on the intersection of the strata with  $T''_{X \times X'}$ . To solve this problem, pick up a function  $h : [0, \infty)^2 \rightarrow [0, \infty)$  that is continuous, homogeneous of degree one, smooth on  $\mathbb{R}_+^2$ , with  $h^{-1}(0) = \{(0, 0)\}$ , and such that, for some  $C > 1$ , we have  $h(r, s) = \max\{r, s\}$  if  $C \min\{r, s\} < \max\{r, s\}$ . Then  $A \times A'$  becomes a Thom-Mather stratification by setting  $\rho''_{X \times X'}(x, x') = h(\rho_X(x), \rho_{X'}(x'))$ ; it will be called a *product* of  $A$  and  $A'$ .

## A.2 Some Results of Global Analysis

Here we recall some results of Global Analysis on manifolds that play a fundamental role in the arguments used to prove the main theorems (see Section 1.6) presented in this thesis. Just the statements, without proofs, are included.

**Proposition A.2.1.** [5, Proposition 14.2] *Let  $(E, d)$  be an elliptic complex on a Riemannian manifold  $M$ . Let  $\{U_a\}$  be a finite open covering of  $M$ , and let  $\{f_a\}$  be a smooth partition of unity on  $M$  subordinated to  $\{U_a\}$  such that each  $[[d, f_a]]$  is bounded. Assume also that there is another family  $\{\tilde{f}_a\} \subset C^\infty(M)$  such that  $\tilde{f}_a$  and  $[[d, \tilde{f}_a]]$  are bounded,  $\tilde{f}_a = 1$  on  $\text{supp } f_a$ , and  $\text{supp } \tilde{f}_a \subset U_a$ . For each  $a$ , let  $(E^a, d^a)$  be an elliptic complex on a Riemannian manifold  $M_a$ , let  $V_a \subset M_a$  be an open subset, and let  $\zeta_a : (E|_{U_a}, d) \rightarrow (E^a|_{V_a}, d^a)$  be a quasi-isometric isomorphism of elliptic complexes over  $\xi_a : U_a \rightarrow V_a$ . Then the following properties hold:*

- (i)  $\mathcal{D}(d_{\min/\max}) = \{u \in L^2(E) \mid \zeta_a(f_a u) \in \mathcal{D}(d_{\min/\max}^a) \forall a\}$ .
- (ii) If  $d_{\min/\max}^a$  is discrete for all  $a$ , then  $d_{\min/\max}$  is discrete.

**Proposition A.2.2.** [5, Proposition 14.3] *With the notation of Proposition A.2.1, suppose that every  $d_{\min/\max}^a$  is discrete, and therefore  $d_{\min/\max}$  is also discrete. Let*

$$0 \leq \lambda_{\min/\max,0}^a \leq \lambda_{\min/\max,1}^a \leq \dots, \quad 0 \leq \lambda_{\min/\max,0} \leq \lambda_{\min/\max,1} \leq \dots$$

*denote the eigenvalues, repeated according to their multiplicities, of the Laplacians  $\Delta_{\min/\max}^a$  and  $\Delta_{\min/\max}$  defined by  $d_{\min/\max}^a$  and  $d_{\min/\max}$ , respectively. Suppose that, for all  $a$ , there is some<sup>1</sup>  $\theta_a > 0$  such that  $\liminf_k \lambda_{\min/\max,k}^a k^{-\theta_a} > 0$ . Then we have  $\liminf_k \lambda_{\min/\max,k} k^{-\theta} > 0$  with  $\theta = \min_a \theta_a$ .*

---

<sup>1</sup>The notation  $\theta_{a,\min/\max}$  would be more correct, but, for the sake of simplicity, reference to the maximum/minimum i.b.c. is omitted here.

**Theorem A.2.3.** [9, Theorem 2] *Let  $(M, g)$  be an open oriented Riemannian manifold and  $E$  a vector bundle over  $M$ . Let  $P_0 : C_0^\infty(M, E) \rightarrow C_0^\infty(M, E)$  be a non-negative symmetric differential operator, and  $P : L^2(M, E) \rightarrow L^2(M, E)$  a non-negative self-adjoint extension of  $P_0$ . Then the heat operator  $e^{-tP}$  satisfies the following properties:*

- (i)  $e^{-tP}$  has a  $C^\infty$ -kernel in  $C^\infty((0, \infty) \times M \times M, E \boxtimes E^*)$ , denoted by  $k_P(t, p, q)$ .
- (ii) If  $K_1$  and  $K_2$  are compact subsets of  $M$  such that  $K_1 \cap K_2 = \emptyset$ , then

$$\|k_P(t, p, q)\|_{C^r(K_1 \times K_2, E \boxtimes E^*)} = O(t^n) \quad \text{as } t \rightarrow 0,$$

for all  $r, n \in \mathbb{N}$ .

**Theorem A.2.4.** (Atiyah-Bott) [59, Theorem 10.12] *Let  $(\zeta, \psi)$  be a geometric endomorphism of a Dirac complex over a compact oriented manifold of dimension  $n$ . Then the Lefschetz number of  $(\zeta, \psi)$  is given by*

$$L(\zeta, \psi) = \sum_{q \in \text{Fix}(\psi)} \sum_{r=0}^n (-1)^r \frac{\text{tr}(\zeta_r(q))}{|\det(1 - T_q \psi)|}.$$

**Corollary A.2.5.** (Lefschetz) [59, Example 10.14] *Let  $\psi : M \rightarrow M$  be a smooth map on a compact oriented manifold  $M$ . Then the Lefschetz number of  $\psi$  is given by*

$$L(\psi) = \sum_{q \in \text{Fix}(\psi)} \text{sign } \det(1 - T_q \psi).$$



# Resumo

---

Os obxectos estudados nesta tese son os espazos estratificados de Thom-Mather. Tal concepto foi introducido por René Thom e John Mather arredor de 1970. Posteriormente, as estratificacións foron profundamente estudadas por Mark Goresky e Robert MacPherson, empregando a homoloxía intersección.

Por definición, os espazos estratificados de Thom-Mather admiten unha partición en variedades  $C^\infty$  chamadas estratos, que en xeral poderán ter diferentes dimensións. Os estratos péganse entre si baixo certas condicións técnicas que involucran fibrados cónicos. Isto dá lugar a unha descrición local destes espazos usando cartas locais cónicas, que xeneralizan ás cartas usuais en variedades. As estratificacións de Thom-Mather tamén admiten diversos tipos de métricas: métricas adaptadas xerais, métricas adaptadas e métricas adaptadas de tipo cónico.

Os obxectivos principais da investigación en estratificacións de Thom-Mather consisten en demostrar resultados xeométricos e topolóxicos, xeneralizando ou adaptando a este contexto teoremas e propiedades clásicas de variedades con borde. Nos estratos pódense considerar certos operadores diferenciais actuando nos correspondentes espazos de formas diferenciais, ou sobre as seccións diferenciáveis doutros fibrados vectoriais. O seu estudo é unha técnica moi potente para a obtención de moitas propiedades dos espazos estratificados. Polo tanto, a Análise Funcional e as Ecuacións en Derivadas Parciais, particularmente a ecuación do calor e a ecuación de onda, son ferramentas fundamentais neste campo. A área das Matemáticas que aplica a Teoría de Operadores para obter resultados xeométricos e topolóxicos en variedades e outros obxectos relacionados denomínase Análise Global.

Introdúcese a continuación o contexto xeral que se considera ao longo desta tese, explicado detalladamente no capítulo 1. Sexa  $M$  un estrato dunha estratificación compacta  $A$  equipado cunha métrica adaptada xeral  $g$ . Tal noción é lixeiramente máis xeral ca das métricas adaptadas de Nagase e Brasselet-Hector-Saralegi. En particular,  $g$  ten un tipo xeral, que é unha extensión do tipo das métricas adaptadas. Asumírase certa condición no tipo xeral, e entón dirase que  $g$  é boa. Considerarase a condición de fronteira ideal máxima/mínima  $d_{\max/\min}$  do subcomplexo de de Rham das formas diferenciais en  $M$  con soporte compacto, no sentido de Brüning-Lesch. A

cohomoloxía e o laplaciano de  $d_{\max/\min}$  denótanse por  $H_{\max/\min}^*(M)$  e  $\Delta_{\max/\min}$ , respectivamente. O primeiro dos teoremas principais desta tese establece que  $\Delta_{\max/\min}$  ten espectro discreto, que ademais satisfai unha versión débil da fórmula asintótica de Weyl. O segundo teorema principal é unha versión das desigualdades de Morse, no que se utiliza  $H_{\max/\min}^*(M)$  e o que se chamarán funcións de rel-Morse. Un ingrediente fundamental para a demostración de ambos teoremas é a versión para  $d_{\max/\min}$  da perturbación de Witten do complexo de de Rham, que é un método moi potente para a obtención das desigualdades de Morse en variedades mediante un punto de vista analítico e físico. Os argumentos usados para probar ambos teoremas están incluídos no capítulo 2. O terceiro teorema importante desta tese é unha versión da fórmula da traza de Lefschetz en espazos estratificados con singularidades illadas, demostrado no capítulo 3 e onde a perturbación de Witten xoga tamén un papel fundamental. Outro ingrediente esencial para a obtención de todos estes resultados é o estudo de certa perturbación do oscilador harmónico de Dunkl, sobre o que trata o capítulo 4.

A condición de que  $g$  sexa boa é suficientemente xeral no sentido indicado a continuación. Sexa  $A$  unha pseudovariedade estratificada con estrato regular  $M$ . Considérese a súa homoloxía intersección  $I^{\bar{p}}H_*(A)$  con perversidade  $\bar{p}$ ; en particular, as perversidades intermedia inferior e superior denótanse por  $\bar{m}$  e  $\bar{n}$ , respectivamente. Entón para toda perversidade  $\bar{p} \leq \bar{m}$  existe en  $M$  unha boa métrica adaptada asociada a ela que satisfai o isomorfismo de Nagase  $H_{\max}^r(M) \cong I^{\bar{p}}H_r(A)^*$  ( $r \in \mathbb{N}$ ). Se  $M$  é orientable e  $\bar{p} \geq \bar{n}$ , tamén se obtén que  $H_{\min}^r(M) \cong I^{\bar{p}}H_r(A)$ . Polo tanto, as versións das desigualdades de Morse e da fórmula da traza de Lefschetz que se presentan nesta tese poden ser descritas en termos de  $I^{\bar{p}}H_*(A)$ .

## 1 Condicións de fronteira ideal do complexo de de Rham

A seguinte notación empregárase en referencia a un operador linear  $T$  densamente definido nun espazo de Hilbert separable. O seu dominio e rango denótanse por  $D(T)$  e  $R(T)$ , respectivamente. Se  $T$  é esencialmente autoadxunto a súa clausura escríbese  $\bar{T}$ . Se  $T$  é autoadxunto o seu smooth core é  $D^\infty(T) := \bigcap_{m=1}^\infty D(T^m)$ , e o seu espectro denótase por  $\sigma(T)$ .

Un complexo de Hilbert  $(D, \mathbf{d})$  é un complexo diferencial de lonxitude finita determinado por un operador pechado e densamente definido  $\mathbf{d}$  nun espazo de Hilbert separable graduado  $\mathfrak{H}$  [15]. Logo o operador  $\mathbf{D} = \mathbf{d} + \mathbf{d}^*$ , con  $D(\mathbf{D}) = D(\mathbf{d}) \cap D(\mathbf{d}^*)$ , é autoadxunto en  $\mathfrak{H}$  e, polo tanto, o laplaciano  $\Delta = \mathbf{D}^2 = \mathbf{d}\mathbf{d}^* + \mathbf{d}^*\mathbf{d}$  é tamén autoadxunto. Ademais  $D^\infty(\Delta)$  é un subcomplexo de  $(D, \mathbf{d})$  coa mesma homoloxía [15, Teorema 2.12]. Dise que  $D^\infty(\Delta)$  é o smooth core de  $\mathbf{d}$ .

Dada unha variedade riemanniana  $M$ , sexa  $\Omega_0(M)$  o espazo de formas diferenciáveis con soporte compacto, e  $L^2\Omega(M)$  o espazo de hilbert graduado das formas

diferenciais de cadrado integrable. Sexan  $d$  e  $\delta$  a diferencial e a codiferencial de de Rham actuando en  $\Omega_0(M)$ , e considérense  $D = d + \delta$  e  $\Delta = D^2 = d\delta + \delta d$  (o laplaciano). Toda extensión como complexo de Hilbert  $\mathfrak{d}$  de  $d$  en  $L^2\Omega(M)$  denomínase condición de fronteira ideal (i.b.c. segundo as siglas en inglés) [15], dando lugar a extensións autoadxuntas  $\mathbf{D}$  e  $\mathbf{\Delta}$  de  $D$  e  $\Delta$  en  $L^2\Omega(M)$ . Existe unha máxima/mínima i.b.c., sendo  $d_{\max} = \delta^*$  e  $d_{\min} = \bar{d}$ , que induce extensións autoadxuntas  $D_{\max/\min}$  e  $\Delta_{\max/\min}$  de  $D$  e  $\Delta$ . Se  $M$  é orientable,  $\Delta_{\max}$  correspóndese con  $\Delta_{\min}$  mediante o operador estrela de Hodge. As cohomoloxías correspondentes  $H_{\max/\min}(M)$  son invariantes cuasi-isométricos de  $M$ ; de feito,  $H_{\max}(M)$  é a  $L^2$ -cohomoloxía usual  $H_{(2)}(M)$  [18]. Isto permite definir versións dos números de Betti e da característica de Euler,  $\beta_{\max/\min}^r = \beta_{\max/\min}^r(M)$  and  $\chi_{\max/\min} = \chi_{\max/\min}(M)$  (asumindo dimensión finita nas cohomoloxías correspondentes). Estes conceptos poden ser definidos para complexos elípticos arbitrarios [15]. Ademais é ben coñecido que  $d_{\min} = d_{\max}$  se  $M$  é variedade completa. Logo as i.b.c. son interesantes no caso en que  $M$  non é completa. Por exemplo, se  $M$  é o interior dunha variedade riemanniana compacta  $N$  con  $\partial N \neq \emptyset$ , defínese  $d_{\max/\min}$  tomando condicións de fronteira absolutas/relativas. En xeral, asumiremos que  $M$  é estrato dunha estratificación compacta  $A$  [49, 50, 67, 69], equipado cunha xeneralización do concepto de métricas adaptadas considerado en [13, 53, 54]. Poderase asumir tamén que  $\bar{M} = A$ , e dirase entón que  $M$  é o estrato regular de  $A$ .

## 2 Espazos estratificados

Pódese dicir, dun xeito non preciso, que unha estratificación de Thom-Mather é un espazo Hausdorff, localmente compacto e segundo numerable  $A$  provisto dunha partición en variedades  $C^\infty$  (chamadas estratos) tal que se verifican certas condicións [49, 67]. En particular, establecendo que  $X \leq Y$  se  $X \subset \bar{Y}$ , tense unha relación de orde na familia de estratos. Con respecto a esta orde, a profundidade dun estrato  $X$  é a lonxitude máxima de cadeas de estratos menores ou iguais ca  $X$ . A profundidade de  $A$  é o supremo das profundidades dos estratos. Nesta sección indícase como os estratos de  $A$  están pegados entre si, describindo tamén os morfismos/isomorfismos de estratificacións e, particularmente, o grupo de automorfismos  $\text{Aut}(A)$ . Os procedementos xerais fanse habitualmente mediante indución na profundidade. Así, se  $\text{depth } A = 0$ , tense que  $A$  é unha variedade  $C^\infty$  e  $\text{Aut}(A)$  consiste no seu grupo de difeomorfismos.

Dado  $k \in \mathbb{Z}_+$ , asúmase que todo espazo estratificado  $L$  con  $\text{depth } L < k$  está ben descrito, así como  $\text{Aut}(L)$ . Se  $L$  é compacto, o cono con enlace  $L$  consiste en  $c(L) = (L \times [0, \infty))/(L \times \{0\})$ , que ten por vértice  $a * = L \times \{0\} \in c(L)$ . Sexan  $L'$  outra estratificación compacta de profundidade  $< k$ , e  $\phi : L \rightarrow L'$  un morfismo. Sexa

$c(\phi) : c(L) \rightarrow c(L')$  a aplicación inducida por  $\phi \times \text{id} : L \times [0, \infty) \rightarrow L' \times [0, \infty)$ ; en particular, obtense o grupo  $c(\text{Aut}(L)) = \{c(\phi) \mid \phi \in \text{Aut}(L)\}$ . Establécese que  $c(\emptyset) = \{*\}$  para a estratificación baleira e  $c(\emptyset) = \text{id}$  para a aplicación baleira. Dado un enlace  $L$  de profundidade  $k - 1$ , o cono  $c(L)$  utilízase como modelo de espazo estratificado de profundidade  $k$ , que ten por estratos a  $\{*\}$  e ás variedades  $Y \times \mathbb{R}_+$  tales que  $Y$  é estrato de  $L$ . A proxección sobre o segundo factor  $L \times [0, \infty) \rightarrow [0, \infty)$  define unha función  $c(\text{Aut}(L))$ -invariante  $\rho : c(L) \rightarrow [0, \infty)$ , chamada función radial. As restricións de  $\rho$  aos estratos son aplicacións  $C^\infty$ . Un fibrado cónico consiste nun fibrado  $T$  sobre unha variedade  $X$  que ten por fibra estándar  $c(L)$  e por grupo estrutural  $c(\text{Aut}(L))$ . Logo  $\rho$  induce unha función radial en  $T$  denotada tamén por  $\rho$ , e o vértice de  $c(L)$  define a sección vértice de  $T$ , cúa imaxe se identifica con  $X$ . Ademais a estrutura estratificada definida en  $c(L)$  permite definir outra estrutura estratificada en  $T$ , de maneira que  $X$  se converte no estrato vértice.

Todo estrato  $X$  dunha estratificación  $A$  de profundidade  $k$  ten unha veciñanza aberta (denominada tubo representativo) isomorfa a unha veciñanza aberta de  $X$  nalgún fibrado cónico  $T_X$  sobre  $X$  (coas obvias restricións da estrutura estratificada a subconxuntos abertos). A fibra estándar de  $T_X$  é da forma  $c(L_X)$ , para algunha estratificación compacta  $L_X$  (o enlace de  $X$ ) con  $\text{depth } L_X < \text{depth } A$ . O vértice e a función radial de  $c(L_X)$  denótanse por  $*_X$  e  $\rho_X$ , respectivamente. Dúas veciñanzas de  $X$  deste tipo representan ao mesmo tubo se a súa estrutura é igual nalgunha veciñanza de  $X$  máis pequena. Obsérvase que  $X$  é aberto en  $A$  se e só se  $L_X = \emptyset$ .

Un morfismo (diferenciable) entre dúas estratificacións é unha aplicación continua que envía cada estrato a outro estrato, tal que as súas restricións aos estratos son aplicacións  $C^\infty$  e as súas restricións a tubos representativos suficientemente pequenos son restricións de morfismos de fibrados cónicos. Así, os isomorfismos e automorfismos de estratificacións teñen o significado usual. Isto completa a súa descrición porque a profundidade é localmente finita, como consecuencia da compacidade local.

A dimensión (topolóxica) dunha estratificación  $A$  é igual ao supremo das dimensións dos seus estratos. Poderá ser infinita, mais é localmente finita. A codimensión dun estrato  $X$  é  $\dim A - \dim X$ . Os resultados principais desta tese consideran estratificacións compactas. Non obstante, nas demostracións tamén se usarán estratificacións non compactas. En todo caso, só se tratarán estratificacións de dimensión finita. Se modificamos a descrición anterior de  $A$  esixindo que en cada paso inductivo só se poidan tomar estratificacións que non teñan estratos de codimensión 1, dirase que  $A$  é unha pseudovariedade estratificada.

Un subconxunto localmente pechado  $B \subset A$  é unha subestratificación de  $A$  se as restricións aos estratos e aos tubos de  $B$  definen nel unha estrutura estratificada. Suceque que  $A$  pode ser restrinxida a calquera subconxunto aberto, a calquera unión localmente pechada de estratos e á clausura de calquera estrato. Se ademais existen

tubos representativos de  $A$  cuas restricións a  $B$  teñen as mesmas fibras sobre os puntos de  $B$  dise que  $B$  é saturado.

Sexa  $x$  un punto do estrato  $X$  de dimensión  $m_X$  nunha estratificación  $A$ . Unha trivialización local de  $T_X$  nunha veciñanza aberta  $U$  de  $x$  define unha carta  $O \equiv O'$  de  $A$ , para algún aberto  $O' \subset \mathbb{R}^{m_X} \times c(L_X)$ . Pódese asumir que  $O' = U' \times c_\epsilon(L_X)$ , onde  $U'$  é veciñanza aberta de  $0$  en  $\mathbb{R}^{m_X}$  e  $c_\epsilon(L_X)$  é o subconxunto de  $c(L_X)$  determinado pola condición  $\rho_X < \epsilon$ , con  $\epsilon > 0$ . Dise que a carta está centrada en  $x$  se  $x \equiv (0, *_{X,0}) \in O'$ . O concepto correspondente de atlas ten o significado usual. Estas nocións xeneralízanse da maneira seguinte. Todo produto finito de estratificacións ten unha estrutura estratificada non canónica; en particular, todo produto finito de conos é isomorfo a un cono [5, Lema 3.8]. Ademais  $\text{Aut}(P) \times \text{Aut}(Q)$  está canonicamente embebido en  $\text{Aut}(P \times Q)$  para calesquera estratificacións  $P$  e  $Q$ . Logo ten sentido considerar a descomposición  $c(L_X) \cong \prod_{i=1}^{a_X} c(L_{X,i})$  ( $a_X \in \mathbb{N}$ ), sendo  $L_{X,i}$  estratificacións compactas. O vértice e a función radial de cada  $c(L_{X,i})$  denótanse por  $*_{X,i}$  e  $\rho_{X,i}$ , respectivamente. Polo tanto, pódense considerar tubos representativos xerais dados por fibrados  $T_X$  con fibra estándar  $\prod_{i=1}^{a_X} c(L_{X,i})$  e grupo estrutural  $\prod_{i=1}^{a_X} c(\text{Aut}(L_{X,i}))$ . Isto dá lugar á definición de cartas xerais  $O \equiv O'$  arredor de  $x$ , para certos abertos  $O' \subset \mathbb{R}^{m_X} \times \prod_{i=1}^{a_X} c(L_{X,i})$ . Dise que a carta xeral está centrada en  $x$  se  $x \equiv (0, *_{X,1}, \dots, *_{X,a_X}) \in O'$ . Coma antes, pódese asumir que  $O' = U' \times \prod_{i=1}^{a_X} c_\epsilon(L_{X,i})$ , con  $\epsilon > 0$ . Sexa  $\rho_{X,0}$  a función norma en  $\mathbb{R}^{m_X}$ . A función  $\rho = (\rho_{X,0}^2 + \dots + \rho_{X,a_X}^2)^{1/2}$  chámase función radial de  $\mathbb{R}^{m_X} \times \prod_{i=1}^{a_X} c(L_{X,i})$ , aínda que cando  $m_X = 0$ ,  $\rho$  non é función radial para ningunha estrutura cónica de  $\prod_{i=1}^{a_X} c(L_{X,i})$  [5, exemplo 3.6 e demostración do Lema 3.8]. Unha familia de cartas xerais recubriendo  $A$  denomínase atlas xeral.

*Exemplo 1.2.1.* A figura 1.2.1 (tomada de [35]) ilustra unha estratificación compacta que ten catro estratos. Constrúese “estrangulando” ata un punto  $x$  (estrato de dimensión 0) unha sección meridiana dun toro usual, e enchendo o burato que queda no medio cun disco (estrato de dimensión 2). A liña fronteira entre o toro e o disco é un estrato de dimensión 1. A parte regular do toro é outro estrato bidimensional. Non hai ningún estrato denso, polo que non se existe estrato regular. Na figura indícanse dúas cartas, centradas nos puntos  $x$  e  $y$ , respectivamente. A carta centrada en  $x$  ten factor euclidiano trivial, mentres que o factor cónico da carta centrada en  $y$  ten un enlace formado por tres puntos.

Poderase supoñer que os estratos de  $A$  son conexos. Sexa  $M$  estrato de dimensión  $n$  de  $A$ . Posto que a estrutura estratificada de  $A$  é restrinxible a  $\overline{M}$ , pódese asumir sen perda de xeneralidade que  $\overline{M} = A$  (calquera outro estrato é  $< M$ ); en particular,  $\text{depth } A = \text{depth } M$  e  $\dim A = n$ . Dise que  $A$  é unha estratificación orientable se  $M$  é variedade orientable. Coa notación introducida previamente, para toda carta



Figura 1.2.1: Cartas nunha estratificación compacta

$O \equiv O'$  centrada en  $x$  tense que  $M \cap O \equiv M' \cap O'$ , onde  $M' = \mathbb{R}^{m_X} \times N \times \mathbb{R}_+$  e  $N$  é estrato denso de  $L_X$ . No caso dunha carta xeral  $O \equiv O'$  centrada en  $x$  sucede que  $M \cap O \equiv M' \cap O'$ , con  $M' = \mathbb{R}^{m_X} \times \prod_{i=1}^{a_X} (N_i \times \mathbb{R}_+)$ , sendo cada  $N_i$  estrato denso de  $L_{X,i}$ . Usarase a notación  $k_{X,i} = \dim N_i + 1$ .

### 3 Métricas adaptadas xerais

Unha métrica adaptada xeral  $g$  en  $M$  defínese por indución na profundidade. Se  $\text{depth } M = 0$ , calquera métrica riemanniana é adaptada xeral. Supoñamos agora que  $\text{depth } M > 0$  e que as métricas adaptadas xerais están ben definidas para calquera estrato de menor profundidade. Dada unha carta xeral  $O \equiv O'$ , consideremos unha métrica adaptada xeral  $\tilde{g}_i$  en cada  $N_i$  ( $\text{depth } N_i < \text{depth } M$ ), e sexa  $g_i = \rho_{X,i}^{2u_{X,i}} \tilde{g}_i + (d\rho_{X,i})^2$  en  $N_i \times \mathbb{R}_+$  para algún  $u_{X,i} > 0$ . Denotemos por  $g_0$  á métrica euclidiana de  $\mathbb{R}^{m_X}$ . Entón  $g$  será unha métrica adaptada xeral se, para calquera carta xeral, tense que  $g|_O$  é cuasi-isométrica a  $(\sum_{i=0}^{a_X} g_i)|_{O'}$ . En tal caso dise que a correspondencia  $X \mapsto u_X := (u_{X,1}, \dots, u_{X,a_X}) \in \mathbb{R}_+^{a_X}$  é o tipo xeral de  $g$ . Tamén se dirá que a carta xeral é compatible con  $g$  (ou co seu tipo xeral).

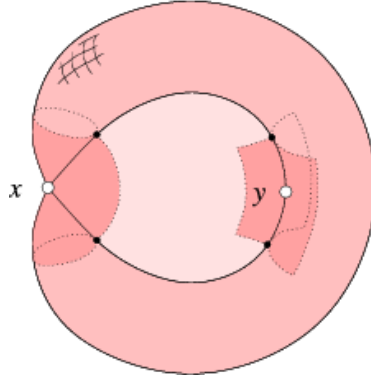
Non obstante, unha métrica adaptada xeral non determina completamente o seu tipo xeral. En efecto, supoñamos que  $u_{X,i} = u_{X,j} = 1$  para un par de índices  $i \neq j$ . Tomemos  $c(L_{X,i}) \times c(L_{X,j}) \equiv c(L)$ , con función radial  $\rho$ , para certa estratificación  $L$ . Así,  $N_i \times \mathbb{R}_+ \times N_j \times \mathbb{R}_+ \equiv N \times \mathbb{R}_+$ , sendo  $N$  o estrato denso de  $L$ . Ademais existirá unha métrica adaptada xeral  $\tilde{g}$  en  $N$  tal que  $g_i + g_j$  é cuasi-isométrica a  $\rho^2 \tilde{g} + (d\rho)^2$  mediante a identidade anterior. Polo tanto, pódense omitir  $u_{X,i}$  ou  $u_{X,j}$  en  $u_X$ , de maneira que se obtén un tipo (xeral) diferente para  $g$ . Isto non se poderá facer se  $u_{X,i} = u_{X,j} \neq 1$ .

Ao longo desta tese, cando na definición de métrica adaptada xeral se require que en cada paso inductivo o tipo xeral cumpra  $u_{X,i} \leq 1$  para todo  $X < M$  e  $i = 1, \dots, a_X$ , dirase que a métrica adaptada xeral é boa. Por outra banda, se modificamos a definición esixindo que en cada paso inductivo se teña  $a_X = 1$  e  $u_X$  dependa unicamente de  $k := k_{X,1} = \text{codim } X$  para todo  $X < M$ , estarémosos restrinxindo ao contexto das métricas adaptadas consideradas en [13, 53, 54]. Nese caso, as cartas xerais compatibles cun tipo xeral serán simplemente cartas. Tomando  $u_k = u_X \equiv u_{X,1} \in \mathbb{R}_+$ , a condición de que a métrica adaptada sexa boa significa que  $u_k \leq 1$ , para todo  $k$ , en cada paso inductivo. En [13, 53, 54] asúmese que  $A$  é unha pseudovariedade estratificada, polo que o tipo de  $g$  pódese denotar por  $\hat{u} = (u_2, \dots, u_n)$ . Tal  $\hat{u}$  está determinado por  $g$ . En particular, impondo a condición  $u_k = 1$  para todo  $k$  en cada paso inductivo, obtéñense as métricas adaptadas de tipo cónico que se consideran en [18–20]. É importante distinguir as sutilezas da definición dos tres termos empregados: métricas adaptadas xerais, métricas adaptadas e métricas adaptadas de tipo cónico. A clase das (boas) métricas adaptadas xerais é conservada por produtos, ao igual cá clase das métricas adaptadas de tipo cónico, mais a clase das métricas adaptadas non ten tal propiedade. A existencia de métricas adaptadas xerais con calquera posible tipo xeral pode ser demostrada do mesmo xeito ca no caso de métricas adaptadas [53, Lema 4.3], [13, Apéndice].

Ao igual que en [5], o prefixo “rel-” fará referencia a que se impón certa condición na intersección de  $M$  coas veciñanzas pequenas arredor dos puntos de  $\overline{M}$ , ou que algún concepto pode ser descrito usando tales interseccións.

Consideremos o estrato denso  $M$  equipado cunha métrica adaptada xeral  $g$ , con tipo xeral  $X \mapsto u_X$ . A completión métrica rel-local  $\widehat{M}$  de  $M$  consiste no subespazo de puntos da completión métrica que están representados por sucesións de Cauchy converxendo en  $\overline{M}$  ( $\widehat{M}$  é a completión métrica de  $M$  se  $\overline{M}$  é compacta). A figura 1.3.1 ilustra dito concepto. Os límites de sucesións de Cauchy definen unha aplicación continua  $\text{lím} : \widehat{M} \rightarrow \overline{M}$ . As propiedades que seguen poden ser probadas de xeito análogo ao do caso de métricas de tipo cónico [5, Proposición 3.20-(i),(ii)].  $\widehat{M}$  ten unha única estrutura estratificada con estratos conexos tal que  $\text{lím} : \widehat{M} \rightarrow \overline{M}$  é un morfismo cuí as restricións aos estratos son difeomorfismos locais. Ademais  $g$  é tamén unha métrica adaptada xeral con respecto a  $\widehat{M}$ .

## 4 Funcións de rel-Morse

Unha función  $f \in C^\infty(M)$  dise que é rel-admisíble se as funcións  $f$ ,  $|df|$  e  $|\text{Hess } f|$  son rel-acotadas. Pode suceder que  $f$  non teña extensión continua a  $\overline{M}$ , pero si que se extenderá continuamente a  $\widehat{M}$ . Logo ten sentido dicir que un punto  $x \in \widehat{M}$  é rel-



Figura 1.3.1: O espazo estratificado  $\widehat{M}$ .

crítico de  $f$  se  $\liminf |df(y)| = 0$  cando  $y \rightarrow x$  en  $\widehat{M}$ , sendo  $y \in M$ . O conxunto de puntos rel-críticos de  $f$  denótase por  $\text{Crit}_{\text{rel}}(f)$ . Dirase que  $f$  é función de rel-Morse se é rel-admisíbel e presenta a seguinte descrición arredor de cada  $x \in \text{Crit}_{\text{rel}}(f)$ :

- existe unha carta xeral  $O \equiv O'$  de  $\widehat{M}$  centrada en  $x$  e compatible con  $g$  tal que  $M \cap O \equiv M' \cap O'$ , con  $M' = \mathbb{R}^{m_X} \times \prod_{i=1}^{a_X} (N_i \times \mathbb{R}_+)$  e onde  $X$  é o estrato de  $\widehat{M}$  que contén a  $x$ ; e
- $f|_{M \cap O} \equiv f(x) + \frac{1}{2}(\rho_+^2 - \rho_-^2)|_{M' \cap O'}$ , sendo  $\rho_{\pm}$  a función radial do produto  $\mathbb{R}^{m_{\pm}} \times \prod_{i \in I_{\pm}} c(L_{X,i})$ , para certa expresión  $m_X = m_+ + m_-$  ( $m_{\pm} \in \mathbb{N}$ ) e certa partición de  $\{1, \dots, a_X\}$  dada por conxuntos  $I_{\pm}$ .

Dado que neste contexto non contamos cun lema de rel-Morse, impónse a anterior descrición local en lugar de esixir que  $\text{Hess } f$  sexa “rel-non-dexenerado” arredor dos puntos rel-críticos. Para cada  $r = 0, \dots, n$  defínense os números dados por

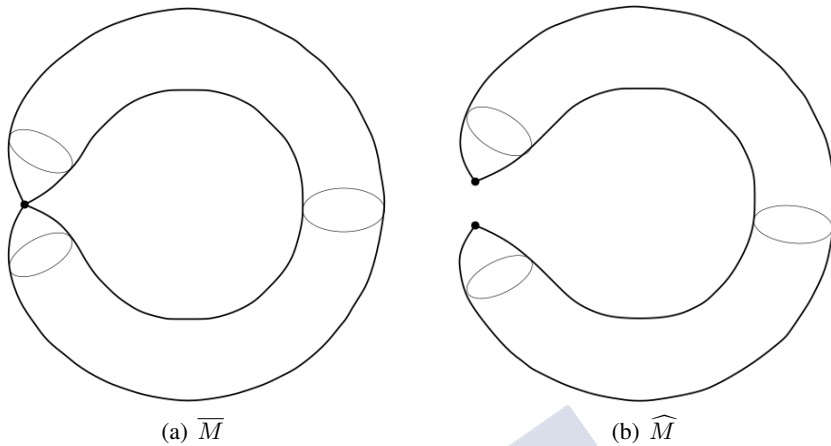
$$\nu_{x, \text{max/min}}^r = \sum_{(r_1, \dots, r_{a_X})} \prod_{i=1}^{a_X} \beta_{\text{max/min}}^{r_i}(N_i), \quad (1.4.1)$$

onde  $(r_1, \dots, r_{a_X})$  percorre o subconxunto de  $\mathbb{N}^{a_X}$  determinado por

$$\left. \begin{aligned}
 r &= m_- + \sum_{i=1}^{a_X} r_i + |I_-|, \\
 r_i &< \frac{k_{X,i}-1}{2} + \frac{1}{2u_{X,i}} \quad \text{se } i \in I_+ \\
 r_i &\geq \frac{k_{X,i}-1}{2} + \frac{1}{2u_{X,i}} \quad \text{se } i \in I_- \\
 r_i &\leq \frac{k_{X,i}-1}{2} - \frac{1}{2u_{X,i}} \quad \text{se } i \in I_+ \\
 r_i &> \frac{k_{X,i}-1}{2} - \frac{1}{2u_{X,i}} \quad \text{se } i \in I_-
 \end{aligned} \right\} \begin{array}{l} \text{para } \nu_{x,\max}^r, \\ \text{para } \nu_{x,\min}^r. \end{array}$$

Se sucede que  $a_X = 0$  en (1.4.1), o termo  $\mathbb{N}^0$  consistir6 na sucesi3n baleira, obt6ndose as6 que  $\nu_{x,\max/\min}^r = \delta_{r,m_-}$  ao aplicar a convenci3n de que o valor dun produto baleiro 6 igual a 1. Def6nese  $\nu_{\max/\min}^r = \sum_x \nu_{x,\max/\min}^r$ , con  $x$  percorrendo  $\text{Crit}_{\text{rel}}(f)$ . A existencia de funci3ns de rel-Morse para m6tricas adaptadas xerais ded6cese de xeito an6logo ao do caso de m6tricas adaptadas [5, Proposici3n 4.9].

## 5 F6rmula da traza de Lefschetz

Sexa  $A$  unha estratificaci3n compacta orientable de dimensi3n  $n$  con singularidades illadas e equipada cunha boa m6trica adaptada  $g$  na s6a parte regular  $\text{reg}(A) = M$ . En particular, se  $n > 1$ ,  $A$  6 unha pseudovarietade orientable con  $\text{depth } A = 1$ . Consid6rese un morfismo de estratificaci3ns  $\psi : A \rightarrow A$ . L6mbrese que, por definici3n de morfismo (secci3n 2), tense que  $\psi|_M$  6 aplicaci3n  $C^\infty$ . Sexa  $\psi^*$  o endomorfismo de  $(\Omega(M), d)$  inducido por  $\psi$ . Denotarase por  $\text{Fix}(\psi)$  ao conxunto de puntos fixos de  $\psi$ .

Todo punto singular 6 un estrato de dimensi3n cero de  $A$ . Ent3n para calquera  $q \in \text{sing}(A) = A \setminus M$  existir6 unha carta

$$O_q \equiv O'_q = \{0\} \times c_{\epsilon_q}(L_q) \equiv c_{\epsilon_q}(L_q)$$

centrada en  $q$  tal que  $\text{depth } L_q = 0$  (v6xase a secci3n 2). Isto significa que todo enlace  $L_q$  6 unha variedade compacta diferenciable. Ademais esta estrutura local arredor dos puntos singulares implica que, para todo  $q \in \text{Fix}(\psi) \cap \text{sing}(A)$ , o morfismo  $\psi$  toma a forma

$$\psi(\rho, x) = (\rho F_q(\rho, x), G_q(\rho, x)) \tag{1.5.1}$$

en calquera carta c3nica  $O_q \equiv c_{\epsilon_q}(L_q)$ . Aqu6 as aplicaci3ns  $F_q : L_q \times [0, \epsilon_q) \rightarrow [0, \epsilon_q)$  e  $G_q : L_q \times [0, \epsilon_q) \rightarrow L_q$  son  $C^\infty$ .

Dirase que:

- un punto  $q \in \text{Fix}(\psi) \cap M$  6 simple se  $\det(1 - T_q\psi) \neq 0$ .

- un punto  $q \in \text{Fix}(\psi) \cap \text{sing}(A)$  é simple se para todo  $x \in L_q$  tense que  $F_q(0, x) \neq 1$  ou  $G_q(0, x) \neq x$ .

As condicións impostas na definición anterior implican que os puntos fixos simples son illados no conxunto  $\text{Fix}(\psi)$  (véxase unha explicación do caso singular en [9, § 3]).

Asumiranse as seguintes hipóteses relativas a  $\psi$ :

- O morfismo  $\psi$  fixa todo punto singular de  $A$ .
- O conxunto  $\text{Fix}(\psi)$  contén unicamente puntos fixos simples.
- Para todo  $q \in \text{sing}(A)$ , as aplicacións  $F_q$  e  $G_q$  son independentes de  $\rho$  arredor de  $q$ .

En particular, a hipótese (a) implica que  $\psi$  conserva as partes regular e singular de  $A$ . Logo en toda carta cónica  $O_q \equiv c_{\epsilon_q}(L_q)$  cúmprese  $F_q(\rho, x) > 0$  para todo  $\rho > 0$ . Debido a (1.5.1), a hipótese (c) significa que

$$\psi(\rho, x) = (\rho F_q(x), G_q(x))$$

en toda carta cónica  $O_q \equiv c_{\epsilon_q}(L_q)$  suficientemente pequena.

A métrica adaptada  $g|_{O_q}$  é cuasi-isométrica á métrica  $\rho^{2u} \tilde{g}_q + (d\rho)^2$  na variedade  $L_q \times (0, \epsilon_q)$ , sendo  $\tilde{g}_q$  métrica riemanniana en  $L_q$  e  $0 < u \leq 1$ . Defínese o número de Lefschetz máximo/mínimo asociado ao morfismo  $\psi$  como

$$L_{\max/\min}(\psi) = \sum_{r=0}^n (-1)^r \text{tr}(\psi^* \text{ on } H_{\max/\min}^r(M)).$$

## 6 Teoremas principais

Os resultados enunciados nesta sección e na seguinte foron publicados en [7], coa excepción daqueles referentes á fórmula da traza de Lefschetz.

O que segue é o primeiro dos teoremas relevantes desta tese, no cal a propiedade (ii) é unha versión débil da fórmula asintótica de Weyl.

**Teorema 1.6.1.** *As seguintes propiedades cúmprense para calquera estrato dunha estratificación compacta cunha boa métrica adaptada xeral:*

- $\Delta_{\max/\min}$  ten espectro discreto,  $0 \leq \lambda_{\max/\min,0} \leq \lambda_{\max/\min,1} \leq \dots$ , onde cada autovalor se repite conforme á súa multiplicidade.
- $\liminf_k \lambda_{\max/\min,k} k^{-\theta} > 0$  para algún  $\theta > 0$ .

O segundo teorema principal da tese é a seguinte versión das desigualdades de Morse para funcións de rel-Morse.

**Teorema 1.6.2.** *Para calquera función de rel-Morse nun estrato de dimensión  $n$  dunha estratificación compacta equipada cunha boa métrica adaptada xeral cúmprese que*

$$\sum_{r=0}^k (-1)^{k-r} \beta_{\max/\min}^r \leq \sum_{r=0}^k (-1)^{k-r} \nu_{\max/\min}^r \quad (0 \leq k < n),$$

$$\chi_{\max/\min} = \sum_{r=0}^n (-1)^r \nu_{\max/\min}^r.$$

O terceiro dos teoremas principais da tese é a seguinte versión da fórmula da traza de Lefschetz para espazos estratificados con singularidades illadas.

**Teorema 1.6.3.** *Considérese unha estratificación compacta orientable  $A$  con singularidades illadas e equipada cunha boa métrica adaptada no seu estrato regular  $M$ . Entón, para todo morfismo  $\psi : A \rightarrow A$  verificando as hipóteses (a)–(c), satisfáise que*

$$L_{\max/\min}(\psi) = \sum_{q \in \text{Fix}(\psi) \cap M} \text{sign det}(1 - T_q \psi) + \sum_{q \in \text{sing}(A)} L(G_q).$$

Nótese que  $L_{\max/\min}(\psi)$  non depende da elección (máxima ou mínima) da condición de fronteira ideal.

No caso concreto de métricas adaptadas de tipo cónico, os seguintes resultados xa foran obtidos con anterioridade:

- O teorema 1.6.1-(i) é esencialmente debido a Cheeger [18, 19] (véxase tamén [1, 2, 5]).
- O teorema 1.6.1-(ii) foi demostrado por Álvarez López e Calaza [5].
- O teorema 1.6.2 foi demostrado por Álvarez López e Calaza [5], e tamén por Ludwig [48] (con condicións máis restritivas pero consecuencias máis fortes).
- Unha versión do teorema 1.6.3 foi probada por Francesco Bei [9] (con condicións máis restritivas).

Outros desenvolvementos da teoría elíptica en estratos foron levados a cabo por diferentes autores [1, 2, 16, 23, 40, 42, 65], empregando todos eles métricas adaptadas de tipo cónico. A principal novidade desta tese é a extensión da teoría elíptica en estratos á máis ampla clase das boas métricas adaptadas xerais, o cal inclúe ás boas métricas adaptadas.

## 7 Aplicacións a homoloxía intersección

Considérese nesta sección o caso en que  $A$  é unha pseudovarietade estratificada con estrato regular  $M$ . Denótase por  $I^{\bar{p}}H_*(A)$  á homoloxía intersección de perversidade  $\bar{p}$  [32, 33] con coeficientes reais. Sexan  $\beta_r^{\bar{p}} = \beta_r^{\bar{p}}(A)$  e  $\chi^{\bar{p}} = \chi^{\bar{p}}(A)$  as versións dos números de Betti e da característica de Euler para  $I^{\bar{p}}H_*(A)$ . Toda perversidade pode ser interpretada como unha sucesión  $\bar{p} = (p_2, p_3, \dots)$  en  $\mathbb{N}$  satisfacendo que  $p_2 = 0$  e  $p_k \leq p_{k+1} \leq p_k + 1$ . Por exemplo, a perversidade cero é  $\bar{0} = (0, 0, \dots)$ , a perversidade total é  $\bar{t} = (0, 1, 2, \dots)$  ( $t_k = k - 2$ ), a perversidade intermedia inferior é  $\bar{m} = (0, 0, 1, 1, 2, 2, 3, \dots)$  ( $m_k = \lfloor \frac{k}{2} \rfloor - 1$ ), e a perversidade intermedia superior é  $\bar{n} = (0, 1, 1, 2, 2, 3, 3, \dots)$  ( $n_k = \lceil \frac{k}{2} \rceil - 1$ ). Ademais dúas perversidades  $\bar{p}$  e  $\bar{q}$  dinse complementarias se cumpren  $\bar{p} + \bar{q} = \bar{t}$ . Escribirase  $\bar{p} \leq \bar{q}$  cando  $p_k \leq q_k$  para todo  $k$ . Sexa  $g$  unha métrica adaptada en  $M$  de tipo  $\hat{u} = (u_2, \dots, u_n)$ . Se  $\hat{u}$  está asociada a unha perversidade  $\bar{p} \leq \bar{m}$  segundo

$$\left. \begin{aligned} \frac{1}{k-1-2p_k} \leq u_k < \frac{1}{k-3-2p_k} & \text{ if } 2p_k \leq k-3, \\ 1 \leq u_k < \infty & \text{ if } 2p_k = k-2, \end{aligned} \right\} \quad (1.7.1)$$

sucede que (véxase [13, 53, 54])

$$I^{\bar{p}}H_r(A)^* \cong H_{(2)}^r(M) \cong H_{\max}^r(M),$$

e, polo tanto,  $\beta_r^{\bar{p}} = \beta_{\max}^r$ . En particular,  $H_{(2)}^r(M) \cong I^{\bar{m}}H_r(A)^*$  se  $g$  é unha métrica adaptada de tipo cónico [20]. Logo a incompatibilidade dos produtos coas métricas adaptadas está relacionada coas sutilezas das versións do teorema de Künneth para homoloxía intersección [22, 29]. De feito, para pseudovarietades arbitrarias  $P$  e  $Q$ , o isomorfismo  $I^{\bar{p}}H_*(P \times Q) \cong I^{\bar{p}}H_*(P) \otimes I^{\bar{p}}H_*(Q)$  unicamente se ten para certas perversidades especiais, incluíndo  $\bar{p} = \bar{m}$ . De acordo con (1.7.1), existen boas métricas adaptadas en  $M$  con tipo asociado a calquera perversidade  $\leq \bar{m}$ .

En (1.7.1) tan só as eleccións  $2p_k = k - 2, k - 4, \dots$  son posibles se  $k$  é par, mentres que só as eleccións  $2p_k = k - 3, k - 5, \dots$  son posibles se  $k$  é impar. Consecuentemente, para todo  $k$ , (1.7.1) dá unha bixección entre as posibilidades para  $p_k$  e os elementos dunha partición de  $[\frac{1}{k-1}, \infty)$  en intervalos semiabertos, nos cales se toma  $u_k$ .

Sexa  $f$  unha función de rel-Morse en  $M$ . Dado  $x \in \text{Crit}_{\text{rel}}(f)$ , sexa  $X$  o estrato de  $\widehat{M}$  contendo a  $x$ , con  $k = \text{codim } X$ . Para calquera carta  $O \equiv O'$  de  $\widehat{M}$  centrada en  $x$  existe unha métrica adaptada  $\tilde{g}$  en  $N$  tal que en dita carta  $g|_O$  é cuasi-isométrica á restrición de  $g_0 + \rho_X^{2u_k} \tilde{g} + (d\rho_X)^2$  a  $M' \cap O'$ . Entón o tipo de  $\tilde{g}$  está tamén asociado a  $\bar{p}$ . Ademais haberá unha expresión  $m_X = m_+ + m_-$  ( $m_{\pm} \in \mathbb{N}$ ) e unha descomposición  $c(L_X) \equiv c(L_+) \times c(L_-)$  tales que  $M' \equiv \mathbb{R}^{m_+} \times N_+ \times \mathbb{R}_+ \times \mathbb{R}^{m_-} \times N_- \times \mathbb{R}_+$ ,

sendo  $N_{\pm}$  estrato denso de  $L_{\pm}$  e  $f|_O \equiv f(x) + \frac{1}{2}(\rho_+^2 - \rho_-^2)|_O$ , con  $\rho_{\pm}$  como función radial de  $\mathbb{R}^{m_{\pm}} \times c(L_{\pm})$ . Sexa  $k_{\pm} = \dim N_{\pm} + 1$ , de onde  $k = k_+ + k_-$ . Aquí as estratificacións  $L_{\pm}$  poden ser baleiras ou non, dando lugar a catro posibilidades. De feito,  $L_+ \neq \emptyset \neq L_-$  só poderá suceder se  $u_k = 1$  (sección 3). A partir de (1.4.1) e (1.4.2) séguese que os números  $\nu_{x,\max}^r$  son independentes da escolla de  $\hat{u}$  asociada a  $\bar{p}$ , polo que se utilizará a notación  $\nu_{x,r}^{\bar{p}} = \nu_{x,r}^{\bar{p}}(f)$ . Finalmente, defínese  $\nu_r^{\bar{p}} = \nu_r^{\bar{p}}(f) = \sum_x \nu_{x,r}^{\bar{p}} (x \in \text{Crit}_{\text{rel}}(f))$ , que coincide con  $\nu_{\max}^r$ .

Supóñase agora que  $A$  é orientable ( $M$  é orientable) e compacta. Tense que  $\beta_{\min}^r = \beta_{\max}^{n-r}$  para todo  $r$ , porque  $\Delta_{\min}$  se corresponde con  $\Delta_{\max}$  mediante o operador estrela de Hodge. Por outra banda, para calquera perversidade  $\bar{q} \geq \bar{n}$ , se  $\bar{p} \leq \bar{m}$  é complementaria de  $\bar{q}$ , satisfaise que  $I^{\bar{q}}H_r(A) \cong I^{\bar{p}}H_{n-r}(A)^*$  [32, 33]. Polo tanto, cúmprese  $\beta_r^{\bar{q}} = \beta_{n-r}^{\bar{p}}$ , concluíndose que  $\beta_r^{\bar{q}} = \beta_{\min}^r$ . Ao igual ca antes, a partir de (1.4.1) e (1.4.2) séguese que os números  $\nu_{x,\min}^r$  son independentes da escolla de  $\hat{u}$  asociada a  $\bar{p}$ . Emprégase entón a notación  $\nu_{x,r}^{\bar{q}} = \nu_{x,r}^{\bar{q}}(f) = \nu_{x,\min}^r$ , análoga á do caso máximo. En concordancia, defínese  $\nu_r^{\bar{q}} = \nu_r^{\bar{q}}(f) = \sum_x \nu_{x,r}^{\bar{q}} (x \in \text{Crit}_{\text{rel}}(f))$ , que coincide con  $\nu_{\min}^r$ .

O teorema 1.6.2 ten a seguinte consecuencia directa.

**Corolario 1.7.1.** *Sexan  $A$  unha pseudovarietade compacta de dimensión  $n$ ,  $M$  o seu estrato regular e  $\bar{p}$  unha perversidade. Se  $\bar{p} \leq \bar{m}$ , ou se  $A$  é orientable e  $\bar{p} \geq \bar{n}$ , entón, para calquera función de rel-Morse en  $M$  (con respecto a calquera boa métrica adaptada), satisfaise que*

$$\sum_{r=0}^k (-1)^{k-r} \beta_r^{\bar{p}} \leq \sum_{r=0}^k (-1)^{k-r} \nu_r^{\bar{p}} \quad (0 \leq k < n),$$

$$\chi^{\bar{p}} = \sum_{r=0}^n (-1)^r \nu_r^{\bar{p}}.$$

A teoría de Morse estratificada foi introducida por Goresky e MacPherson [35] e ten unha gran cantidade de aplicacións. En particular, Goresky e MacPherson probaron as desigualdades de Morse en variedades complexas analíticas con estratificacións de Whitney, considerando a homoloxía intersección con perversidade  $\bar{m}$  [35, capítulo 6, sección 6.12]. Ludwig tamén aportou unha interpretación analítica da teoría de Morse no sentido de Goresky e MacPherson para variedades conformalmente cónicas [44–47]. A versión presentada nesta tese para as funcións de Morse, os puntos críticos e os tipos asociados ás perversidades é diferente da empregada en [35], incluso para o caso da perversidade  $\bar{m}$ . Ata onde o autor coñece, o corolario 1.7.1 é a primeira versión das desigualdades de Morse para homoloxía intersección con perversidade  $\neq \bar{m}$ .

Considérese agora a notación da sección 5. O número de intersección de Lefschetz dun morfismo  $\psi$  con respecto á perversidade  $\bar{p}$  defínese [34] como

$$I^{\bar{p}}L(\psi) = \sum_{r=0}^n (-1)^r \operatorname{tr}(\psi^* \text{ on } I^{\bar{p}}H_r(A)^*).$$

O teorema 1.6.3 ten a seguinte consecuencia directa.

**Corolario 1.7.2.** *Sexa  $A$  unha pseudovariedade compacta orientable de dimensión  $n$  con singularidades illadas e estrato regular  $M$ . Sexa  $\bar{p}$  unha perversidade. Se  $\bar{p} \leq \bar{m}$  ou  $\bar{p} \geq \bar{n}$ , entón, para calquera morfismo  $\psi : A \rightarrow A$  cumprindo as hipóteses (a)–(c), satisfáise que*

$$I^{\bar{p}}L(\psi) = \sum_{q \in \operatorname{Fix}(\psi) \cap M} \operatorname{sign} \det(1 - T_q \psi) + \sum_{q \in \operatorname{sing}(A)} L(G_q).$$

## 8 Ideas principais das demostracións

Na demostración dos teoremas 1.6.1 e 1.6.2 varios pasos son coma no caso de métricas adaptadas de tipo cónico [5]. Nesta tese tan só se dan breves indicacións de tales pasos, mentres que aquelas partes con ideas novidosas son explicadas con detalle. Preséntase unha adaptación do coñecido método de Witten [70], seguindo principalmente o descrito en [59, capítulos 9 e 14]. Así, dada unha función de rel-Morse  $f$  en  $M$ , considerarase a perturbación de Witten  $d_s = e^{-sf} de^{sf} = d + s df \wedge$  en  $\Omega_0(M)$  ( $s > 0$ ). Denotarase por  $d_{s,\max/\min}$  á súa i.b.c máxima/mínima, con laplaciano correspondente  $\Delta_{s,\max/\min}$ . Posto que  $\Delta_{s,\max/\min} - \Delta_{\max/\min}$  é acotado, bastará con probar as propiedades do teorema 1.6.1 para  $\Delta_{s,\max/\min}$ . Ademais, usando un certo procedemento de globalización e unha versión do teorema de Künneth, será suficiente con considerar o caso dun estrato  $M = N \times \mathbb{R}_+$  do cono  $c(L)$  (estratificación non compacta), tomando unha boa métrica adaptada xeral da forma  $g = \rho^{2u} \tilde{g} + d\rho^2$  e a función de rel-Morse  $\pm \frac{1}{2} \rho^2$ , onde  $\rho$  é a función radial e  $L$  unha estratificación compacta de menor profundidade. Engadirase un til a aquela notación referente a conceptos relativos a  $N$ . Por indución na profundidade asúmese que  $\tilde{\Delta}_{\max/\min}$  verifica as propiedades do teorema 1.6.1. Entón as súas autoformas úsanse coma en [5] para escindir  $d_{s,\max/\min}$  en suma directa de complexos de Hilbert de lonxitudes un e dous, os cales quedan descritos mediante as i.b.c máximas/mínimas de certos complexos elípticos en  $\mathbb{R}_+$ . Os complexos elípticos de lonxitude un son do mesmo tipo cós de [5], polo que o laplaciano da súa i.b.c máxima/mínima é inducido a través do oscilador harmónico de Dunkl en  $\mathbb{R}$  [4], cuio espectro é ben coñecido. Sen embargo,

o laplaciano dos complexos elípticos de lonxitude dous é unha perturbación do oscilador harmónico de Dunkl que ten novos termos da forma  $\rho^{-2u}$  e  $\rho^{-2u-1}$ . Logo será preciso empregar unha ferramenta analítica distinta, que se trata na sección 10. Precisamente, na sección 10 faise uso de métodos clásicos de perturbación para determinar certos operadores autoadxuntos con espectro discreto definidos por tal perturbación do oscilador harmónico de Dunkl. A maiores, proporciónanse cotas superiores e inferiores para os seus autovalores. A aplicación desta técnica analítica é o que obriga a que a métrica adaptada xeral  $g$  sexa boa. A información obtida para esta perturbación é máis débil cá que se ten para o oscilador harmónico de Dunkl. Concretamente, a existencia de tales operadores só se pode garantir nalgúns casos, e unicamente se coñece un core do seu operador raíz cadrada. Deste modo, precisarase máis traballo ca en [5] para describir, empregando ditos operadores autoadxuntos, os laplacianos das i.b.c máximas/mínimas dos complexos elípticos simples de lonxitude dous. A demostración do teorema 1.6.1 complétase con esa información, da mesma maneira que en [5]. Por outra parte, para os autovalores destes operadores autoadxuntos só se teñen estimacións, feito que dificulta enormemente o cálculo da “contribución cohomolóxica” dos puntos rel-críticos. Esta é a idea chave para concluír a proba do teorema 1.6.2 de xeito análogo ao de [5]. A demostración do teorema 1.6.3 baséase na fórmula clásica da traza de Lefschetz para aplicacións  $C^\infty$  en variedades compactas [59, teorema 10.12]. Isto proporciona a contribución nula dos puntos non fixos e unha expresión para a contribución dos puntos fixos regulares. Polo tanto, a novidade desta demostración consiste no uso das autoformas harmónicas obtidas a partir da escisión de  $d_{s,\max/\min}$  para de calcular a contribución dos puntos (fixos) singulares.

## 9 Problemas abiertos

Descoñécese ata o de agora se a condición de que  $g$  sexa boa pode ser eliminada. Dependerá de se os resultados da sección 10 seguen sendo certos con hipóteses máis débiles.

As aplicacións dos resultados desta tese poderían aumentar ao estender a presente versión das desigualdades de Morse ao contexto das funcións de “rel-Morse-Bott.” Os seus conxuntos de puntos rel-críticos serían entón unións finitas de substratificacións. Tamén se podería estender a fórmula da traza de Lefschetz ao contexto de estratificacións xerais, mais isto implicaría a obtención dun certo resultado de control para o núcleo do calor fóra da diagonal.

Ademais debería existir unha extensión do isomorfismo  $H_{(2)}^r(M) \cong I^{\bar{p}}H_r(A)^*$  ao caso de métricas adaptadas xerais con perversidades xerais [30]. Nesta dirección, foi probada en [63, 64] unha extensión do teorema de de Rham con perversidades xerais. O caso con perversidades clásicas xa fora considerado en [12, 17].

Tamén resulta natural tratar de continuar co seguinte programa, que xa está resolto para o caso de variedades pechadas. En primeiro lugar, habería que demostrar a existencia dun burato espectral da forma  $\sigma(\Delta_{s,\max/\min}) \cap (C_1 e^{-C_2 s}, C_3 s) = \emptyset$ , para algúns  $C_1, C_2, C_3 > 0$ . Isto permitiría definir un complexo  $(\mathcal{S}_{s,\max/\min}, d_s)$  de dimensión finita xerado polas autoformas asociadas aos autovalores contidos no intervalo  $[0, C_1 e^{-C_2 s}]$  (“autovalores pequenos”). Posteriormente habería que probar que  $(\mathcal{S}_{s,\max/\min}, d_s)$  “converxe” ao complexo de “rel-Morse-Thom-Smale,” asumindo que a función satisfai a condición de transversalidade de “rel-Morse-Smale.” Semella que se pode obter con facilidade a existencia de tal burato espectral adaptando os argumentos de globalización empregados A comparación de  $(\mathcal{S}_{s,\max/\min}, d_s)$  co complexo de “rel-Morse-Thom-Smale” esixiría técnicas adicionais, de acordo co caso de variedades pechadas [36], [11, sección 6]. Este programa foi desenvolvido por Ludwig nun caso especial [48].

## 10 Oscilador harmónico de Dunkl

Explicaranse a continuación as ferramentas analíticas empregadas para demostrar os principais teoremas desta tese (sección 6). Os resultados enunciados neste apartado foron publicados en [6].

O operador de Dunkl en  $\mathbb{R}^n$  foi introducido por Dunkl [24–26], dando lugar ao que actualmente se coñece como teoría de Dunkl [62]. Xoga un papel importante en Física e procesos estocásticos (ver e.g. [31, 61, 68]). En particular, o oscilador harmónico de Dunkl en  $\mathbb{R}^n$  foi estudado en [27, 55, 56, 60]. Nesta tese só consideraremos dito operador en  $\mathbb{R}$ , onde está univocamente determinado por un parámetro. Neste caso Yang xa introducira previamente unha conxugación do operador de Dunkl [71] (véxase tamén [57]).

Fíxase a continuación a notación que se usa en toda esta sección. Sexa  $\mathcal{S} = \mathcal{S}(\mathbb{R})$  o espazo de Schwartz en  $\mathbb{R}$ , coa súa topoloxía de Fréchet, o cal se descompón como suma directa dos subespazos de funcións pares e impares,  $\mathcal{S} = \mathcal{S}_{\text{ev}} \oplus \mathcal{S}_{\text{odd}}$ . A compoñente par/impar dunha función de  $\mathcal{S}$  denótase co subíndice ev/odd. Dado que  $\mathcal{S}_{\text{odd}} = x\mathcal{S}_{\text{ev}}$ , onde  $x$  é a coordenada estándar de  $\mathbb{R}$ , a función  $x^{-1}\phi \in \mathcal{S}_{\text{ev}}$  está definida para toda  $\phi \in \mathcal{S}_{\text{odd}}$ . Sexa  $L_\sigma^2 = L^2(\mathbb{R}, |x|^{2\sigma} dx)$  ( $\sigma \in \mathbb{R}$ ), cuido produto escalar e norma escríbense  $\langle \cdot, \cdot \rangle_\sigma$  e  $\| \cdot \|_\sigma$ , respectivamente. A anterior descomposición de  $\mathcal{S}$  exténdese a unha descomposición ortogonal  $L_\sigma^2 = L_{\sigma,\text{ev}}^2 \oplus L_{\sigma,\text{odd}}^2$ , debido a que a función  $|x|^{2\sigma}$  é par.  $\mathcal{S}$  é un subespazo denso de  $L_\sigma^2$  se  $\sigma > -\frac{1}{2}$ , e  $\mathcal{S}_{\text{odd}}$  é denso en  $L_{\tau,\text{odd}}^2$  se  $\tau > -\frac{3}{2}$ . Salvo que se indique o contrario, asumírase que  $\sigma > -\frac{1}{2}$  e  $\tau > -\frac{3}{2}$ . O dominio dun operador (densamente definido)  $P$  nun espazo de Hilbert denótase por  $D(P)$ . A clausura de  $P$ , en caso de existir, indícase mediante  $\bar{P}$ . O dominio dunha forma sesquilinear (densamente definida)  $p$  nun espazo de Hilbert

denótase por  $D(\mathfrak{p})$ , do mesmo xeito que a súa forma cuadrática. A clausura de  $\mathfrak{p}$ , en caso de existir, indícase mediante  $\bar{\mathfrak{p}}$ . Para calquera operador  $L_\sigma^2$  conservando a anterior descomposición, as restricións a  $L_{\sigma, \text{ev/odd}}^2$  distínguense co subíndice ev/odd. O operador de multiplicación por unha función continua  $h$  en  $L_\sigma^2$  denótase tamén por  $h$ . O oscilador harmónico é o operador  $H = -\frac{d^2}{dx^2} + s^2x^2$  ( $s > 0$ ) en  $L_0^2$ , con  $D(H) = \mathcal{S}$ .

O operador de Dunkl en  $\mathbb{R}$  é o operador  $T$  en  $L_\sigma^2$  con  $D(T) = \mathcal{S}$  que vén determinado por  $T = \frac{d}{dx}$  en  $\mathcal{S}_{\text{ev}}$  e  $T = \frac{d}{dx} + 2\sigma x^{-1}$  en  $\mathcal{S}_{\text{odd}}$ . O oscilador harmónico de Dunkl en  $\mathbb{R}$  é o operador  $J = -T^2 + s^2x^2$  en  $L_\sigma^2$  con  $D(J) = \mathcal{S}$ . Polo tanto,  $J$  conserva a descomposición de  $\mathcal{S}$ , sendo  $J_{\text{ev}} = H - 2\sigma x^{-1} \frac{d}{dx}$  e  $J_{\text{odd}} = H - 2\sigma \frac{d}{dx} x^{-1}$ . Engadirase o subíndice  $\sigma$  a  $J$  cando sexa necesario.  $J$  é esencialmente autoadxunto, e o espectro de  $\bar{J}$  é ben coñecido [60]; de feito,  $\bar{J} > 0$ . Incluso para  $\tau > -\frac{3}{2}$  o operador  $J_{\tau, \text{odd}}$  está definido en  $L_{\tau, \text{odd}}^2$  con  $D(J_{\tau, \text{odd}}) = \mathcal{S}_{\text{odd}}$ , por ser unha conxugación de  $J_{\tau+1, \text{ev}}$  por un operador unitario. Certos operadores da forma  $J + \xi x^{-2}$  ( $\xi \in \mathbb{R}$ ) son conxugados de  $J$  por potencias  $|x|^a$  ( $a \in \mathbb{R}$ ), polo que o seu estudo redúcese ao caso de  $J$  [4]. O seguinte teorema analiza unha perturbación diferente de  $J$ .

**Teorema 1.10.1.** *Sexan  $0 < u < 1$  e  $\xi > 0$ . Se  $\sigma > u - \frac{1}{2}$ , existirá un operador autoadxunto positivo  $\mathcal{U}$  en  $L_\sigma^2$  satisfacendo as propiedades seguintes:*

(i)  $\mathcal{S}$  é un core de  $\mathcal{U}^{1/2}$  e, para todo  $\phi, \psi \in \mathcal{S}$ ,

$$\langle \mathcal{U}^{1/2}\phi, \mathcal{U}^{1/2}\psi \rangle_\sigma = \langle J\phi, \psi \rangle_\sigma + \xi \langle |x|^{-u}\phi, |x|^{-u}\psi \rangle_\sigma. \quad (1.10.1)$$

(ii)  $\mathcal{U}$  ten espectro discreto. Sexan  $\lambda_0 \leq \lambda_1 \leq \dots$  os seus autovalores, repetidos conforme á súa multiplicidade. Existe un  $D = D(\sigma, u) > 0$  e, dado  $\epsilon > 0$ , existe un  $C = C(\epsilon, \sigma, u) > 0$  tales que, para todo  $k \in \mathbb{N}$ ,

$$\lambda_k \geq (2k + 1 + 2\sigma)s + \xi D s^u (k + 1)^{-u}, \quad (1.10.2)$$

$$\lambda_k \leq (2k + 1 + 2\sigma)(s + \xi \epsilon s^u) + \xi C s^u. \quad (1.10.3)$$

*Oservación 1.10.2.* A partir do teorema 1.10.1 dedúcese o seguinte:

- (i) O segundo sumando do membro dereito de (1.10.1) ten sentido porque  $|x|^{-u}\mathcal{S} \subset L_\sigma^2$ , posto que  $\sigma > u - \frac{1}{2}$ .
- (ii)  $\mathcal{U} = \bar{U}$ , sendo  $U = J + \xi|x|^{-2u}$  con  $D(U) = \bigcap_{m=0}^\infty D(U^m)$  (véxase [41, VI-§ 2.5]). Tamén se usará a notación máis explícita  $U_\sigma$  se é necesario.
- (iii) As restricións  $\mathcal{U}_{\text{ev/odd}}$  son autoadxuntas en  $L_{\sigma, \text{ev/odd}}^2$  e cumpren (1.10.1) para  $\phi, \psi \in \mathcal{S}_{\text{ev/odd}}$ . Tamén verifican as desigualdades (1.10.2) e (1.10.3) con  $k$  par/impar. De feito, se  $\tau > u - \frac{3}{2}$ ,  $\mathcal{U}_{\tau, \text{odd}}$  está ben definida e satisfai tales propiedades.

Para demostrar o teorema 1.10.1 tómasse a forma sesquilinear simétrica e definida positiva  $u$ , que vén dada polo membro dereito de (1.10.1). Emprégase a teoría de perturbación [41] para probar que  $u$  ten clausura  $\bar{u}$ , a cal induce ao operador autoadxunto  $\mathcal{U}$ , e para relacionar os espectros de  $\mathcal{U}$  e  $\bar{\mathcal{J}}$ . A maior parte do traballo adícase a verificar as condicións que permiten aplicar esa teoría, de maneira que se deducen (1.10.2) e (1.10.3). De feito, (1.10.2) e (1.10.3) son máis fortes ca unha estimación xeral dada por dita teoría de perturbación.

Dados  $\sigma > -\frac{1}{2}$  e  $\tau > -\frac{3}{2}$ , sexa  $L_{\sigma,\tau}^2 = L_{\sigma,\text{ev}}^2 \oplus L_{\tau,\text{odd}}^2$ , cuio produto escalar e norma escríbense  $\langle \cdot, \cdot \rangle_{\sigma,\tau}$  e  $\| \cdot \|_{\sigma,\tau}$ , respectivamente. As expresións matriciais para operadores referiranse a esta descomposición. Sexa  $J_{\sigma,\tau} = J_{\sigma,\text{ev}} \oplus J_{\tau,\text{odd}}$  en  $L_{\sigma,\tau}^2$ , con  $D(J_{\sigma,\tau}) = \mathcal{S}$ . As hipóteses da seguinte xeneralización do teorema 1.10.1 cobren todos aqueles casos que se necesitan para o estudo dos complexos elípticos de lonxitude dous que se mencionan na sección 8.

**Teorema 1.10.3.** *Sexan  $\xi > 0$  e  $\eta \in \mathbb{R}$ . Tómanse*

$$0 < u < 1, \quad \sigma > u - \frac{1}{2}, \quad \tau > u - \frac{3}{2}, \quad \theta > -\frac{1}{2}, \quad (1.10.4)$$

e sexa  $v = \sigma + \tau - 2\theta$ . *Supóñase que se cumpren as condicións seguintes:*

(a) *Se  $\sigma = \theta \neq \tau$  e  $\tau - \sigma \notin -\mathbb{N}$ , tense que*

$$\sigma - 1 < \tau < \sigma + 1, 2\sigma + \frac{1}{2}. \quad (1.10.5)$$

(b) *Se  $\sigma \neq \theta = \tau$  e  $\sigma - \tau \notin -\mathbb{N}$ , tense que*

$$-\tau, \tau - 1 < \sigma < 3\tau + 1, 11\tau + 2, \tau + 1. \quad (1.10.6)$$

(c) *Se  $\sigma \neq \theta = \tau + 1$  e  $\sigma - \tau - 1 \notin -\mathbb{N}$ , tense que*

$$\tau + 1 < \sigma < \tau + 3, 2\tau + \frac{7}{2}. \quad (1.10.7)$$

(d) *Se  $\sigma \neq \theta \neq \tau$  e  $\sigma - \theta, \tau - \theta \notin -\mathbb{N}$ , tense que*

$$\left. \begin{aligned} \frac{\sigma - \tau}{2} - 1, \frac{\tau - \sigma}{2}, \frac{\sigma + \tau - 1}{4}, \frac{\sigma + 3\tau - 2}{14}, \frac{3\sigma + \tau - 4}{14}, \frac{\sigma + \tau - 1}{2} < \theta < \frac{\sigma + \tau + 1}{2}, \\ \tau - 1 < \sigma < \tau + 3. \end{aligned} \right\} \quad (1.10.8)$$

*Entón existirá un operador autoadxunto e definido positivo  $\mathcal{V}$  en  $L_{\sigma,\tau}^2$  satisfacendo as propiedades seguintes:*

(i)  *$\mathcal{S}$  é un core de  $\mathcal{V}^{1/2}$  e, para todo  $\phi, \psi \in \mathcal{S}$ ,*

$$\begin{aligned} \langle \mathcal{V}^{1/2}\phi, \mathcal{V}^{1/2}\psi \rangle_{\sigma,\tau} &= \langle J_{\sigma,\tau}\phi, \psi \rangle_{\sigma,\tau} + \xi \langle |x|^{-u}\phi, |x|^{-u}\psi \rangle_{\sigma,\tau} \\ &+ \eta (\langle x^{-1}\phi_{\text{odd}}, \psi_{\text{ev}} \rangle_{\theta} + \langle \phi_{\text{ev}}, x^{-1}\psi_{\text{odd}} \rangle_{\theta}). \end{aligned} \quad (1.10.9)$$

- (ii) Sexan  $\varsigma_k = \sigma$  se  $k$  é par, e  $\varsigma_k = \tau$  se  $k$  é impar.  $\mathcal{V}$  ten espectro discreto. Os seus autovalores forman dous grupos,  $\lambda_0 \leq \lambda_2 \leq \dots$  e  $\lambda_1 \leq \lambda_3 \leq \dots$ , repetidos conforme á súa multiplicidade. Existe un  $D = D(\sigma, \tau, u) > 0$  e, dado  $\epsilon > 0$ , existen  $C = C(\epsilon, \sigma, \tau, u) > 0$  e  $E = E(\epsilon, \sigma, \tau, \theta) > 0$  tales que, para todo  $k \in \mathbb{N}$ ,

$$\lambda_k \geq (2k + 1 + 2\varsigma_k) \left( s - 2|\eta| \epsilon s^{\frac{v+1}{2}} \right) + \xi D s^u (k+1)^{-u} - 2|\eta| E s^{\frac{v+1}{2}}, \quad (1.10.10)$$

$$\lambda_k \leq (2k + 1 + 2\varsigma_k) \left( s + \epsilon (\xi s^u + 2|\eta| s^{\frac{v+1}{2}}) \right) + \xi C s^u + 2|\eta| E s^{\frac{v+1}{2}}. \quad (1.10.11)$$

- (iii) Sexa  $\tilde{u} \in \mathbb{R}$  tal que

$$0, v, \tau - 2\theta + \frac{1}{2}, \sigma - 2\theta - \frac{1}{2} < \tilde{u} < 1, v + 1, \sigma + \frac{1}{2}, \tau + \frac{3}{2}, \quad (1.10.12)$$

e sexa  $\hat{u} = \max\{\tilde{u}, v + 1 - \tilde{u}\}$ . Existe un  $D = D(\sigma, \tau, u) > 0$  e, dado  $\epsilon > 0$ , existe un  $\tilde{C} = \tilde{C}(\epsilon, \sigma, \tau, u) > 0$  tal que, para todo  $k \in \mathbb{N}$ ,

$$\lambda_k \geq (2k + 1 + 2\varsigma_k) \left( s - |\eta| \epsilon s^{\hat{u}} \right) + \xi D s^u (k+1)^{-u} - |\eta| \tilde{C} s^{\hat{u}}. \quad (1.10.13)$$

- (iv) Se  $u = \frac{v+1}{2}$  e  $\xi \geq |\eta|$ , existe un  $\tilde{D} = \tilde{D}(\sigma, \tau, u) > 0$  tal que, para todo  $k \in \mathbb{N}$ ,

$$\lambda_k \geq (2k + 1 + 2\varsigma_k) s + (\xi - |\eta|) \tilde{D} s^u (k+1)^{-u}. \quad (1.10.14)$$

- (v) Engadindo o termo  $\xi' \langle \phi_{\text{ev}}, \psi_{\text{ev}} \rangle_\sigma + \xi'' \langle \phi_{\text{odd}}, \psi_{\text{odd}} \rangle_\tau$  na parte dereita de (1.10.9), con  $\xi', \xi'' \in \mathbb{R}$ , o resultado satisfaise igualmente ao poñer como termos adicionais  $\max\{\xi', \xi''\}$  na parte dereita de (1.10.11), e  $\xi'$  para  $k \in 2\mathbb{N}$  e  $\xi''$  para  $k \in 2\mathbb{N} + 1$  nas partes dereitas de (1.10.10), (1.10.13) e (1.10.14).

*Oservación 1.10.4.* A partir do teorema 1.10.3 dedúcese o seguinte:

- (i) Ao igual ca na observación 1.10.2-(ii), tense que  $\mathcal{V} = \overline{\mathcal{V}}$ , sendo

$$V = \begin{pmatrix} U_{\sigma, \text{ev}} & \eta |x|^{2(\theta-\sigma)} x^{-1} \\ \eta |x|^{2(\theta-\tau)} x^{-1} & U_{\tau, \text{odd}} \end{pmatrix},$$

con  $D(V) = \bigcap_{m=0}^{\infty} D(\mathcal{V}^m)$ . Nótese que o operador adxunto de  $|x|^{2(\theta-\sigma)} x^{-1} : \mathcal{S}_{\text{odd}} \rightarrow |x|^{2(\theta-\sigma)} \mathcal{S}_{\text{ev}}$ , como operador de  $L_{\tau, \text{odd}}^2$  a  $L_{\sigma, \text{ev}}^2$  densamente definido, vén dado por  $|x|^{2(\theta-\tau)} x^{-1}$ , considerado co dominio apropiado.

(ii) Tomemos  $\theta' = \theta - 1 > -\frac{3}{2}$ . Posto que

$$\langle x\phi, \psi \rangle_{\theta'} = \langle \phi, x^{-1}\psi \rangle_{\theta}$$

para todo  $\phi \in \mathcal{S}_{\text{ev}}$  e  $\psi \in \mathcal{S}_{\text{odd}}$ , pódese escribir (1.10.9) como

$$\begin{aligned} \langle \mathcal{V}^{1/2}\phi, \mathcal{V}^{1/2}\psi \rangle_{\sigma, \tau} &= \langle J_{\sigma, \tau}\phi, \psi \rangle_{\sigma, \tau} + \xi \langle |x|^{-u}\phi, |x|^{-u}\psi \rangle_{\sigma, \tau} \\ &\quad + \eta (\langle \phi_{\text{odd}}, x\psi_{\text{ev}} \rangle_{\theta'} + \langle x\phi_{\text{ev}}, \psi_{\text{odd}} \rangle_{\theta'}), \end{aligned}$$

para todo  $\phi, \psi \in \mathcal{S}$ , e, correspondentemente,

$$V = \begin{pmatrix} U_{\sigma, \text{ev}} & \eta |x|^{2(\theta' - \sigma)} x \\ \eta |x|^{2(\theta' - \tau)} x & U_{\tau, \text{odd}} \end{pmatrix}.$$

(iii) As condicións (1.10.5), (1.10.6) e (1.10.7) describen tres subconxuntos abertos convexos de  $\mathbb{R}^2$  (figura 1.10.1). A condición (1.10.8) describe un subconxunto aberto convexo de  $\mathbb{R}^3$  (figura 1.10.2), que é simétrico con respecto ao plano definido por  $\sigma = \tau + 1$ . Trátase dunha “barra semi-infinita” con 4 caras laterais e 5 lados no seu “final acotado.”

(iv) No teorema 1.10.3-(iii), a condición (1.10.12) significa que (1.10.4) se cumpre igualmente para  $\tilde{u}$  e  $v + 1 - \tilde{u}$  en lugar de  $u$ . Existe un  $\tilde{u}$  satisfacendo (1.10.12) só se

$$0, v, \tau - 2\theta + \frac{1}{2}, \sigma - 2\theta - \frac{1}{2} < 1, v + 1, \sigma + \frac{1}{2}, \tau + \frac{3}{2}. \quad (1.10.15)$$

Esta propiedade verifícase nos casos (b) e (d) debido a (1.10.4), (1.10.6) e (1.10.8); en particular, pódese tomar  $\tilde{u} = \frac{v+1}{2}$ . Para o caso (a), se  $\tau < 3\sigma$ , tense que (1.10.15) debido a (1.10.4) e (1.10.5). No caso (c), se  $\sigma < 3\tau + 4$ , tense que (1.10.15) debido a (1.10.4) e (1.10.7).



Figura 1.10.1: Conjuntos do teorema 1.10.3-(a),(b),(c).



Figura 1.10.2: Conjunto definido por (1.10.8) no teorema 1.10.3-(d).

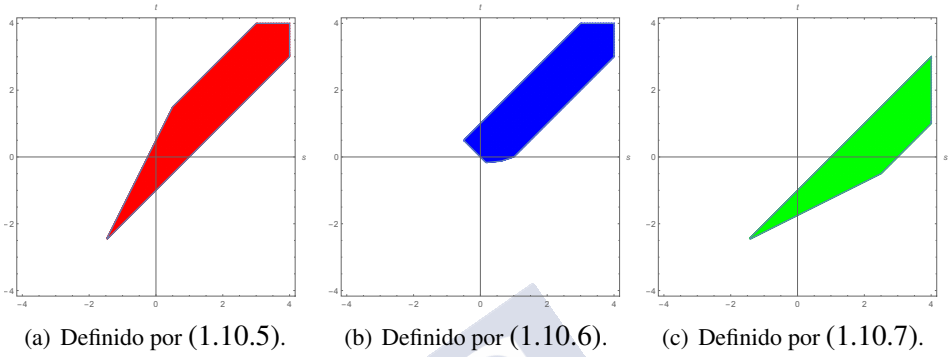

# Bibliography

---

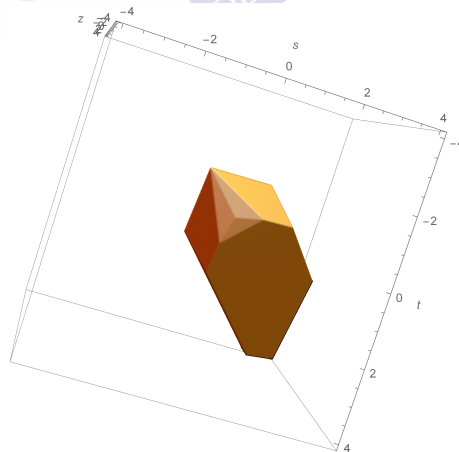
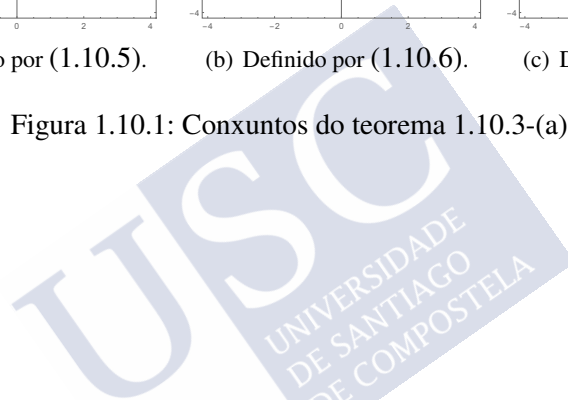
- [1] P. Albin, É. Leichtnam, R. Mazzeo, and P. Piazza, *The signature package on Witt spaces*, Ann. Sci. Éc. Norm. Supér. (4) **45** (2012), no. 2, 241–310.
- [2] P. Albin, É. Leichtnam, R. Mazzeo, and P. Piazza, *Hodge theory on Cheeger spaces*, J. Reine Angew. Math. **744** (2018), 29–102.
- [3] J.A. Álvarez López and M. Calaza, *Application of the method of Bonan-Clark to the generalized Hermite polynomials*, arXiv:1101.5022.
- [4] J.A. Álvarez López and M. Calaza, *Embedding theorems for the Dunkl harmonic oscillator*, SIGMA Symmetry Integrability Geom. Methods Appl. **10** (2014), 004, 16 pages.
- [5] J.A. Álvarez López and M. Calaza, *Witten’s perturbation on strata*, Asian J. Math. **21** (2017), 47–126.
- [6] J.A. Álvarez López, M. Calaza, and C. Franco, *A perturbation of the Dunkl harmonic oscillator on the line*, SIGMA Symmetry Integrability Geom. Methods Appl. **11** (2015), 059, 47 pages.
- [7] J.A. Álvarez López, M. Calaza, and C. Franco, *Witten’s perturbation on strata with general adapted metrics*, Ann.Glob.Anal.Geom. **54** (2018), no. 1, 25–69.
- [8] R. Askey and S. Wainger, *Mean convergence of expansions in Laguerre and Hermite series*, Amer. J. Math. **87** (1965), 695–708.
- [9] F. Bei, *The  $L^2$ -Atiyah-Bott-Lefschetz theorem on manifolds with conical singularities: a heat kernel approach*, Ann. Glob. Anal. Geom. **44** (2013), 565–605.
- [10] Bierstone, *Lifting isotopies from orbit spaces*, Topology **14** (1975), 245–252.

## BIBLIOGRAPHY

---

- [11] J.-M. Bismut and W. Zhang, *Milnor and Ray-Singer metrics on the equivariant determinant of a flat vector bundle*, *Geom. Funct. Anal.* **4** (1994), no. 2, 136–212.
- [12] J.P. Brasselet, G. Hector, and M. Saralegi, *Théorème de De Rham pour les variétés stratifiées*, *Ann. Global Anal. Geom.* **9** (1991), no. 3, 211–243.
- [13] J.P. Brasselet, G. Hector, and M. Saralegi,  *$L^2$ -cohomologie des espaces stratifiés*, *Manuscripta Math.* **76** (1992), 21–32.
- [14] G.E. Bredon, *Introduction to compact transformation groups*, Academic Press, New York-London, 1972.
- [15] J. Brüning and M. Lesch, *Hilbert complexes*, *J. Funct. Anal.* **108** (1992), no. 1, 88–132.
- [16] J. Brüning and M. Lesch, *Kähler-Hodge theory for conformal complex cones*, *Geom. Funct. Anal.* **3** (1993), no. 5, 439–473.
- [17] J.-L. Brylinski, *Equivariant intersection cohomology*, Kazhdan-Lusztig theory and related topics (Chicago, IL, 1989), *Contemp. Math.*, vol. 139, Amer. Math. Soc., Providence, RI, 1992, pp. 5–32.
- [18] J. Cheeger, *On the Hodge theory of Riemannian pseudomanifolds*, *Geometry of the Laplace operator* (Univ. Hawaii, Honolulu, Hawaii, 1979) (Providence, R.I.), *Proc. Sympos. Pure Math.*, vol. XXXVI, Amer. Math. Soc., 1980, pp. 91–146.
- [19] J. Cheeger, *Spectral geometry of singular Riemannian spaces*, *J. Differ. Geom.* **18** (1983), no. 4, 575–657.
- [20] J. Cheeger, M. Goresky, and R. MacPherson,  *$L^2$ -cohomology and intersection homology of singular varieties*, *Seminar on Differential Geometry* (Princeton, N.J.), *Ann. Math. Stud.*, vol. 102, Princeton University Press, 1982, pp. 302–340.
- [21] W.-S. Cheung, *Generalizations of Hölder's inequality*, *Int. J. Math. Math. Sci.* **26** (2001), 7–10.
- [22] D.C. Cohen, M. Goresky, and L. Ji, *On the Künneth formula for intersection cohomology*, *Trans. Amer. Math. Soc.* **333** (1992), no. 1, 63–69.

- [23] C. Debord, J.-M. Lescure, and V. Nistor, *Groupoids and an index theorem for conical pseudo-manifolds*, J. Reine Angew. Math. **628** (2009), 1–35.
- [24] C.F. Dunkl, *Reflection groups and orthogonal polynomials on the sphere*, Math. Z. **197** (1988), 33–60.
- [25] C.F. Dunkl, *Differential-difference operators associated to reflection groups*, Trans. Amer. Math. Soc. **311** (1989), 167–183.
- [26] C.F. Dunkl, *Integral kernels with reflection group invariants*, Canad. J. Math. **43** (1991), 1213–1227.
- [27] C.F. Dunkl, *Symmetric functions and  $B_N$ -invariant spherical harmonics*, J. Phys. A **35** (2002), 10391–10408.
- [28] A. Erdélyi, *Asymptotic forms for Laguerre polynomials*, J. Indian Math. Soc. **24** (1960), 235–250.
- [29] G. Friedman, *Intersection homology Künneth theorems*, Math. Ann. **343** (2009), no. 2, 371–395.
- [30] G. Friedman, *An introduction to intersection homology with general perversity functions*, Topology of stratified spaces, Math. Sci. Res. Inst. Publ., vol. 58, Cambridge Univ. Press, Cambridge, 2011, pp. 177–222.
- [31] V.X. Genest, L. Vinet, and A. Zhedanov, *The singular and the 2 : 1 anisotropic Dunkl oscillators in the plane*, J. Phys. A **46** (2013), 17
- [32] M. Goresky and R. MacPherson, *Intersection homology theory*, Topology **19** (1980), no. 2, 135–162.
- [33] M. Goresky and R. MacPherson, *Intersection homology II*, Inventiones Math. **71** (1983), no. 1, 77–129.
- [34] M. Goresky and R. MacPherson, *Lefschetz fixed point theorem for intersection homology*, Comment. Math. Helvetici **60** (1985), 366–391.
- [35] M. Goresky and R. MacPherson, *Stratified Morse theory*, Ergebnisse der Mathematik und ihrer Grenzgebiet, vol. 14, Springer-Verlag, Berlin, Heidelberg, New York, 1988.
- [36] B. Helffer and J. Sjöstrand, *Puits multiples en mécanique semi-classique. IV. étude du complexe de Witten*, Comm. Partial Differential Equations **10** (1985), no. 3, 245–340.

- [37] H. Hironaka, *Introduction to real-analytic sets and real-analytic maps*, Quaderni dei Gruppi di Ricerca Matematica del Consiglio Nazionale delle Ricerche, Istituto Matematico “L. Tonelli” dell’Università di Pisa, Pisa, 1973.
- [38] H. Hironaka, *Subanalytic sets*, Number theory, algebraic geometry and commutative algebra, in honor of Yasuo Akizuki (Tokyo), Kinokuniya, 1973, pp. 453–493.
- [39] H. Hironaka, *Stratification and flatness*, Real and complex singularities (Proc. Ninth Nordic Summer School/NAVF Sympos. Math., Oslo, 1976) (Alphen aan den Rijn), Sijthoff and Noordhoff, 1977, pp. 199–265.
- [40] E. Hunsicker and R. Mazzeo, *Harmonic forms on manifolds with edges*, Int. Math. Res. Not. **2005** (2005), no. 52, 3229–3272.
- [41] T. Kato, *Perturbation theory for linear operators*, Classics in Mathematics, Springer-Verlag, Berlin, 1995, Reprint of the 1980 edition.
- [42] M. Lesch, *Differential operators of Fuchs type, conical singularities, and asymptotic methods*, Teubner-Texte zur Mathematik, vol. 136, B.G. Teubner Verlagsgesellschaft mbH, Stuttgart, 1997.
- [43] S. Łojasiewicz, *Sur les ensembles semi-analytiques*, Actes du Congrès International des Mathématiciens (Nice, 1970), Tome 2 (Paris), Gauthier-Villars, 1971, pp. 237–241.
- [44] U. Ludwig, *The geometric complex for algebraic curves with cone-like singularities and admissible Morse functions*, Ann. Inst. Fourier (Grenoble) **60** (2010), no. 5, 1533–1560.
- [45] U. Ludwig, *A proof of stratified Morse inequalities for singular complex algebraic curves using Witten deformation*, Ann. Inst. Fourier **61** (2011), no. 5, 1749–1777.
- [46] U. Ludwig, *The Witten complex for singular spaces of dimension 2 with cone-like singularities*, Math. Nachrichten **284** (2011), no. 5-6, 717–738.
- [47] U. Ludwig, *The Witten deformation for even dimensional conformally conic manifolds*, Trans. Amer. Math. Soc. **365** (2013), no. 2, 885–909.
- [48] U. Ludwig, *Comparison between two complexes on a singular space*, J. Reine Angew. Math. **724** (2017), 1–52.

- 
- [49] J.N. Mather, *Notes on topological stability*, Mimeographed Notes, Harvard University, 1970.
- [50] J.N. Mather, *Stratifications and mappings*, Dynamical systems (Proc. Sympos., Univ. Bahia, Salvador, 1971), Academic Press, 1973, pp. 195–232.
- [51] B. Muckenhoupt, *Asymptotic forms for Laguerre polynomials*, Proc. Amer. Math. Soc. **24** (1970), 288–292.
- [52] B. Muckenhoupt, *Mean convergence of Laguerre and Hermite series. II*, Trans. Amer. Math. Soc. **147** (1970), 433–460.
- [53] N. Nagase,  *$L^2$ -cohomology and intersection cohomology of stratified spaces*, Duke Math. J. **50** (1983), 329–368.
- [54] N. Nagase, *Sheaf theoretic  $L^2$ -cohomology*, Adv. Stud. Pure Math. **8** (1986), 273–279.
- [55] A. Nowak and K. Stempak, *Imaginary powers of the Dunkl harmonic oscillator*, SIGMA Symmetry Integrability Geom. Methods Appl. **5** (2009), paper 016, 12 pp.
- [56] A. Nowak and K. Stempak, *Riesz transforms for the Dunkl harmonic oscillator*, Math. Z. **262** (2009), 539–556.
- [57] M. Plyushchay, *Hidden nonlinear supersymmetries in pure parabosonic systems*, Int. J. Mod. Phys. A **15** (2000), 3679–3698.
- [58] M. Reed and B. Simon, *Methods of modern mathematical physics IV: Analysis of operators*, Academic Press, New York, 1978.
- [59] J. Roe, *Elliptic operators, topology and asymptotic methods*, second ed., Pitman Research Notes in Mathematics, vol. 395, Longman, Harlow, 1998.
- [60] M. Rosenblum, *Generalized Hermite polynomials and the Bose-like oscillator calculus*, Nonselfadjoint operators and related topics (Beer Sheva, 1992) (Basel) (A. Feintuch and I. Gohberg, eds.), Oper. Theory Adv. Appl., vol. 73, Birkhäuser, 1994, pp. 369–396.
- [61] M. Rösler, *Generalized Hermite polynomials and the heat equation for Dunkl operators*, Comm. Math. Phys. **192** (1998), 519–542.
-

## BIBLIOGRAPHY

---

- [62] M. Rösler, *Dunkl operators: Theory and applications*, Orthogonal polynomials and special functions (Leuven, 2002) (Berlin) (E. Koelink and W. Van Assche, eds.), Lecture Notes in Math., vol. 1817, Springer, 2003, pp. 93–135.
- [63] M. Saralegi, *Homological properties of stratified spaces*, Illinois J. Math. **38** (1994), no. 1, 47–70.
- [64] M. Saralegi, *de Rham intersection cohomology for general perversities*, Illinois J. Math. **49** (2005), no. 3, 737–758.
- [65] B.W. Schulze, *The iterative structure of corner operators*, arXiv:0905.0977.
- [66] G. Szegő, *Orthogonal polynomials*, fourth ed., Colloquium Publications, vol. 23, Amer. Math. Soc., Providence, RI, 1975.
- [67] R. Thom, *Ensembles et morphismes stratifiés*, Bull. Amer. Math. Soc. **75** (1969), 240–284.
- [68] J.F. van Diejen and L. Vinet (eds.), *Calogero-Moser-Sutherland models*, CRM Series in Mathematical Physics, New York, Springer-Verlag, 2000.
- [69] A. Verona, *Stratified mappings—structure and triangulability*, Lecture Notes in Math., vol. 1102, Springer-Verlag, Berlin, Heidelberg, New York, Tokyo, 1984.
- [70] E. Witten, *Supersymmetry and Morse theory*, J. Differ. Geom. **17** (1982), no. 4, 661–692.
- [71] L.M. Yang, *A note on the quantum rule of the harmonic oscillator*, Phys. Rev., II. Ser. **84** (1951), 788–790.
- [72] K. Yosida, *Functional analysis*, sixth ed., Grundlehren der Mathematischen Wissenschaften, vol. 123, Springer-Verlag, Berlin-Heidelberg-New York, 1980.