



INTERNATIONAL DOCTORAL
SCHOOL OF THE USC

SAHAR
NAWAF ALDEIFI

PhD Thesis

Some results and algorithms on
matroids, simplicial complexes
and Alexandroff spaces

Santiago de Compostela, 2022



FACULDADE DE MATEMÁTICAS

DOCTORAL THESIS

Some results and algorithms on
matroids, simplicial complexes and
Alexandroff spaces

SAHAR NAWAF ALDEIFI

INTERNATIONAL PHD SCHOOL OF THE UNIVERSITY OF SANTIAGO DE
COMPOSTELA
PHD PROGRAMME IN MATHEMATICS



SANTIAGO DE COMPOSTELA
YEAR 2022



FACULTADE DE MATEMÁTICAS

DECLARACIÓN DE LA AUTORA DE LA TESIS

Some results and algorithms on matroids, simplicial complexes and Alexandroff spaces

Doña: Sahar Nawaf Aldeifi

Presento mi tesis, siguiendo el procedimiento adecuado al Reglamento y declaro que:

1. La tesis abarca los resultados de la elaboración de mi trabajo.
2. De ser el caso, en la tesis se hace referencia a las colaboraciones que tuvo este trabajo.
3. Confirmo que la tesis no incurre en ningún tipo de plagio de otros autores ni de trabajos presentados por mí para la obtención de otros títulos.
4. La tesis es la versión definitiva presentada para su defensa y coincide la versión impresa con la presentada en formato electrónico.

Y me comprometo a presentar el Compromiso Documental de Supervisión en el caso que el original no esté depositado en la Escuela.



En Santiago de Compostela, 10 de April de 2022.

Fdo.: Sahar Nawaf Aldeifi.



FACULTADE DE MATEMÁTICAS

AUTORIZACIÓN DEL DIRECTOR/ TUTOR DE LA TESIS

**Some results and algorithms on matroids,
simplicial complexes and Alexandroff spaces**

D. Antonio Gómez Tato

INFORMA:

Que la presente tesis, se corresponde con el trabajo realizado por Doña: Sahar Nawaf Aldeifi, bajo mi dirección/tutorización, y autorizo su presentación, considerando que reúne los requisitos exigidos en el Reglamento de Estudios de Doctorado de la USC, y que como director de esta no incurre en las causas de abstención establecidas en la Ley 40/2015.

En Santiago de Compostela, April 10, 2022.



Fdo.: Antonio Gómez Tato

The results presented in this thesis were obtained thanks to the Erasmus Mundus scholarship during the first year, Action 2 program, Strand 1, Lot 2, PEACE, with project code 2012-2618/001-001-EMA2.



European Commission
**ERASMUS
MUNDUS**

Acknowledgments

I would like to express my special appreciation and thanks to my advisor, Prof. Antonio Gómez Tato , for the patient guidance, encouragement and advice he has provided throughout my time as his student. Also I would like to thank all the members of staff at Santiago de Compostela University, whose guided me during my PhD Journey.

A special thanks for Eng. Islam Taha for his support especially developing one of the Python codes in this thesis (Section 2.5).

First of all, I thank the God for his blessing and inspiration for me in this work and for allowing go ahead me through all the difficulties.thank you Allah, you are the only one who let me finish my degree.
To my messenger and prophet Muhammad blessings of Allah be upon him, who recommended me to seek knowledge.
To my country Palestine and the beauty of Jerusalem, freedom to you.
To the soul of the scientist Muhammad Al-Khwarizmi, the father of algebra and the founder of algorithms.
To my teachets whose encouraged me, Dr. Ahmed Salam, Hammad, Reem and to the soul of Othman.

To my parents Nawaf and Soad,
without your prayer this work would not have been ended.
To my children Horelien and Yahya,
without you this work would have been ended a long time ago.

To my siblings, Abd Allah, Mohamed, Omar, Israa, Shams and their families.
To my uncels and aunts.
To my friends, Fedaa, Alaa, (Tizy-Mona), Eman, Najwa, Bothina, Asmaa, Diana and everybody whose supported me.

Words can not express how grateful I am to all of you.

Contents

Arabic Summary	III
Abstract	IX
Objectives and hypotheses	XI
Methodology	XIII
The state of the art	XV
Summary of Chapters Contents	XIX
Conclusions	XXV
1. Preliminaries	1
1.1. Simplicial Complex and Simplicial Maps	2
1.2. Simplicial Maps	10
1.3. Homotopy and Contiguous	12
1.4. Chain Complex and Homology	17
2. Comparison between 3 collapse types	23
2.1. Collapse concepts	24
2.2. Strong Collapse and Homotopy	26
2.3. Strong collapse Algorithm	30
2.4. Edge Contraction	40
2.5. Edge collapse Algorithm	46



3. Matroid	65
3.1. Preliminaries	65
3.2. Edge collapse and Matroids	74
3.3. Algorithm: Partition of matroid's base	76
4. Preorder and P-dominated point	85
4.1. Alexandroff space and preorder preliminaries	86
4.2. P -domination definition	91
4.3. Relationship between P -collapse and B -collapse	98
4.4. Homotopic spaces and their core	106
4.5. Between topological spaces and simplicial complex	114
5. Directed graph and Directed cyclic graph	119
5.1. Preliminaries	119
5.2. Relationship between directed graphs and preorders	128
5.3. Adjacency matrix and algorithms	132
List of Listings	141
List of Figures	145
List of Tables	147
List of Algorithms	147
A. Resumo	151
A.1. Antecedentes	151
A.2. Obxectivos e hipóteses	154
A.3. Metodoloxía	155
A.4. Conclusiones	155
A.5. Resumo dos contidos por capítulos	155
Bibliografía	163

Arabic Summary

ملخص محتويات الفصول

في الفصل الأول سنقدم بعض المفاهيم التمهيديّة حول الهوموتوبي وتكافؤ الهوموتوبي.

سندرس هذين المفهومين على (بنية) مهمة تسمى (المركب المبسط) الذي يعرف بطريقتين:

أولاً: الطريقة الهندسية حيث يكون (المركب المبسط الهندسي) عبارة عن فضاء طوبولوجي تم إنشاؤه من خلال (الإلتصاق) حيث النقاط مع النقاط والأضلاع مع الأضلاع والمثلثات مع المثلثات وبالمثل مع نظيراتها ذات الأبعاد ن.

ثانياً: الطريقة المجردة التجميعية، ويسمى (المركب المبسط المجرد) وهي عائلة من مجموعة تسمى (المبسطات)، وتبقى العملية داخلية عند أخذ الأجزاء.

سندرس العلاقات بين كلا المفهومين الهندسي والمجرد وكيف يمكننا الانتقال من مفهوم إلى آخر. نتذكر أيضاً أن الدوال الخاصة المسماة (الدوال المبسطة) بين مركبين مبسطين تعطينا دوال مستمرة للمركبات المبسطة الهندسية المرتبطة بها. ومع ذلك، هناك صعوبة في نقل المفهوم الهندسي للهوموتوبي بالكامل إلى تركيبات مبسطة، ولكن هناك عدة طرق. سنرى العديد منها في هذه الأطروحة.

ضمن هذا الإطار، سوف نتذكر في هذا الفصل مفهوم صفوف تسمى (الإستمرارية) والتي تعطي شكلاً نموذجياً لمفهوم الهوموتوبي نستطيع أن نطبقه على المركبات المبسطة على مستوى الهندسة الحقيقية.

في الفصل الثاني، نذكر إستراتيجية أوجدها (J.H.C Whitehead) في عام 1938، وهي أول محاولة لتصنيف المركبات المبسطة في صفوف الهوموتوبي المتكافئة. كانت إستراتيجياته الشهيرة تهدف إلى تقليل وتبسيط المركبات المبسطة المحدودة من خلال سلسلة من إزالة نوع خاص من المبسطات والمسماة (الوجوه الحرة) للوصول إلى الحد الأدنى من المركب المبسط المسمى (النواة)، وهذه العملية تسمى التقليل.

يفترض أن المركبات المبسطة تنتمي إلى نفس الفئة المكافئة إذا كان لديها نوى متشابهة. لكن هذه المحاولة لم تنجح نظرًا لوجود العديد من النوى التابعة لنفس المركب المبسط وذلك يعتمد على خطوات إزالة الوجوه الحرة وللأسف هذه النوى ليست متشابهة جميعها.

في عام 2012، نجح Barmak و Miniam في تطبيق هذه الفكرة، لتقليل وتبسيط المركبات المبسطة المحدودة باستخدام إستراتيجية تسمى التقليل القوي. والتي سنناقشها في القسم 2.2. اعتمادا على إزالة (الرؤوس المراقبة) من قبل رؤوس اخرى.

تمت دراسة إستراتيجية ثالثة تسمى (تقليل الأضلاع) على الطوبولوجيا بواسطة Walkup في عام 1970. في هذا الفصل سنقارن بين الاستراتيجيات الثلاثة. في القسم 2.3 والقسم 2.5، سنذكر خوارزميتين لتقسيم المبسطات العظمى التي تغطي المركب المبسط إلى مركبات جزئية، حيث يمكن أن نقلص كل مركب جزئي تقليصا قويا إلى نقطة ما أو نقلصه تقليص أضلاع إلى نقطة ما.

عدد هذه المركبات الجزئية سيمثل الحد الأعلى لـ Gscat / Ecat على التوالي. تُظهر كل خوارزمية إستراتيجية مختلفة لتكوين التقليل القوي، وتم ترميز كل خوارزمية باستخدام برنامج بايثون، وكذلك تم تطبيق بعض الأمثلة الشهيرة للمركبات المبسطة على البرنامج وتوضيح عملية نقلصها للوصول إلى النواة.

الفصل الثالث مخصص لدراسة التركيبات المسماة (ماترويد). تذكر أن الماترويد تم تقديمها وتسميتها بواسطة H. Whitney في عام 1935 كتعميم مجرد للمصفوفات. ولكن ممكن تصورها على شكل مركب مبسط وبسيط للغاية من وجهة النظر الهomotوبية حيث أن هذه الماترويد تكافئ هموتوبيا مجموعة من الكرات الملتقبة، لكنها لا تزال مهمة من وجهة نظر "الهوتوبي الحسابي". نحن نثبت في هذا الفصل أن صفوف الماترويد لا تفقد خاصيتها عند حذف رأس أو نقلص ضلع.

نظرية رقم 3.1.5

كما نثبت ان الماترويد إما أن يكون نواه وذلك إذا كان تقاطع جميع المبسطات العظمى فارغا. اما إذا كان التقاطع يحتوي على نقطة واحدة على الأقل فإننا نستطيع تقليص هذا الماترويد إلى هذه النقطة وذلك سواء عن طريق التقليل العادي أو التقليل القوي.

في القسم 3.3. نظهر أن تقليص الأضلاع من الماترويد لا يؤثر على خصائصه ويولد ماترويد جديد. و نظهر أن النظرية السابقة غير صحيحة إذا طبقنا استراتيجية تقليص الأضلاع. ثم نطور خوارزمية لتقسيم المبسطات العظمى في الماترويد إلى مجموعات من الماترويدات الجزئية يمكن تقليص كل واحدة بقوة إلى نقطة. يتم أيضًا ترميز هذه الخوارزمية باستخدام برنامج بايثون.

الفصل الرابع هو أكبر فصول هذه الأطروحة وهو مخصص لدراسة قابلية تقليص فضاءات ألكسندروف الطوبولوجية الغير المحدودة. تسمى العلاقة الثنائية الانعكاسية والمتعدية (التسلسل). التسلسل يسمى مجموعة مرتبة جزئياً) إذا كانت هذه العلاقة لا تناظرية أيضاً.

فضاء الكسندروف هو فضاء طوبولوجي يكون فيه تقاطع أي مجموعة من المجموعات المفتوحة مفتوحاً أيضاً.

يمكننا توليد علاقة تسلسل إذا كان لدينا أي فضاء طوبولوجي. وإذا كان هذا الفضاء هو فضاء الكسندروف فإن علاقة التسلسل تسمى التسلسل المتخصص، وإذا كان هذا الفضاء T_0 فإن علاقة التسلسل تكون مجموعة مرتبة جزئياً. في الواقع، هناك تكافؤ بين طوبولوجيا التسلسل وطوبولوجيا الكسندروف.

يُظهر McCord أن لكل مجموعة مرتبة جزئياً، يمكن للمرء أن يربط مركب مبسطاً مجرداً يسمى (مبسط الترتيب). ولكل مركب مبسط، يمكن أن يربط بينه وبين مجموعة مرتبة جزئياً حيث تربط الإثنان علاقة تكافؤ هموتوبي ضعيف.

ذكر [35] Stong مفاهيم إزالة نقطة خاصة تسمى (نقاط الإيقاع) من الفضاء مع الاحتفاظ بنوعها المتمائل هموتوبيا، وقدم مفهوم (نوى) للفضاءات المحدودة.

ثم عمم May و Kukiela نتيجته على فضاءات الكسندروف غير محدودة. فقد قاموا بتقليص الفضاء من خلال سلسلة من الخطوات، في كل خطوة قاموا بإزالة نقطة إيقاع واحدة. نسمي هذه العملية بـ (تقليص أ). صنف Kukiela أيضاً صفوف فضاءات الكسندروف اللانهائية وبرهن نتائج تظهر أن بعض الفضاءات المحدودة محلياً يمكن أن تكون مكافئه هموتوبيا للنواة.

تعريف 4.2.2

في هذا التعريف سنقوم بتوسيع تعريف نقاط الإيقاع (حيث نقوم بإزالة نقطة واحدة في كل خطوة) إلى تعريف مفهوم جديد يسمى (النقاط المراقبة ب) حيث نستطيع في كل خطوة تقليص مجموعه خاصه قد تحتوي على نقاط غير محدودة وأسميناها (مجموعة الانكماش)، نسمي هذه الاستراتيجية (التقليص ب). الفضاء الخالي من النقاط المراقبة ب يسمى (النواة ب).

نظرية 4.2.9

قمنا ببرهنة أن تقليص مجموعة الانكماش لا يؤثر على الخصائص هموتوبية لفضاءات الكسندروف التوبولوجية سواء كانت محدودة او غير محدودة.

نظرية 4.3.5

في القسم 4.3، نناقش العلاقات بين نقاط الإيقاع والنقاط المراقبة من خلال نظريتنا الرئيسية التي توضح أن في فضاء الكسندروف تعطي كلا عمليتي تقليص أ أو تقليص ب نفس النتائج إذا كان الفضاء يحتوي على سلاسل محدودة فقط.

علاوة على ذلك نذكر المثال 4.3.5. الذي يظهر فضاء يحتوي على سلاسل لا نهائية حيث يمكننا إجراء تقليص ب للفضاء إلى نقطة ما ولكن لا يمكننا تقليص أ لبعض النقاط في هذا الفضاء.

في المثال 4.3.6. نظهر فضاء يمكننا تقليصه في كلا الاستراتيجيتين أ و ب إلى نقطة على الرغم من احتواء الفضاء على سلاسل لا نهائية. أخيراً في المثال 4.3.7. نظهر مساحة تحتوي على سلاسل لا نهائية ويمكننا إجراء تقليص ب إلى نقطة واحدة فقط. لكن هذا الفضاء لا يحتوي على أي نقاط إيقاع، لذلك لا يمكننا إجراء أي عملية تقليص من النوع أ له بأي شكل ممكن، أي ان الفضاء نواة من النوع أ.

ذكر Kukiela النظرية التالية 4.4.5.

إذا كان الفضاء عبارة عن نواة من النوع ج فلا توجد داله في الفضاء (X, X) مكافئه هموتوبيا مع داله الوحدة بخلاف داله الوحدة.

نذكر في التعريف 4.4.6. فضاء تسمى الفضاء المحدد، تحت هذا الفضاء يمكننا تعميم هذه النظرية. ثم نذكر نظرية 4.4.9. التي تعمل على تحسين وتعميم نظرية Kukiela، كما أننا نقدم البرهان بشكل أكثر بساطة.

في الفصل الخامس قدم Adamaszek Michal و Henry Adams تجريباً مجمعاً للريال من الرسوم البيانية تسمى الرسوم البيانية الدورية، كما أنهم عرفوا (الرأس المراقب السالب)، قمنا بتقديم تعريفاً مماثلاً يسمى (الرأس المراقب الموجب) وأثبتنا أنه إذا كان لدينا رسم بياني دوري، ثم:

يوجد رأس المراقب السالب فقط فقط إذا وجدنا رأس المراقب موجب وبالعكس.

علاوة على ذلك، فإن عدد الرؤوس المراقبة السالبة يساوي عدد الرؤوس المراقبة الموجبة. في القسم 5.2 درسنا العلاقة بين الرسوم البيانية الموجهة وفضاءات التسلسل.

في القسم 5.3، حددنا الخوارزميات لاكتشاف ما إذا كانت مصفوفة التقارب تمثل رسماً بيانياً دورياً، وإذا كان هذا صحيحاً، فكيف يمكننا تحديد الرؤوس المراقبة من خلال هذه المصفوفة أيضاً إذا كان بإمكاننا إعادة ترتيب أي مصفوفة لاكتشاف ما إذا كانت تمثل رسماً بيانياً دورياً ام لا.

Abstract

The notions of homotopy and the homotopy equivalence are the central concepts in Homotopy Theory. Unfortunately, given two spaces, it is very difficult to decide whether they are homotopic equivalents.

The approach to this problem through the use of combinatorial methods applied to the study of simplicial complexes began in the 1930s and 1940s and culminated (provisionally) in 1950 when JHC Whitehead introduced the idea of elementary collapse of CW spaces and the simple homotopy type.

In 2012 Barman and Minian return to the topic and develop the theory of strong collapse of simplicial complexes, which has interesting applications to collapsibility problems.

In this thesis we first review both concepts and a third one - edge collapse - and explore their consequences on matroids (a special kind of simplicial complexes). Secondly, we study a generalization of the idea of strong collapse to (non-finite) Alexandroff spaces. Finally, we present several algorithms to facilitate the exploration of all these concepts in the case of finite simplicial complexes and directed graphs.

Objectives and hypotheses

The notion of beat point introduced by Stong in the context of finite spaces can be generalized to Alexandroff spaces. So the principal objective of this thesis is:

To introduce and to study the new notion of dominated point in an Alexandroff space as a generalization of beat points.

Secondly, I have another three objectives:

- To prove several new results on matroids, simplicial complexes and Alexandroff spaces, most related with the notion of collapsibility.
- To design useful algorithms to make easier study of the collapsibility of a simplicial complex.
- To state some results and algorithms on directed graphs.

Methodology

In this thesis I followed the classic methodology in basic research in mathematics. Some standard tasks in this type of research are proposals for definitions, conjectures of results that generalize others already known, or which can be compared with them, and these arch for new examples that are significant enough or have important applications in other areas of mathematics. To do so, it is necessary to carry out a preliminary and comprehensive study of the topics to be addressed, and it is also very convenient to get in contact with experts of other universities. Finally, the use of computers to perform symbolic calculations was an essential tool in different parts of the thesis.

The state of the art

The notion of homotopy, homotopy equivalence and homotopy type are the central concepts in Homotopy Theory. Unfortunately, given two spaces it is very hard to decide whether they are or not homotopy equivalents.

In the 1930's and 1940's the approach to this problem was to use some kind of combinatorial methods applied to symbolic simplicial complex (now knew as abstrat simplicial complex). Following this approach and the formalism given by Alexander in his paper (1926, Combinatorial Analysis Situs.) Whitehead in 1938 (Simplicial Spaces, nuclei and m-Groups) started a serie of very important papers. In the first one he introduced the notion of elementary collapses and the nucleus of a simplicial complex and he culminated the serie in 1950 by introducing the notion of simple homotopy type of CW spaces (that he defined to scape from the technical problems he found working with simplicial complexes).

In our history, 1966 is a very special year, because two seminal papers were published. In the fist one, due to Stong (Finite Topological Spaces) it was highlighted that it worth to study the finite spaces from the topological point of view. In particular Stong remarked in his paper that given a finite topological space, X , every point $x \in X$ has a minimal open set U_x that contains it (the intersection of every open set containing x), this idea allowed him to introduce a partial order on X and he introduced the definition of linear and colinear points (now called beat points) as:

Definition (Stong 1966). *Lat F be a finite space.*

1. $x \in F$ is linear if $\exists y > x$ such that if $z > x$ then $z \geq y$
2. $x \in F$ is colinear if $\exists y < x$ such that if $z < x$ then $z \leq y$



Stong showed that the removal and inclusion of beat points generate all homotopy equivalences between (pointed) finite spaces. That is, two finite spaces are homotopy equivalent if and only if one can be obtained from another by successively removing or adding beat points.

The other 1966's paper that we are interested is due to McCord. In it, the author related finite topological spaces to finite simplicial complex in a functorial way. So he proved the following theorem

Theorem (McCord 1966). *(i) For each finite topological space X there exist a finite simplicial complex $K(X)$ and a weak homotopy equivalence $f : |K(X)| \rightarrow X$. (ii) For each finite simplicial complex K there exist a finite topological space X and a weak homotopy equivalence $f : |K(X)| \rightarrow X$.*

But, the main idea for the correspondences in the above theorem was already contained in the paper 1937 in the paper where P. S. Alexandroff, introduced the "Diskrete Raume"(discrete space), now knew as Alexandroff space (A -space), as a topological space were the arbitrary intersection of open sets is an open set. In particular, a finite topological space is an Alexandroff space. I worth remark that 1966 was the publication year of the Spanier's book "Algebraic topology"

In 2008 Barmak and Minian in his paper "simple homotopy type and finite spaces" merged the ideas of Whitehead, Stong and McCord and presented a new approach to simple homotopy theory of polyhedra using finite topological spaces and generalized the Stong's notion of beat point by introducing that they called weak beat points.

Definition (Definition 3.2 Barmak-Minian 2008). *Let X be a finite T_0 -space. We will say that $x \in X$ es a weak beat point of X (or a weak point for short) if either \hat{U}_x is contractible or \hat{F}_x is contractible. In the first case we say that x is down weak point and in the second, that x is an up weak point.*

where \hat{U}_x (\hat{F}_x) denotes the points of X greater (lower) than x when we considered in X the pre-order given by the topology.

This new concept allowed them to introduced the concept of collapse of a finite space and they proved that this new notion corresponds exactly to the concept of a simplicial collapse introduced by Whitehead. More precisely, they shown that a collapse $X \searrow Y$ of finite spaces induces a simplicial collapse

$K(X) \searrow K(Y)$ of their associated simplicial complexes. Moreover, also they proved that a simplicial collapse $K \searrow L$ induces a collapse $X(K) \searrow X(L)$ of the associated finite spaces. In this way they established a one-to-one correspondence between simple homotopy types of finite simplicial complexes and simple equivalence classes of finite spaces.

But with this very good idea of weak points we get, by using combinatorial methods, only a minimal part of the homotopy of the polyhedron when we think they as topological spaces, so a new combinatorial idea has to be found. We needn't to wait much time because in 2012 both authors (Minian and Barak) succeed to introduced the concept of strong collapse, a particular kind of simplicial collapse. The advantage of using strong collapses is the existence and uniqueness of cores (property that the cores introduced by Whitehead in 1938 doesn't have)

The principal purpose of my research is to understand these concepts and to improve it as much I can. But, computational topology is another source of interest in my research. Let me explain a little what is about.

It is obvious for any observer that the huge improvement of the technology (computers, sensors and communications) in the last decades, produced a big impact in mathematics. There are a lot of mathematicians working in data analysis, Machine learning and related techniques. Surprisingly (or not) this impact also reached something so abstract as algebraic topology. Since this century begun there is an increasing interest in Topological Data Analysis and Computational Topology. To use computers to study topological spaces or clouds of data with topological methods it is necessary to code them as a combinatorial object and it seems the simplicial complex is the best mathematical object for this. So we can associate to a cloud of points a simplicial complex and by using persistent homology coded the cloud of point as a barcode or a persistence diagram that allows to extract an interesting information from the data.

But a simplicial complex associated to the data could be huge and the computers hasn't enough power to deal with, so collapses as we describe in this thesis can be used to reduce the complexity of the problem.

Also, the computational techniques can help to understand a mathematical concept or to make examples or experimental mathematics, and in this sense I designed several algorithms to help the researches to study several properties of simplicial complex or graphs (a simplicial complex of dimension 1).

Summary of Chapters Contents

We will explain with a little details the contents in each chapter.

In the first chapter we introduce some preliminaries about homotopy and equivalence of homotopy. We study these two concepts over an interesting structure called *simplicial complex*. We study simplicial complex in two ways: firstly in a geometric way where a simplicial complex is a topological space constructed by 'gluing together" points, edges, triangles, and their n-dimensional counterparts and secondly in a combinatorial one, where the abstract simplicial complex which is a family of set, called simplices, that is closed under taking subsets. We will study the relations between both definitions and how we can pass from one to another. Also we will remember that spacial maps called *Simplicial maps* between two (combinatorial) simplicial complex give us continuous maps between the associated geometric simplicial complexes. However it is impossible to fully translate the geometric notion of homotopy into a combinatorics, but there are several approaches. We will see several of these in this thesis. In this sense, we will recall in this chapter the notion of *classes of contiguity* which gives a constructive form of homotopy applicable to simplistic applications at the level of geometric realizations.

In the second chapter, we recall a procedure invented by J. H. C. Whitehead in 1938, which is the first attempt to classify the simplicial complexes in equivalent homotopy classes. His famous strategies was to minimize and simplify finite simplicial complexes through a sequence of removing simplices called *free faces* to reach a minimal complex called *the core*, this operation called *The Collapse*, he assume that simplicial complexes belong to the same

equivalent class if they have an isomorphic cores. But this attempt did not success since there is many cores of the same complex depending on the steps of removing the free faces and those cores are not unique up to isomorphisms,

In 2012 Barmak and Miniam success to apply this idea, to minimize and simplify finite simplicial complexes using a strategy called *strong collapse* which we will discuss in Section 2.2. depending on removing a *dominated vertices*.

A third procedure called *edge collapse* was initially studied on topology by Walkup in 1970. In this chapter we will compare between the three types.

In Section 2.3 and Section 2.5, we will state two algorithms to partition the maximal simplices which covers the simplicial complex into subcomplexes, each subcomplex can strong collapse/edge collapse to a point. the number of these subcomplexs will be an upper bound of $Gscat/Ecat$. Each algorithm shows a different strategy to perform the strong collapse, And each algorithm is coded using Python program, some famouse examples are applied with the programs.

The third chapter is dedicated to study the constructions of matroids. Remember that matroids were introduced and named by H. Whitney in 1935 as an abstract generalization of matrices. its realization as simplicial complex is very simple from the homotopic point of view since they are homotopy equivalent to wedges of spheres, but it is still interesting from the 'combinatorial homotopic' point of view. We proof in this chapter that the class of matroid are closed under deletion a point or contracting an edge. Also we proof the following

Theorem. 3.1.3 *if we have an empty intersection of the maximals set of a matroid, then we can not strong collapse this matroid.*

Let $\mathcal{B}(M) = \{F_i : i \in \Delta\}$ be the base for a matroid M . If $\bigcap_{\mathcal{B}(M)} F_i = \phi$, then M has no dominated vertices, that's means M is a core.

Theorem 3.1.4.

Theorem. 3.1.5 *Let M be a matroid with the base $\mathcal{B}(M) = \{F_i : i \in \Delta\}$ such that $|F_i| = n$, and let e be a vertex in $V(M)$, then the following statement are equivalent:*



- a. $e \in \bigcap_{i \in \Delta} F_i$.
- b. $M \searrow \searrow \{e\}$ (i, e, M collapse to e).
- c. $M \searrow \{e\}$ (i, e, M strong collapse to e).
- d. There exist a free face.
- e. There exist a dominated vertices.

So we conclude that every matroid is either a core or it is strong collapsible to a point. In part d. for any maximum F_i , $(F_i, F_i \setminus e)$ generates a free face.

In Section 3.3 . we show that contracting an edge from a matroid yields to a new matroid. then we show that Theorem 3.1.4 is not true for edge contraction. Then we state an algorithm to partition the maximals of matroid into strongly collapsible submatroids.

Also this algorithm is coded using Python program.

Chapter four is the biggest one in this thesis and it is devoted to study collapsibility on non-finite Alexandroff spaces. A binary reflexive and transitive relation is called a *preorder*. A preorder is a *partial order set* or *poset* if it is also antisymmetric. Also an *Alexandroff topological space*, is a topology where the intersection of any family of open sets is open.

If we have any topological space, the inclusion gives a preorder relation over set of open sets. If this topology is Alexandroff space, the preorder defined is called *specialization preorder*, and if the topology is a T_0 space then its specialization preorder is a poset. Actually there is an equivalence between preorders and Alexandroff topologies. McCord shows to every poset , one can associate an abstract simplicial complex called *the order complex*. And to every simplicial complex, one can associate a poset that is weak homotopy equivalent to it.

Stong [35] state the concepts of removing special point called *beat points* from the space with keeping its homotopy type, he introduced the concept of *cores of finite spaces*, then May and Kukiela generalized his result into infinite Alexandroff space. they minimize the space through a sequence of steps, in

each step we remove a single beat point. we call this operation by *B-collapse*. Kukiela classified the class of infinite Alexandroff spaces and proved results showing that some locally finite spaces can be strong deformation retracted to a core.

Definition. 4.2.2 Let (X, \leq) an Alexandroff space and $a, b \in X$ such that $a \not\leq b$

1. We say that a is p^+ dominated by b , if $c \geq a$ implies $c \sim b$. In this case we will denote A_{ab}^+ the set $\{s \in X : a \leq s < b\}$.
2. We say that b is p^- dominated by a , if $c \leq b$ implies $c \sim a$. In this case we will denote A_{ab}^- the set $\{s \in X : a < s \leq b\}$.

A subset A of X is called a contraction set if there exist two points $a, b \in X$ such that a is p^+ dominated by b , hence $A = A_{ab}^+$ or b is p^- dominated by a , hence $A = A_{ab}^-$.

In this definition we will extend the definition of beat points (where we remove a single point in each step) to a new definition called p -dominated (where we can in one step remove from the space the contraction set (maybe infinite points)), we call this operation by *P-collapse*. The space with no P -dominated points called *P-core*.

Theorem. 4.2.9 Let (X, \leq) be an Alexandroff topological space, and suppose that a is p^+ dominated by b , with a contraction set A_{ab}^+ , then $X - A_{ab}^+$ is a strong deformation retract of X . Similarly, the retract generated from removing p^- dominated point and the retract generate from elementary P -expansion, both are strong deformation retracts also.

In Section 4.3, we discuss relations between up-beat/down-beat points and p^+/p^- -dominated points through our main theorem which shows that P -collapse and B -collapse operations are similar if the space contains only finite chains:

Theorem. 4.3.5 In Alexandroff space X . Every finite-chain contraction set A^+ can be represented by sequences of B^+ -collapses in at most ω steps, where ω is the first ordinal. Similarly, Every contraction set A^- can be represented by sequences of B^- -collapses removing down-beat points.

Moreover we state Example 4.3.5. to show a space contains infinite chains that we can P-collapse a space to a point but we can not B-collapse some points in this space. In Example 4.3.6. We show a space that we can P-collapse to a point also we can B+-collapse it to a point, even if the space contains infinite-chains, finally in Example 4.3.7. We show a space contains infinite chains and we can P-collapse to a point. but the space not contains any up-beat or down-beat points, so we can not start B-collapsing points, so the space is a core in the sense of Stong.

Recall, $C(X, Y)$ denotes the space of all continuous maps from X to Y in the compact-open topology. Kukiela introduce the classes of *finite-paths* and bounded-paths spaces and state the following Theorem 4.4.5.

If a space is a *C-core finite-path space*, then there is no map in $C(X, X)$ homotopic to id_X other than id_X .

We state in Definition 4.4.6. a space called *finite-bounded spaces*, under this space we can generalize the previous Theorem

Theorem. 4.4.10 *Let X be a C-core bounded space, If one of the following satisfies*

- X is finite bounded.
- $C(X, X)$ is Alexandroff.

there is no map in $C(X, X)$ homotopic to id_X other than id_X .

Moreover, two finite-bounded spaces are homotopy equivalent if and only if their cores are homeomorphic. Also we state more simply and extending proof. In section 4.5 we discuss some ways to convert a topological space to a simplicial complex and vice verse.

In Chapter 5 we will interested in a special kind of graphs called *cyclic graphs* introduced by Adamaszek, Michael, and Henry Adams. In their work they also state the the notion od *-ve dominated vertex*. We state a correspondence definition called *+ve dominated vertex* and we proof that If we have a cyclic graph, then:

There exist a -ve dominated vertex \Leftrightarrow There exist a +ve dominated vertex.

Moreover, the number of +ve dominated vertices is equal to the number of -ve dominated vertices.

Then we call the definition of undirected graph which is actually a 1-dimension simplicial complex, and study the relation between dominated vertices in both directed and undirected graphs.

In Section 5.2 we show that if we have a directed graph we can construct a preorder set *by reachability*, in the other direction, if we have a poset we can construct a directed graph, then we study the relationship between dominated vertices in directed graphs and the p-dominated points in the correspondence preorders space and vice verse.

Then we study the property of a special The directed graph denoted by \vec{C}_n^k In section 5.3 we state algorithms answer the following questions:

1. If we have a graph with an order on it vertices, how we can detect if this order yield to a cyclic graph by using the adjacency matrix?
2. If we have any matrix with 0 or 1 entries, can we reorder this matrix to detect if it can represent a cyclic graph or not?
3. How we can determine the dominated vertices from the adjacency matrix? and then determine the core.

Conclusions

I introduce and study the notion of P-dominated point in an Alexandroff space as a generalization of beat points (see Chapter 4) and I show that is good generalization of beat points.

The other two objectives are reached by designing several algorithms (see Chapter 2 and Chapter 3) and proving several results related with collapsibility over simplicial complexes and matroids as you can see all the long of this thesis. I also state some results and algorithms related to directed graphs. Before explained this in more detail, I will like to remark that I considered the most interesting is the results in Chapter 4.

Chapter 1

Preliminaries

Geometric shapes as curves, surfaces or their higher dimensions generalization are [continuous] which we cannot encode it directly using computers as a finite discrete structure.

We need to find representations of these shapes that capture enough their geometric structure and comply with the constraints inherent to the finiteness and discreteness of the underlying data structures by using a collection grow large easily but it have a simple elements.

Another difficulty, If the only representation of the data sampled as point clouds around unknown shapes, then we need to create a continuous space on top of this data that can encode the geometry and the topology of the underlying shape. *Simplicial complexes* give us a flexible solution to these difficulties. There is two notation to defined simplicial complexes, both of this notations can realised geometrically as a topological space.

In algebraic topology the notion of *sameness* usually represented by *homotopy equivalence*: Topological spaces X and Y are *homotopy equivalent* if there are maps $f : X \rightarrow Y$ and $g : Y \rightarrow X$ where the compositions $f \circ g$ and $g \circ f$ are homotopic to identity maps on X and Y , respectively. The homotopy equivalent spaces can be "deformed" from one to another. This notion can apply on the realizations of simplicial complexes, if the realizations are homotopy equivalent, then one of the simplicial complexes deformable into the other. But, this deformation may not pass through simplicial complexes, that

means during the homotopy may be there exist some $t \in [0, 1]$ such that the image of one of the compositions is not a simplicial complex.

So a homotopy equivalence may not always be created naturally (as geometric realizations) from a procedure in the category of abstract simplicial complexes. So we need a construction over simplicial complexes which induces a homotopy equivalence on its realizations in the best way, contiguous maps are created for this purpose.

This chapter consists of four sections: Section 1, provides a brief discussion of the required background in simplicial complex, we explain it in both abstract and geometric. In Section 2, we define simplicial maps. In Section 3, we introduce the concepts of homotopy and contiguous. In Section 4 we define the concept of chain complex and its homology groups.

1.1. Simplicial Complex and Simplicial Maps

The term simplicial complex refers to two concepts. The first one is a *geometric simplicial complex*, which is a geometric object in Euclidean space consisting of shapes called *simplices (polyhedrons)* of various dimensions, glued together according to certain rules. The second concept is that of an *abstract simplicial complex*, which is a family of sets that is closed under deletion of elements. Both of the two concepts are closely related: For every geometric simplicial complex, there is an underlying abstract simplicial complex describing its combinatorial structure. Conversely, one may realize any abstract complex as a geometric complex. In our study we are interested with the abstract concept. For more details the reader can go back to Munkres [36], Hatcher [22], Spanier [42], Jonsson [26] and Tammo [50].

The 0-simplex represented by a point, a 1-simplex is an edge, a 2-simplex is a triangle and a 3-simplex is a tetrahedron and so on. For completeness, we give a formal definition as follows.

Definition 1.1.1. Geometric k -simplex A geometric k -simplex σ is the convex hull of any $k + 1$ affinely independent points v_0, v_1, \dots, v_k in \mathbb{R}^d which means

$v_1 - v_0, \dots, v_k - v_0$ are linearly independent. Then, the simplex determined by them is the set of points:

$$\sigma = \left\{ \sum_{i=0}^k \theta_i v_i \mid \sum_{i=0}^k \theta_i = 1 \text{ and } \theta_i \geq 0 \text{ for } i = 0, \dots, k \right\}.$$

We called k the dimension of σ and v 's are its vertices.

A face of σ is a subsimplex of σ , namely, the simplex generated by a subset of the σ vertices.

A geometric simplicial complex is a set of simplices that are glued nicely, i.e. they only intersect each other at common faces.

Definition 1.1.2. Geometric simplicial complex A geometric simplicial complex $K = (V, S)$ consists of a set V , whose elements are called vertices, and a collection S of finite non-empty geometric simplices over V that satisfies the following the axioms:

- Every face σ of a simplex $\tau \in K$ is also in K .
- The intersection of any two simplices of X , if non-empty, is a face of each of them.

Example 1.1.3. The collection K_1 is a simplicial complex consist of two 2-simplices with a vertex in common, The simplicial complex K_2 has a common edge between its 2-simplices, but the collection K_3 is not a simplicial complex.



Figura 1.1: Simplicial complex.

Note that the k -simplex have a finite number of vertices but the simplicial complex not necessary to have finite number of simplices. A complex K is *finite* if V is finite, and *locally finite* if each vertex is contained in a finite number of simplices.

Remark 1.1.4. (*Geometric realization of geometric simplicial complex*) For a finite simplicial complex K in \mathbb{R}^d , its geometric realization $|K| \subseteq \mathbb{R}^d$ is the union of the simplices of K . The topology of K is the topology induced on $|K|$ by the standard topology in \mathbb{R}^d as a subspace. So we do not clearly make the distinction between a complex in \mathbb{R}^d and its geometric realization. Later in Remark 1.1.8, we will discuss the infinite case, and that the topology of an infinite geometric simplicial complex K coincides with the topology of the geometric realization $|K|$.

One is often interested in a geometric simplicial complex only for its homeomorphism type and its combinatorial information, But as long we identify a geometric simplicial complex with its set of simplices, also we can easily determine any simplex by using its vertex set (the 0-simplices). That means in most cases, the geometric information embedding into euclidean space is not necessary and one tends to be ignore it. This leads us to the following abstract simplicial complex definition.

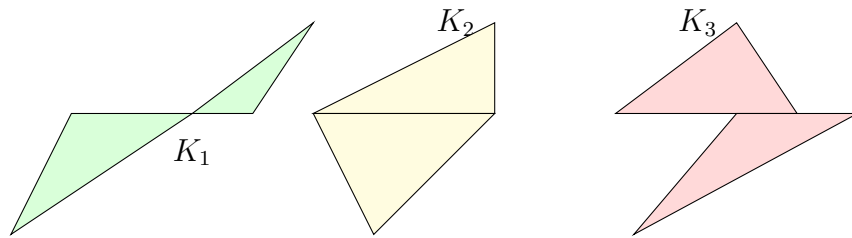
The most efficient description, containing all of the relevant information, comes from labelling the vertices and then specifying which sets of vertices together represent the vertices of simplices. If the set of vertices is countable, we can label them v_0, v_1, v_2, \dots . In general we can label by $v_i, i \in I$ for any indexing set I . Then if any set of vertices represent the vertices of a simplex, we can label the simplex as $v_{i_0}, v_{i_1}, \dots, v_{i_n}$.

Definition 1.1.5. Abstract simplicial complex A simplicial complex $K = (V, S)$ consists of a set V , called the set of vertices, and a set S of non-empty subsets of V , which is called the set of simplices, A set $\sigma \in S$ with $k+1$ elements is called a k -simplex of K and we say that its dimension is k . Satisfying the following axioms:

1. $\{v\} \in S$ for each $v \in V$.



2. If $\tau \in S$ and $\sigma \subset \tau$ is non-empty, then $\sigma \in S$.

By abuse of notation we will write $v \in K$ and $\sigma \in K$ if $v \in V$ and $\sigma \in S$. The dimension of K is the maximum over all dimensions of faces of K . If this maximum is not exist (i.e, K contains an n -simplex for all $n > 0$), then we say $\dim(K) = \infty$. If K is empty, its dimension is -1 . a complex K is finite if it has a finite number of simplices, and hence $\dim(K)$ will be finite. the converse is not true, for example a graph with infinite number of vertices is an infinite complex with dimension 1.

If a simplex σ is contained in another simplex τ , it is called a face of τ , and called a proper face of τ if $\dim(\tau) = \dim(\sigma) + 1$, i.e $\tau = \sigma \cup \{v\}$ for some $v \in \sigma$.

A face σ is a maximal face of K if there is no face τ of K such that $\sigma \subsetneq \tau$. A simplicial complex is called pure (or homogeneous) if all its maximal simplices have the same dimension.

We will write 'complex' or 'simplicial complex' instead of abstract simplicial complex. It is clear that any simplex σ has a finite number of faces, because any face of a face of σ is itself a face of σ .

Example 1.1.6. Let $V = \{a, b, c, d\}$, we write, a to be the simplex $\{a\}$, ab instead of $\{a, b\}$, and so on.

$$S = \{\emptyset, a, b, c, d, ab, ac, bc, abc, cd, ad\}$$

The set $K = (V, S)$ form a simplicial complex.

Definition 1.1.7. A subcomplex of a simplicial complex K is a simplicial complex L such that $V_L \subseteq V_K$ and $S_L \subseteq S_K$.

For $n \geq -1$, the n -skeleton $K^{(n)}$ of K is the subcomplex of K obtained by removing all faces of dimension greater than n .

For example, the 1-skeleton of k is a graph.

Abstract complex from geometric complex.

A geometric simplicial complex K in \mathbb{R}^d determines an abstract simplicial complex K' such that: the vertices of K' are the same vertices of K . Every set of vertices of the simplices of K is a simplex of K' .

There is a canonical way to construct one kind of simplicial complex from the other, and translating back then it yields an isomorphic construction. This allow us to abuse the concept of geometric simplicial complex with the abstract ones. So in our study we will interest in topological spaces generates by simplicial complexes from the view of abstract only, as follows:

Definition 1.1.8. Geometric realizations of abstract simplicial complexes [42]. *The abstract simplicial complexes are purely combinatorial objects. However, one may realize a finite simplicial complex as a geometric object in \mathbb{R}^n . There are various ways to choose the copies of the standard simplices and glue them, but it turns out that they produce homeomorphic spaces.*

The geometric realisation of finite K will be denoted as $|K|$, and $|K|$ itself is a geometric simplicial complex and can have the induced standard topology.

The procedure for finite complexes is roughly the following:

For finite abstract simplicial complex K with vertex set $V = \{v_1, v_2, \dots, v_n\}$ for some n , identify each vertex in K with a point in \mathbb{R}^n , such that V will represent in \mathbb{R}^n by $\{e_1, e_2, \dots, e_n\}$, where for any $i \in \{1, \dots, n\}$, e_i is the vector whose coordinates are all 0 except the i -th one which is equal to 1.

For each edge ab , draw a line segment between the points realizing the vertices a and b . Next, for each 2-simplex abc , fill the triangle with sides given by the line segments realizing ab , ac , and bc . Continue in this manner in higher dimensions. For example, realize each 3-simplex as a tetrahedron.

For any $k < n$, $[e_{i_0}, \dots, e_{i_k}]$ is a k -simplex of $|K|$ if and only if $[v_{i_0}, \dots, v_{i_k}]$ is a simplex of K .

In general, we can associate to any abstract simplicial complex $K = (V, S)$ (finite or infinite) a topological space $|K|$ called its geometric realization, define $|K| = \{\alpha : V \rightarrow [0, 1]\}$ satisfying the two conditions:

- For any α , $\{v \in V : \alpha(v) > 0\}$ is a simplex in K .
- For any α , $\sum_{v \in V} \alpha(v) = 1$.

If $K = \emptyset$, we define $|K| = \emptyset$.

A realising of K has two typical topologies, If K is locally finite, these topologies are identical.

The first topology is the metric topology defined by the metric d on $|K|$ as following:

$$d(\alpha, \beta) = \sqrt{\sum_{v \in V} [\alpha(v) - \beta(v)]^2}$$

The second topology on $|K|$ is called the weak topology, Whitehead topology or coherent topology whose closed sets are the sets that intersect each simplex in a closed subset. that's mean, $U \subseteq |K|$ is closed (or open) in the coherent topology if and only if $U \cap |\sigma|$ is closed (or open) in $|\sigma|$ for each $\sigma \in K$, where $|\sigma|$ is called the closed (affine) simplex in the geometric realization $|K|$ defined by:

$$|\sigma| = \{\alpha \in |K| : \alpha(v) \neq 0 \Rightarrow v \in \sigma\}$$

and $|\sigma|$ is topologized so that this identification is a homeomorphism. The weak topology is the largest topology showing that the inclusion $|\sigma| \hookrightarrow |K|$ is continuous.

In [41] introduce a new topology to realise a simplicial complex called the *box topology* which is finer than the metric topology and coarser than the weak topology. Since the common topology used by most authors is the weak topology, we will build the geometric realisation on this topology in our work.

Example 1.1.9. Here, the geometric realizations of the simplicial complexes in Example 1.1.6 in \mathbb{R}^2 . Since the label of each face is given by the vertices it contains, so it suffices to only label the vertices in the realization.



Figura 1.2: Geometric realization of a simplicial complex

Definition 1.1.10. A topological space X is said to be triangulable if there exists a simplicial complex K , and a homeomorphism $f : |K| \rightarrow X$, (some authors called X a polyhedron).

A triangulable space can have more than one triangulation, as example, S^1 has a triangulation as a complex K such that $|K|$ is homeomorphic to the boundary of an equal sided triangle; but also it can be triangulated by a simplicial complex where $|K|$ is a regular polygon with vertices in S^1 . Next we will show one triangulation of a sphere.

Example 1.1.11. We can shortly determine a simplicial complex by its maximal sets, For example $\{abc, abe, aed, acd, Abc, Abe, Aed, Acd\}$, spanned the simplicial complex K contains six 0-simplices, twelve 1-simplices and eight 2-simplices (triangles).

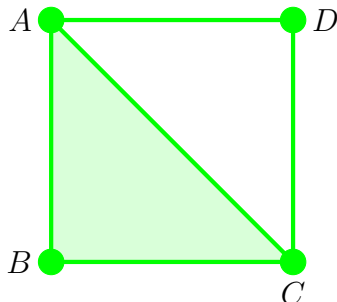
On the left, the geometric realization of the this complex on the space \mathbb{R}^3 . And on the right a sub-complex of this complex K generates by removing one of its maximal faces (triangle) realise in \mathbb{R}^2 .



Figura 1.3: Simplicial complex.

The complex on the right, is an interested famous example of a simplicial complex, which we will analysis its property in Chapter 2, and Chapter 3.

Theorem 1.1.12. *If a simplicial complex K can realize in \mathbb{R}^n , then K is locally finite and countable with $\dim(K) < n$. Conversely, if K is locally finite and countable with $\dim(K) < n$, then K can be realized in \mathbb{R}^{2n+1} .*

Definition 1.1.13. [37] *A complex K is connected, if it cannot be represented as the disjoint union of two or more non-empty subcomplexes.*

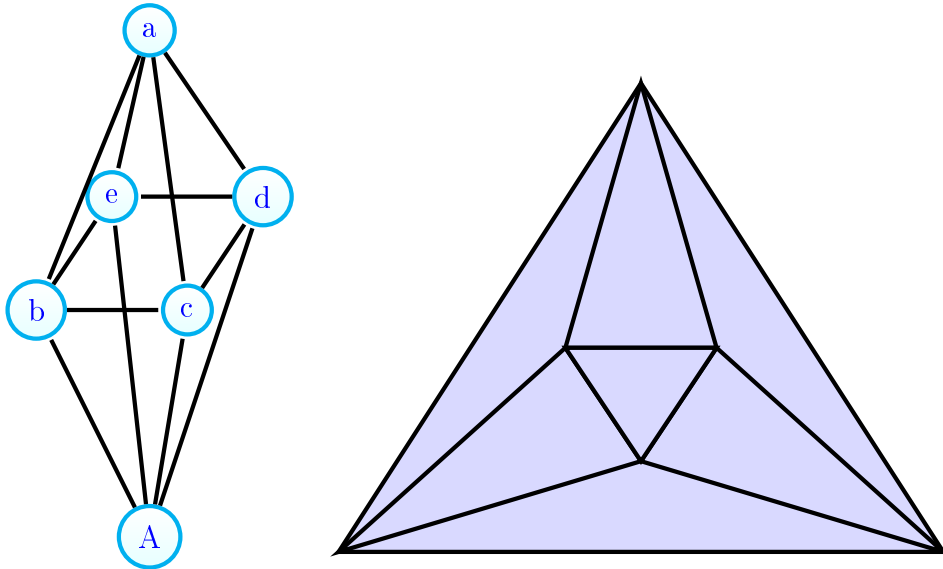
A geometric complex is path-connected if there exists a path made of 1-simplices from any vertex to any other.

A simplicial complex is path-connected if and only if it is connected.

1.2. Simplicial Maps

The appropriate notion of a morphism between two simplicial complexes is the simplicial map, such that the image of vertices is a vertices and the images of a simplex yields to a simplex. Simplicial maps induce continuous maps between the underlying geometric realization of the simplicial complexes.

Definition 1.2.1. [35] *Let $K = (V_K, S_K)$ and $L = (V_L, S_L)$ be two abstract simplicial complexes. A simplicial map from K to L is a function $\varphi : V_K \rightarrow V_L$ such that, if $\{v_0, v_1, \dots, v_r\}$ is a simplex in S_K , then $\{\varphi(v_0), \varphi(v_1), \dots, \varphi(v_r)\}$ is a simplex in S_L .*

A simplicial map $\varphi : K \rightarrow L$ induces a map of the underlying topological spaces,

$$|\varphi| : |K| \rightarrow |L|$$

defined by linear extension of the map on points, such that $x \in |K|$ represented as:

$$x = \sum_{i=0}^r \theta_i v_i \quad \sum_{i=0}^r \theta_i = 1, \theta_i \geq 0$$

Then define,

$$|\varphi|(x) = \sum_{i=0}^r \theta_i \varphi(v_i)$$

.

Note, φ need not be an injection on vertices, $|\varphi|$ is always well-defined. Also the composite of simplicial maps are simplicial maps.

Definition 1.2.2. *(Isomorphism of abstract simplicial complexes.)*

Let $K = (V_K, S_K), L = (V_L, S_L)$ are two abstract simplicial complexes are isomorphic, if there exists a bijection $f : V_K \rightarrow V_L$ such that $\{v_0, \dots, v_k\} \in S_K$ if and only if $\{f(v_0), \dots, f(v_k)\} \in S_L$. And we write $K \cong L$.

So a bijective simplicial map whose inverse is also a simplicial map is an isomorphism. We have the following relations between simplicial complexes and their realizations.

Proposition 1.2.3. *Let $\varphi : K \rightarrow L$, induces a map between two simplicial complexes, $|\varphi| : |K| \rightarrow |L|$, then:*

1. *If φ is a simplicial map, then $|\varphi|$ is continuous.*
2. *If φ is injective, so is $|\varphi|$.*
3. *If φ is an isomorphism, then $|\varphi|$ is a homeomorphism.*

So, any two isomorphic abstract simplicial complexes generates a homeomorphism between their geometric realizations.

The underlying spaces of any two geometric realizations of the same abstract simplicial complex are homeomorphic.

So it is common to relate the topological properties of these realisations spaces to the finite complex itself. as example, If we claims that a finite abstract simplicial complex K is homeomorphic or homotopy equivalent to a topological space X , it is meant that $|K|$ is homeomorphic or homotopy equivalent to X .

Example 1.2.4. *An interesting examples of simplicial maps, which will be critical for our development of minimize simplicial complex, are the simplicial maps that collapse simplices, as an exampl:*

Suppose we have K as a 3-simplex $[v_0, v_1, v_2, v_3]$, one of whose faces is the 1-simplex $[v_0, v_1]$ as a subcomplex L . Assume the simplicial map $f : K \rightarrow L$ determined by $f(v_0) = v_0, f(v_1) = v_1, f(v_2) = v_1, f(v_3) = v_1$, the 3-simplex collapses down to the 1-simplex. The great useful of simplicial map and collapse concepts (discuses in Chapter 2) is a way to preserve information so we can still see the image of the 3-simplex hiding in the 1-simplex as a minimize simplex and hence minimize the size of data in applied analysis. We will study when this operation get a homeomorphism between the original complex and the subcomplex.

Definition 1.2.5. [22] *A category \mathfrak{C} consists of three things:*

1. *A collection $Ob(\mathfrak{C})$ of objects.*
2. *Sets $Mor(X, Y)$ of morphisms for each pair $X, Y \in Ob(\mathfrak{C})$, including the identity morphism $id = id_X \in Mor(X, X)$ for each X .*

3. A composition of morphisms is a function $\circ : \text{Mor}(X, Y) \times \text{Mor}(Y, Z) \rightarrow \text{Mor}(X, Z)$ for each $X, Y \in \text{Ob}(\mathfrak{C})$, such that $f \circ \text{id} = f$, $\text{id} \circ f = f$, and $(f \circ g) \circ h = f \circ (g \circ h)$.

Definition 1.2.6. A functor \mathcal{F} from a category \mathfrak{C} to a category \mathfrak{D} assigns to each object X in \mathfrak{C} an object $\mathcal{F}(X)$ in \mathfrak{D} and to each morphism $f \in \text{Mor}(X, Y)$ in \mathfrak{C} a morphism $\mathcal{F}(f) \in \text{Mor}(\mathcal{F}(X), \mathcal{F}(Y))$ in \mathfrak{D} , such that $\mathcal{F}(\text{id}) = \text{id}$ and $\mathcal{F}(f \circ g) = \mathcal{F}(f) \circ \mathcal{F}(g)$.

Since the composition of simplicial maps is a simplicial map, the collection of simplicial complexes forms a category denote SCom where the morphisms are the simplicial maps. So the geometric realization is a functor:

$$|\mathcal{F}| : \text{SCom} \longrightarrow \text{Top}.$$

1.3. Homotopy and Contiguous

Given topological spaces X and Y , the set of all continuous functions between two topological spaces X and Y is typically quite large and complicated even in simple cases. To classify this functions, and then restrict attention to equivalence classes to study this function, the deepest and most useful equivalence relation is the concept of *homotopy*. Then we classify the topological spaces in equivalence classes using the idea of *homotopy equivalence*.

Using homotopy concept we can put two functions in the same equivalence class whenever we can continuously and smoothly transition from one to the other as a parameter $t \in [0, 1]$ move continuously from 0 to 1, and vice versa.

Definition 1.3.1. Let X, Y be topological spaces, and $f, g : X \rightarrow Y$ continuous maps. A homotopy from f to g is a continuous function

$$H : X \times [0, 1] \longrightarrow Y \text{ such that } H(x, 0) = f(x), H(x, 1) = g(x)$$

for all $x \in X$. We say that f is homotopic to g if such a homotopy exists, and denote this by $f \simeq g$.

Some topological spaces X and Y can be transformed into one to another by bending, shrinking and expanding operations, the following notation describe these spaces:

Definition 1.3.2. A homotopy equivalence *between topological spaces X and Y* is a continuous map $f : X \rightarrow Y$ which has a homotopy inverse, hence such that there exists a continuous map $g : Y \rightarrow X$ and homotopies

$$g \circ f \simeq id_X \text{ and } f \circ g \simeq id_Y.$$

If such a pair f and g exists, then X and Y are said to be homotopy equivalent, or X and Y have the same homotopy type.

Being homotopy equivalent is evidently an equivalence relation. So homotopies between functions can be used in order to produce an equivalence relation on topological spaces as well. A homeomorphic spaces are always homotopy equivalent, but the converse does not hold.

Definition 1.3.3. A topological space X is contractible if the identity map on X is homotopic to some constant map, i.e X is homotopy equivalent to a one-point space.

Example 1.3.4. A solid triangle is an obvious example of contractible space which can transformed smoothly to a point. Hatcher [22] introduce his example of a 2-dimensional subspace of \mathbb{R}^3 known as Bing's house with two rooms, which is contractible but not in any obvious way, To check contractibility, one can imagine a deformation retraction of a solid cube onto Bing's house. you can push through the tunnel from the left and hollow out the down room through the tunnel, and similarly for the upper room.

More interested features of Bing's house, comes in Example 1.3.12, Example 2.1.6, and Example 2.4.5.



Figura 1.4: Bing's house with two rooms.

A *retraction* r is a continuous mapping from a topological space X into a subspace $A \subset X$ (A called a *retract*), where r preserves the position of all points in that subspace A . A deformation retraction is a homotopy between a retraction r and the identity map on X , as follows.

Definition 1.3.5. A subspace A of X is called a deformation retract of X if there is a homotopy $F : X \times I \rightarrow X$ (called a deformation retraction) such that for all $x \in X$ and $a \in A$,

- $F(x, 0) = x$,
- $F(x, 1) \in A$, and

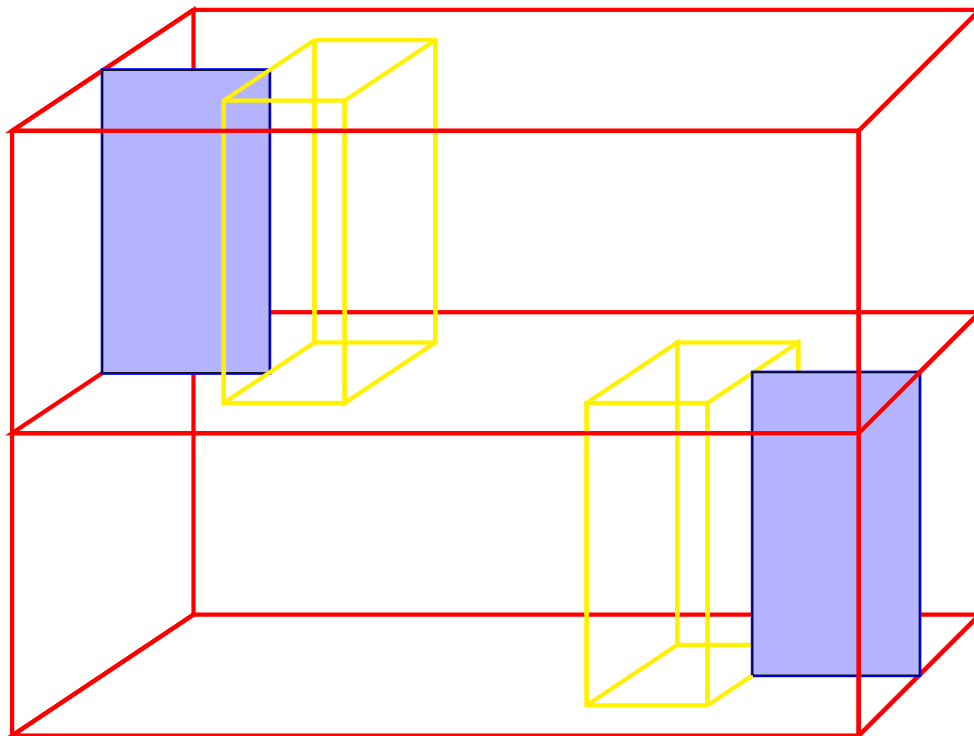
- $F(a, 1) = a$.

A deformation retraction F is called a strong deformation retraction, if we add the requirement that:

$F(a, t) = a$ for all $t \in [0, 1]$ and $a \in A$.

So a deformation retraction is a special case of a homotopy equivalence. And a strong deformation retraction fixed the points in A throughout the homotopy.

The homotopy describes a continuous deformation of a function f into g , at time 0 we have the function f , and at time 1 we have the function g . There is two ways to describe the similar concept (The homotopy concept) in simplicial complexes, The first one related to it's geometric realization as follows:

Definition 1.3.6. *Two simplicial complexes K and L are said to be homotopy equivalent, or have the same homotopy type, whenever their geometric realizations $|K|$ and $|L|$ are homotopy equivalent in the sense of Definition 1.3.2.*

Note that, for each dimension $k \geq 0$, the geometric realization of any k -simplex is homotopy equivalent to a point (contractible).

The second way to describe the (Homotopy) as combinatorial way in simplicial complex is the notion of *contiguity classes* of simplicial maps using *contiguous maps* which are homotopic at the level of geometric realizations, but this notion is strictly stronger than usual homotopy.

Definition 1.3.7. *Suppose $\varphi, \psi : K \rightarrow L$ are simplicial maps. Then φ and ψ are contiguous, if for every simplex $\sigma \in K$, $\varphi(\sigma) \cup \psi(\sigma)$ is a simplex in L . The equivalence classes of the equivalence relation generated by contiguity are called contiguity classes. If two simplicial maps $\varphi, \psi : K \rightarrow L$ lie in the same contiguity class, we will write $\varphi \sim \psi$.*

Notice that when we use the idea of contiguity between simplicial complexes we use this notation \sim , and when we think of the usual notation of homotopy between topological spaces we use this notation \simeq .

Lemma 1.3.8. [8] *Let $\varphi, \psi : K \rightarrow L$ be simplicial maps. Then φ and ψ are contiguous if and only if φ and ψ satisfy the contiguity property for every maximal simplex of K .*

The idea of contiguity respect the composition as follows:

Lemma 1.3.9. *If $\varphi_1, \psi_1 : K \rightarrow L$ and $\varphi_2, \psi_2 : L \rightarrow M$ are simplicial maps such that $\varphi_1 \sim \psi_1$ and $\varphi_2 \sim \psi_2$, then $\varphi_2\varphi_1 \sim \psi_2\psi_1$.*

Definition 1.3.10. *For a simplicial map $\varphi : K \rightarrow L$, if there exists $\psi : L \rightarrow K$ such that $\psi\varphi \sim 1_K$ and $\varphi\psi \sim 1_L$, we say that φ is a strong equivalence. If there is a strong equivalence from K to L we say K and L are strongly equivalent denoted by $K \sim L$. This relation \sim is an equivalence relation. A complex K is strongly contractible if it is strongly equivalent to the single vertex complex, i.e. if the identity map on K is contiguous to the constant map sending K to one of its vertices.*

Simplicial maps in the same contiguity class have homotopic topological realization.

Theorem 1.3.11. [3] *If $\varphi, \psi : K \rightarrow L$ are contiguous, then $|\varphi|, |\psi| : |K| \rightarrow |L|$ are homotopic.*

Proof. Since both φ and ψ are simplicial maps, then by Proposition 1.2.3, both $|\varphi|$ and $|\psi|$ are continuous maps. Let $H : |K| \times I \rightarrow |L|$ such that for any $x \in |K|$

$$H(x, t) = (1 - t)|\varphi|(x) + |\psi|(x)$$

such that $H(x, 0) = |\varphi|(x)$, $H(x, 1) = |\psi|(x)$. For prove H is continuous, follow Barmak [6][Appendix A.1.2.] or May [30]. \square

The converse of this theorem is not true, as the following example shows. However, there is a partial converse of this theorem adding some conditions to the complex. So the sense of contiguity is the best analogue of homotopy in the world of abstract simplicial complexes.

Example 1.3.12. *A standard examples is the contractible space, Bing's house with two rooms (see Example 1.3.4) which can be exhibited as realizations as a 2-simplicial complexes that are not strongly equivalent to one vertex complex.*

There is a functor from the contiguity category of simplicial complex to the homotopy category of topological spaces which assigns to the complexes K, L , their realization spaces $|K|, |L|$. And to the class of simplicial maps $[\varphi]$ the homotopy class $[[\varphi]]$ For more details, see Spanier [42] Corollary 3.5.3.

1.4. Chain Complex and Homology

Homology, is a central concept in algebraic topology and one of the most important homotopical invariants of spaces. The construction of homology proceeds in two stages: First one associates to a space a so-called *chain complex*. Then the chain complex yields, by algebra, the homology groups. For more details the reader can follow Munkres [36] [23], [24] and [26]. Lets we start with a recall of chain complex and chain maps.

Definition 1.4.1. (Chain Complex) A chain complex $C_\bullet = (C_n, d_n)$ is a sequence of abelian groups $\{C_n : n \in Z\}$ along with homomorphisms

$$d_n : C_n \longrightarrow C_{n-1}$$

such that

$$d_n \circ d_{n+1} = 0, n \in Z.$$

We refer to d_n as a boundary map.

One typically illustrates a chain complex as a sequence with arrows between the groups in the following manner:

$$C_\bullet : \cdots \xrightarrow{d_{n+2}} C_{n+1} \xrightarrow{d_{n+1}} C_n \xrightarrow{d_n} C_{n-1} \xrightarrow{d_{n-1}} \cdots$$

An interested special case of chain complex will discuss next in Definition 1.4.6

Definition 1.4.2. (Chain map). A chain map between two chain complexes $f_\bullet : C_\bullet \longrightarrow D_\bullet$ is a sequence of homomorphisms $f_n : C_n \longrightarrow D_n$ such that

$$f_{n-1} \circ d_n = d_n \circ f_n$$

To define homotopies for chain complexes, we have a completely algebraic definition for chain homotopies.

Definition 1.4.3. (Chain homotopy). A chain homotopy *between chain maps* $f_\bullet, g_\bullet : C_\bullet \rightarrow D_\bullet$ is a sequence of homomorphisms $h_n : C_n \rightarrow D_{n+1}$ such that

$$g_n - f_n = d_{n+1} \circ h_n + h_{n-1} \circ d_n.$$

Being chain homotopic is an equivalence relation on the set of chain maps.

For every simplicial complex we want to associate a chain complex, then we will define the concept of homology. First we need to discuss the order over a simplex vertices and the notation of orientation:

Definition 1.4.4. (Orientation) [36] [35] *If we have an k -simplex of K represented as $\sigma_k = \{v_0, v_1, \dots, v_k\}$, we can order the elements of σ_k in $(k+1)!$ different ways, two orderings said to be equivalent, if they differ from one to another by an even permutation.*

If $\dim(\sigma_k) = k > 0$ the ordering over σ_k vertices falls in two equivalence classes and each class called an orientation of σ_k . So every k -simplex has two orientations. A 0-simplex has only one ordering; its orientation is given by ± 1 .

An oriented simplex is a simplex σ together with an orientation of σ denoted by the equivalence class $[v_0, v_1, \dots, v_k]$.

A simplicial complex K is oriented simplicial complex if all its simplices are oriented.

Technically, to give an orientation to a simplex, first we order its vertices in all possible ways, then select an ordering class from the two possible classes. Now we move to the complex K , first take a partial ordering of the set V such that the set of vertices of each simplex is totally ordered, so we obtain an ordering class (an orientation) for each simplex and hence K is oriented.

For example, one way to orient a finite simplicial complex is to order naturally its vertices and let this ordering induce an orientation on all the simplices of K .

Definition 1.4.5. (*Chains*). Let K be an oriented simplicial complex. A n -chain is a formal linear combination of finite number of n -simplices $\sigma_i \in K$ with coefficients a_i in some ring.

$$\sum_i a_i \sigma_i$$

We define addition of n -chains:

$$\sum_i a_i \sigma_i + \sum_i b_i \sigma_i = \sum_i (a_i + b_i) \sigma_i$$

Since the coefficients form an additive group, this gives us the group of n -chains $C_n = C_n(K)$.

We are interested in $C_n = 0$ for all $n < -1$ and for $n = -1$ define $C_{-1} = \mathbb{Z}$.

For $n \geq 0$, we define the notion of the boundary maps ∂_n over a simplicial complexes which is the special case of the notation of the boundary maps d_n .

Definition 1.4.6. (*Boundary Operator*) Let K be a simplicial complex over V . Let n and i be two integers such that $0 \leq i \leq n \leq 1$. Then the boundary operator ∂_i^n is the map defined by:

$$\partial_i^n : C_n(K) \rightarrow C_{n-1}(K)$$

$$\partial_i^n([v_0, \dots, v_n]) = [v_0, \dots, v_{i-1}, \widehat{v}_i, v_{i+1}, \dots, v_n],$$

where \widehat{v}_i indicates that this i -th vertex is deleted from the sequence v_0, \dots, v_n , so that a $(n-1)$ -simplex is obtained.

We might then wish to say that the boundary of the simplex (v_0, v_1, \dots, v_n) is the sum of its various $(n-1)$ faces. So we define:

$$\partial_n([v_0, v_1, \dots, v_n]) = \sum_{i=0}^n (-1)^i [v_0, \dots, v_{i-1}, \widehat{v}_i, v_{i+1}, \dots, v_n].$$

Heuristically, the signs are inserted to take orientations into account, so that all the faces of a simplex are coherently oriented.

In this document, we will focus on the *simplicial chain complexes* $C_\bullet(K)$ over a simplicial complex together with the boundary function ∂ . Which typically illustrates by the following sequence.

$$C_\bullet(K) : \cdots \xrightarrow{\partial_{n+2}} C_{n+1} \xrightarrow{\partial_{n+1}} C_n \xrightarrow{\partial_n} C_{n-1} \xrightarrow{\partial_{n-1}} \cdots$$

An important property of boundary maps is that the boundary of a boundary is always zero (i.e. the composition $\partial_n \circ \partial_{n+1} = 0$ for each n) this yields that the above sequence is a chain complex.

Definition 1.4.7. *Let K, L be two simplicial complex, and let $C_\bullet(K) = (C_n, \partial_n)$, $C_\bullet(L) = (D_n, \partial_n)$ be the corresponding simplicial chain complexes of K, L respectively.*

If there exist a simplicial map $f : K \rightarrow L$, then we have an induced homomorphism $f_n : C_n \rightarrow D_n$ by defining it on oriented simplices as follows: For a simplex $[v_0, v_1, \dots, v_k]$

$$f_n([v_0 \dots, v_k]) = \begin{cases} f(v_0), \dots, f(v_k) & \text{if } f(v_0), \dots, f(v_k) \text{ are distinct} \\ 0 & \text{otherwise} \end{cases}$$

This map is well defined, the sequence of homomorphisms is called the chain maps induced by the simplicial map f :

$$f_\bullet : C_\bullet(K) \rightarrow C_\bullet(L)$$

The chain map induced by the composition $g \circ f : K \rightarrow M$ of two simplicial maps $f : K \rightarrow L$ and $g : L \rightarrow M$ is the composition of the chain maps induced by these simplicial maps.

Theorem 1.4.8. *If $f, g : K \rightarrow L$ are contiguous then there exist a chain homotopy between f and g .*

Now, we are ready to define the *Homology* concept, for a boundary map $\partial_n : C_n(K) \rightarrow C_{n-1}(K)$ we have:

$$\begin{aligned} \ker \partial_n &= \{z \in C_n : \partial_n(z) = 0\}, \\ \operatorname{im} \partial_n &= \{b \in C_{n-1} : \exists z \in C_n : b = \partial_n(z)\}. \end{aligned}$$

Definition 1.4.9. (*Cycles*) A n -cycle is a n -chain whose boundary is zero. The group of n -cycles is

$$Z_n = Z_n(K) := \ker \partial_n.$$

Definition 1.4.10. (*Boundaries*). A n -boundary is a n -chain that is the boundary of some $(n+1)$ -chain. The group of n -boundaries is

$$B_n = B_n(K) := \operatorname{im} \partial_{n+1}.$$

The collection of Z_n 's and B_n 's together with addition form subgroups of C_n while the property $\partial_n \circ \partial_{n+1} = 0$ shows that $B_n \subseteq Z_n \subseteq C_n$.

Definition 1.4.11. For the simplicial chain complex $C_\bullet(K)$ associated to a simplicial complex K , we define the simplicial homology $H_n(K) = H_n(C_\bullet(K))$ in degree n of $C_\bullet(K)$ to be the quotient

$$H_n(K) = \frac{Z_n(C_\bullet)}{B_n(C_\bullet)} = \frac{\ker d_n}{\operatorname{im} d_{n+1}}.$$

The n -th Betti number of C_\bullet , denoted by $\beta_n(C_\bullet)$, is the rank of the n -th homology group of C .

the n -th Betti number of an complex K measures the number of n holes of K ; to be more concrete, β_0 measures the number of connected components, β_1 measures the number of 2-dimension hole, and the Betti numbers β_n , with $n > 0$, measure higher dimensional connectedness.

Example 1.4.12. The full simplex on a vertex set V is the simplicial complex 2^V of all subsets of V , writing $d = |V| - 1$.

If K is a full simplex for some $d \geq 0$, then $H_n(K) = 0$ for all $n \geq 0$.

Theorem 1.4.13. *A chain map f_\bullet induced by a simplicial maps $f : K \longrightarrow L$*

$$f_\bullet : C_\bullet(K) \longrightarrow C_\bullet(L)$$

induces a homomorphism:

$$f_* : H_n(C_\bullet(K)) \longrightarrow H_n(C_\bullet(L))$$

$$[c] \mapsto [f(c)]$$

Furthermore, if f_\bullet and g_\bullet are chain homotopic, then $f_ = g_*$.*

This theorem together with Theorem 1.4.8 yield to the following result

Lemma 1.4.14. *If $f, g : K \longrightarrow L$ are contiguous simplicial maps, then*

$$f_* = g_* : H_n(K) \longrightarrow H_n(L)$$

for all n .

Definition 1.4.15. [26] *For K a simplicial complex, define the n -th homology group of the space $|K|$ to be the n -th homology group of K , i.e.*

$$H_n(|K|) = H_n(K).$$

Theorem 1.4.16. [22] *If K and K' are two simplicial complexes with homotopy equivalent geometric realizations then their homology groups are isomorphic and their Betti numbers are equal.*

Theorem 1.4.17. [37] *If K_1, \dots, K_p is the set of all connected components of a complex K , then the homology group $H_n(K)$ is isomorphic to the direct sum $H_n(K_1) \oplus \dots \oplus H_n(K_p)$.*

If K is a connected complex, then $H_0(K)$ over \mathbb{Z} is isomorphic to \mathbb{Z} .

Theorem 1.4.18. *If we have the direct sum of two chain complexes $C_\bullet = C'_\bullet \oplus C''_\bullet$, then*

$$H_n(C_\bullet) = H_n(C'_\bullet) \oplus H_n(C''_\bullet)$$

Chapter 2

Comparison between 3 collapse types

The first attempt to classify the simplicial complexes in an equivalent classes was made by Whitehead in 1938 [47], his famous strategies was to minimize and simplify finite simplicial complexes through a sequence of removing simplices called *free faces* to reach a minimal complex called *the core*, this operation called *The Collapse*, he assume that simplicial complexes belong to the same equivalent class if they have an isomorphic cores. But this attempt did not success since there is many cores of the same complex depending on the steps of removing the free faces and those cores are not unique up to isomorphisms, In 2012 Barmak [6] success to apply this idea, he minimize finite simplicial complexes using *strong collapse strategy* which we will discuss in Section 2. In this section, we will consider the relationship of homotopy equivalences in finite simplicial complexes after collapsing and its realization as topological spaces.

First we introduce, an important concept here is the notion of *simple homotopy equivalence* due to Whitehead which allows to move from a complex K to another L through a sequence of complexes, each one generate by removing and adding free faces to the previous one.

We define strong collapse in Section 2, edge collapse in Section 4, with provides a brief discussion about homotopical and homological property for

each concept. In Section 3, we create an algorithm to partition the maximal simplices of a complex into strong collapse subcomplexes. Finally in Section 5, we create another algorithm to partition the maximal simplices of a complex into edge collapse subcomplexes, with provide a code for each algorithm in Python.

2.1. Collapse concepts

The standard references for this section are Whitehead [48], [49] Cohen [14], and Barmak [7]

Definition 2.1.1. *Let K be a simplicial complex, let σ and τ be simplices of K , we say a simplex σ is a free face of τ if the following hold:*

- τ is maximal in K .
- σ is a proper face of τ , ($\dim(\tau) = \dim(\sigma) + 1$).
- τ is the unique simplex of K contains σ .

It's easy to show that the family $K \setminus \{\sigma, \tau\}$ is a simplicial complex.

Definition 2.1.2. *Related to the previous concept, we have the following definitions:*

- *The procedure of removing both simplices τ and its free face σ from K called elementary collapse from K to $K \setminus \{\sigma, \tau\}$, denoted by $K \searrow K \setminus \{\sigma, \tau\}$.*
- *Adding a free face to the complex called an elementary expansion.*
- *We say there is a collapse from a simplicial complex K to its sub-complex L (or an expansion $L \nearrow K$), if there exists a series of elementary collapses from K to L , denoted as $K \searrow L$.*
- *A complex K is collapsible if there is a collapse from K to a point.*
- *Two complexes K and L have the same simple homotopy type (or they are simple homotopy equivalent) if there is a sequence $K = K_1, K_2, \dots, K_n = L$ such that $K_i \searrow K_{i+1}$ or $K_i \nearrow K_{i+1}$ for all i .*

Example 2.1.3. *The simplicial complex in Example 1.1.11 can elementary collapse many times until we reach a point, as we clear in the following realization.*



Figura 2.1: Collapse a simplicial complex

Theorem 2.1.4. *Let K a finite simplicial complex, and we have an elementary collapse $K \searrow K \setminus \{\sigma, \tau\} = K_0$ then:*

- *the underlying geometric realization $|K_0|$ is homotopy equivalent to $|K|$. This homotopy equivalence fixed the points in $K \setminus \{\sigma, \tau\}$, hence, collapse is a strong deformation retract.*
- *Moreover, If K collapse to L , there is a retraction map $|r| : |K| \rightarrow |L|$ which is a strong deformation retraction.*

Corollary 2.1.5. *A collapsible finite simplicial complex is contractible*

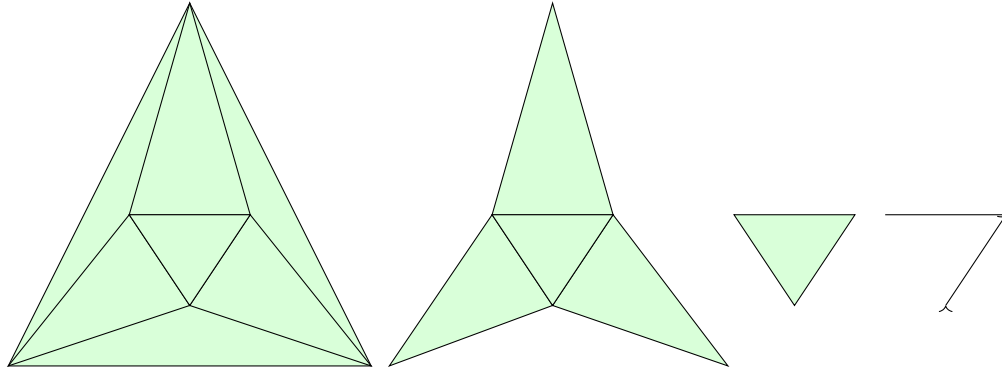
The converse of the previous corollary is not true, as the following example shows.

Example 2.1.6. *We show that Bing's house in Example 1.4 is contractible. However, Bing house has a realizations as a simplicial complex, denote K_B that does not have any free face, hence it can not collapsible to a point.*

But we can, through a sequence of expansions and collapses start with the Bing

house realization K_B and then expansion it to a solid cube which can now collapse to a point.

So we can say that Bing house is contractible with a not collapsible realization K_B , but this realization K_B have the same simply homotopy type to a point.

Whitehead, Barmak and McCord published many results to study the relations between collapsible simplicial complexes and contractible T_0 finite space, also they discuss the relation between collapse and homotopy or *weak homotopy*

Theorem 2.1.7. *If we have an elementary collapse $K \searrow K' := K \setminus \{\sigma, \tau\}$. For this maximal simplex τ , we can define a new chain complex $C_\bullet(K'')$ where the only none zero groups are $C_d(K'')$ generated by τ , and $C_{d+1}(K'')$ generated by $\partial(\tau)$, and all other $C_n(K'')$ are 0. In this case, $C_\bullet(K)$ splits as*

$$C_\bullet(K) = C_\bullet(K') \oplus C_\bullet(K'').$$

Since $C_\bullet(K'')$ is a chain complex generated by a simplex have a zero homology, by applying Theorem 1.4.18 we have the following results

Theorem 2.1.8. *[26] For any elementary collapse $K \searrow K' = K \setminus \{\sigma, \tau\}$, we have that $H_n(K) = H_n(K')$ for all n .*

Applying this theorem many times, we obtain the following important result.

Corollary 2.1.9. *[26] If there is a collapse from K to L , then $H_n(K) = H_n(L)$ for all n .*

Using the previous result, we have:

Corollary 2.1.10. *If a complex K is collapsible, then $H_n(K) = 0$ for all n .*

2.2. Strong Collapse and Homotopy

Deleting and minimise data are an important approach in topological data analysis. In this section we introduce a famous strategies to minimize and

simplify the finite simplicial complex through a sequence of deletion points, keeping the "same homotopy" property for every complex in this sequence as the original one, this procedure called *strong collapse* stated in Barmak [6].

Definition 2.2.1. (*Link definition*) Let σ be a simplex of the simplicial complex K . The link of σ in K is the simplicial complex

$$Lk(\sigma) = \{\tau \in K : \tau \cup \sigma \in K, \sigma \cap \tau = \emptyset\}.$$

If K and L are two disjoint complexes, the join $K * L$ (or KL) is the complex whose simplices are those of K , those of L and unions of simplices of K and L . A simplicial cone is the join aK of a complex K and vertex a called apex, not in K .

Geometrically, the cone aK can be thought of as increasing the dimension of each simplex of $|K|$ by joining all points of $|K|$ to a common disjoint point $|a|$ by line segments.

Lemma 2.2.2. *The geometric realisation of a simplicial cone is contractible.*

Theorem 2.2.3. *If K is a cone with apex a , then $H_n(K) = 0$ for every n .*

Definition 2.2.4. [9] *In a complex K , a vertex v is said to be dominated by a vertex $w \neq v$, if every maximal simplex that contains v also contains w . Other research equivalently, define a dominated vertex v , if the link of v is a simplicial cone on w , that is $Lk(v) = w * L$ where L is a sub-complex of K .*

Recall, that the set spanned by deleting one vertex from a simplicial complex is also a complex.

Definition 2.2.5. [6] *Related to the concept of dominated vertices, we have the following definitions:*

- We denote the deletion of the vertex v by $K \setminus v$, which is the full sub-complex of K spanned by the vertices different from v .
- An elementary strong collapse is the process of deletion of a dominated vertex v from K , denote with $K \searrow \searrow K \setminus v$. The converse of this process called elementary strong expansion.

- There is a strong collapse from a simplicial complex K to its sub-complex L , if there exists a series of elementary strong collapses start from K to L , denoted as $K \searrow \searrow L$ or $L \nearrow \nearrow K$.
- We say K, L have the same strong homotopy type, if there is a sequence of strong collapses and strong expansions that starts in K and ends in L .
- In particular, if $L = *$, so, K have the same strong homotopy type the of a point. If there is a sequence of elementary strong collapses from K to a point, K is called strongly collapsible.

Example 2.2.6. In the following realization, the complex K strong collapse through the sequence of subcomplexes K_1 , K_2 and $K_3 = *$, every step the vertex w dominated by v , we color $\text{link}(w)$ by green which is a cone in each subcomplex. So K is strong collapsible.



Figura 2.2: Strong collapse a simplicial complex

Remark 2.2.7. The usual notion of collapse is weaker than the notion of strong collapse, If K is a strong collapse to $K \setminus v$, then $\text{lnk}(v)$ is collapsible, and K collapse to $K \setminus v$.

The following example shows that the converse is not correct

Example 2.2.8. The simplicial complex realized in Example 1.1.11 dose not have any dominated vertices, so it is a core. however, as we shown that K is collapsible as well as contractible.

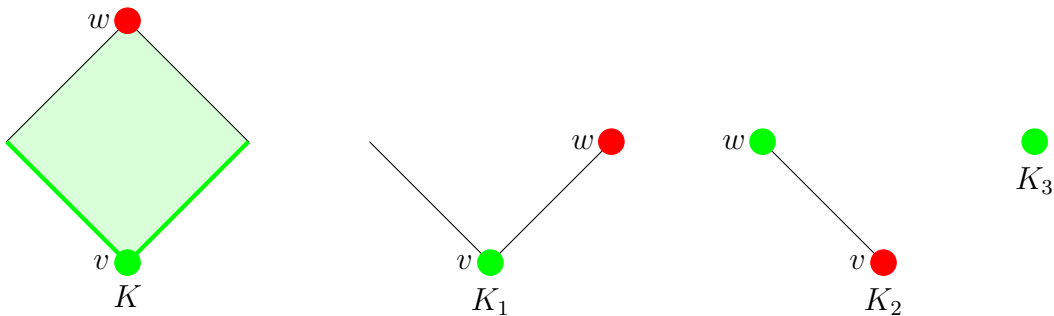
It is not hard to see that isomorphic complexes have the same strong homotopy type.

Recall from Definition 1.3.10, that $K \sim L$, means that K and L are strongly equivalent.

Theorem 2.2.9. *If we have a dominated vertex v in a complex K , then $K \sim K \setminus v$. In particular, if K, L have the same strong homotopy type, then $K \sim L$. Hence their geometric realization $|K|, |L|$ are homotopy equivalent.*

Applying this theorem, together with Theorem 1.4.16, we have the following result

Corollary 2.2.10. *If K and L have the same strong homotopy type, then their homology groups are isomorphic and their Betti numbers are equal, so for all n*

$$H_n(K) = H_n(L)$$

In particular, if K is collapsible, then $H_n(L) = 0$ for all n .

Definition 2.2.11. *Let K be a simplicial complex. The core of K is the sub-complex $K_0 \subseteq K$ such that, $K \searrow \searrow K_0$, in addition that K_0 has no dominated vertices.*

This definition is justified by the following theorem for finite cases which have been studied by Barmak [6].

Theorem 2.2.12. *[6] Every finite simplicial complex has a core and it is unique up to isomorphism. Two complexes have the same strong homotopy type if and only if they have isomorphic cores.*

The previous theorem guarantees that the order in which elementary strong collapses are performed is irrelevant since each sequence of such moves must yield the same core. So finally we have the following corollary follows Theorem 2.2.9

Corollary 2.2.13. *Finite simplicial complexes K, L are strongly equivalent if and only if they have the same strong homotopy type.*

In particular, a complex K is strongly collapsible to a vertex if and only if it is strongly equivalent to a vertex. Hence $|K|$ is strong deformation retracts to the one-point space (contractible).

Conclusion: The notion of equivalence according to contiguous maps (strong equivalence) is the same as that of equivalence according to strong collapses (strong homotopy type). Since the two notions are the same, they have the same effect when we applying the realization functor to the topological spaces. So if there is a strong collapse/strong equivalence from K to a subcomplex L , then there is homotopy equivalence between $|K|$ and $|L|$ (by Theorem 1.3.11). However, in fact this homotopy equivalence is a strong deformation retraction. In the category of spaces, the terminology of (collapsibility) over simplicial complexes also agrees with (contractibility) over topological spaces.

2.3. Strong collapse Algorithm

In this sections, we will state an algorithms to partition the maximal simplices which covers finite simplicial complex into strong collapsible sub-complexes. The idea of constructing this algorithm is to determined if the expansion is possible or not, so we start with a special vertex v to be the first complex $K_0 = \{v\}$, and extend K_0 through the maximal sets contains v , then we begin to perform strong elementary expansions to add more simplices.

This can undone by performing elementary strong collapses in the reverse order.

So, after a one full iteration for each such vertex v , we construct a sub-complex U_v which is strong collapsible.

Also with this algorithm, we can determine an upper bound for the following number which defined in [17].

Definition 2.3.1. The simplicial geometric category $gscat(K)$ of the simplicial complex K is the least integer $m \geq 0$ such that K can be covered by $m + 1$ strongly collapsible sub-complexes. That is, there exists a cover $U_0, \dots, U_m \subset K$ of K such that, for all $i \in \{0, \dots, m\}$, U_i have the same strong homotopy type of a vertex (i.e. $U_i \sim *$).

For instance, K is strong collapsible if and only if $gscat(K) = 0$. We need to state the following definition to construct the algorithm.

Definition 2.3.2. *Let $K = (V, S)$ be a simplicial complex, and let $Max(K)$ be the set of all maximal simplices in K . We call $v \in V$ a famous vertex to be one of the most frequency vertices through the maximal simplices.*

We mean by *totally color* that we color the simplex and all its faces with the same color.

Algorithm 1: Strong collapse algorithm.

Data: A non empty simplicial complex $K = (V(K), S(K))$.

```

1  $\mathcal{U} = \phi$  and color red all simplices in  $K$ .
2 while  $K! = \phi$  do
3   Set  $Max$  be the set of all current red maximal simplices.
4   Initialize  $i = 0$ .
5   Set  $U_i = \phi$ .
6   Set  $W = \{v : v \text{ is a famous vertex over } Max\}$ .
7   Pick a random vertex  $v \in W$ , then totally color green all maximal
   set containing  $v$ .
   /* Next, we will search for more dominated vertices */
8    $M_v = \{\sigma \in K : \text{for some vertex } w \in \sigma, \sigma - w \text{ is color green, and } w$ 
   color red\}.
9   while  $M_v! = \phi$  do
10    Pick  $\sigma \in M_v$ .
11    Color green  $\sigma$  and  $w$ .
12     $M_v = M_v$  /* Redefine  $M_v$ , as Line 8, and repeat the While
   loop. */
13  end
14   $U_i = \{\text{all currently green simplices}\}$ .
15  Color yellow all simplices in  $U_i$  and turn off green.
16   $\mathcal{U} = \mathcal{U} \cup \{U_i\}$ .
17   $S(K) = S(K) - S(U_i)$ . /* the rest of red simplices */
18   $K$  spanned by the new set of simplices  $S(K)$ .
19   $i = i + 1$ .
20 end

```

Result: \mathcal{U} cover K .
Each $U_i \in \mathcal{U}$ is strongly collapsible sub-complex.
Partition the maximal simplices $Max(K)$ covers K by the sets
 $U_i \cap Max(K)$.

```

21 Print( $\mathcal{U}$  )
22 Print(  $gscat(K) \leq i$  )

```

We develop a code in Python program for this algorithm, see Listing 2.1 at the end of this section.

Example 2.3.3. Firstly we totally color red the simplicial complex K shows in the left figure. We have three famous vertices $\{v_4, v_5, v_6\}$, we pick v_6 , next we totally color green all maximal contains v_6 (middle figure.) Now through the simplex $v_1v_4v_5$, the vertex v_1 is red and the edge v_4v_5 is green, so $v_1v_4v_5 \in M_{v_6}$, so we can extend greenness to this simplex as we shown in the right figure.



Figura 2.3: Strong collapse algorithm, part 1.



Figura 2.4: Strong collapse algorithm, part 2.

Now we do not have more red vertices, so we redefine M_{v_6} which is empty now, and we terminate the iteration of U_0 which represented in left figure. We redefine $S(K)$ and redefine K to be the complex spanned by the current red triangles $v_1v_2v_4, v_1v_5v_3$, which shows in the middle figure. We repeat again with the famous vertex v_1 to generate the cover set U_1 shown in the right figure.

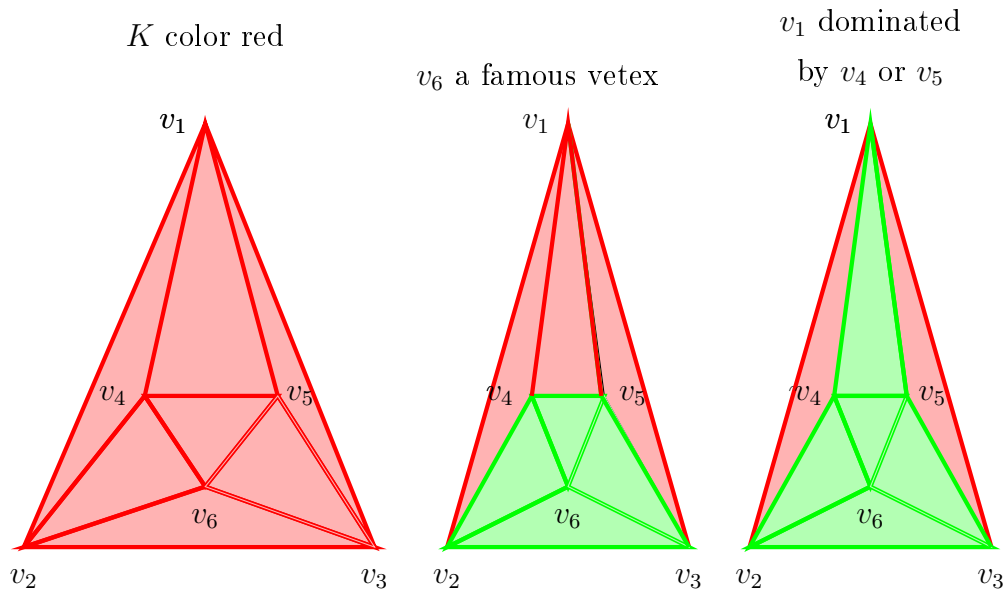
This example is a famous example showing that the complex is collapsible but not strong collapsible so $gscat(K) > 0$. Using the algorithm we have that $i = 1$, so $gscat \leq 1$, hence $gscat(K) = 1$.

Example 2.3.4. We apply the previous example with Python, where the program pick up v_4 as the first famous vertex instead of v_6 , and we also have $gscat(K) = 1$, see Listing 2.2.

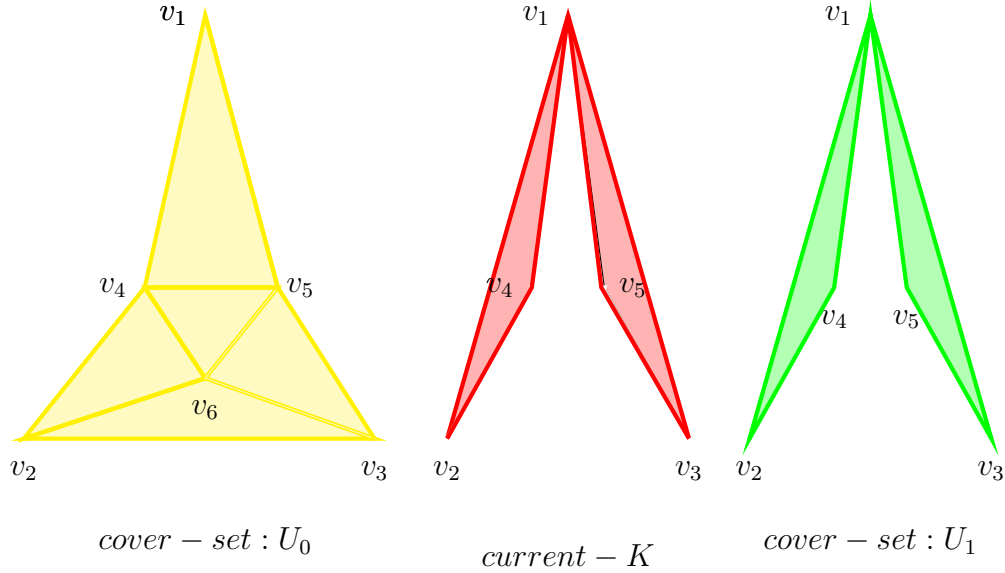
Proposition 2.3.5. The algorithm gives us the results as we expected.

Proof. First we will proof that $\bigcup U = K$, let $\sigma \in K$, the algorithm terminate only if all simplex change its color from red, so there exist $U \in \mathcal{U}$ such that $\sigma \in U$, done.

Now, we want to show that every $U_i \in \mathcal{U}$ are strong collapsible to a point.

In Line 7, any vertex v' belong to those maximals is dominated by the vertex v , since any maximal contains v' is also contain v (all current green simplices is actually represent a cone with apex v).

Going into Line 9. If $M_v = \phi$, we end the first iteration and we are done with a strong collapsible subcomplex U_0 .

Otherwise, we strong expansion U_0 with some red vertex w and a red simplex σ , the green proper face $\sigma - w$ is currently equal to $Lk(w)$.

And since $\sigma - w$ is a simplex in U_0 so it is represented a cone where some apex $w' \in \sigma - w$. So $Lk(w) = \sigma - w$ is a cone, so w dominated by the apex vertex w' . We create an elementary strongly expansion and we add the simplex σ to U_0 .

We repeat this strong expansion process until $M_v = \phi$, and here we finish the first iteration to construct U_v , which is strong collapse to v when we reverse the expansion steps. And so on, for all U_i 's.

When we repeat a gain the While loop in Line 2, it dose not matter if the new famous vertex is red or yellow (mention on the previous step), i.e. the vertex v can color green several times but every maximal color green only once time (Line 17), and this help us to partition the set of maximal simplices, This will help to reduce the number of set in \mathcal{U} to predict better $gscat(K)$. \square

Algorithm [1]

```

1  %"Select a famous vertex"
2  def famousPoint(bases):
3      v_lst=[]
4      for group in bases:
5          for v in group:
6              v_lst.append(v)
7      v_lst.sort()
8      #print(v_lst)
9      if len(v_lst)==0:
10         return None
11     wc = Counter(v_lst)
12     s = max(wc.values())
13     i = list(wc.values()).index(s)
14     print('To find the currently famous point:', wc)
15     return (list(wc.items())[i][0])
16
17 def cover(M):
18     K= list(M)
19     Gset=list()
20     GPoints=list()
21     i=0
22     while K!=[]:
23         Gset=list()
24         print("The current maximals are:",K)
25         F=famousPoint(K)
26         print('The famous point number',i,'is:',F)
27         if F != None:
28             #for item in points:
29             for item in K.copy():
30                 if K!=set():
31                     if F in item:
32                         Gset.append(tuple(item))
33                         K.remove(item)
34                         for greenPoint in tuple(item)

```

```

:
35         if not greenPoint in
GPoints:
36             GPoints.append(
greenPoint)
37             K=list(set(K)-set(Gset))
38             print("The new K is ",K)
39             print("Check for signle red point not in
Green Points: ",GPoints)
40             for item in K.copy():
41                 if K!=set():
42                     redItemRealLength=0
43                     redItemTargetLength=0
44                     for x in item:
45                         redItemTargetLength=len(item)
-1
46                     for g in GPoints:
47                         if (x in g):
48                             redItemRealLength=
redItemRealLength+1
49                             #print(x)
50
51                             redItemRealLength=
redItemRealLength+1
52                     if redItemRealLength==
redItemTargetLength:
53                         redItemRealLength=0
54                         Gset.append(tuple(item))
55                         for greenPoint in tuple(item)
:
56                             if not greenPoint in
GPoints:
57                                 GPoints.append(
greenPoint)
58                             if item in K:

```

```
59         K.remove(item)
60         #old set:
61         print('Currently base set after expansion ', '
is:',K)
62         print('The cover set number', i, 'related to
the vertex',
63         F, 'is:' ,Gset) #new set
64         i=i+1
65         print()
66         print('** So the cover contains of',i,'sets and
the upper bound
67         of the category "gscat" = ', i-1)
68         return
69
```

Listing 2.1: Algorithm 1. Strong collapse algorithm.

Code for Example 2.3.3

```

1 maximal_simplices = ['624', '236', '653', '456', '421', '
    145', '135']
2 cover(maximal_simplices)
3 "RESULT:"
4 The Current maximals are: ['624', '236', '653', '456'
    , '421', '145', '135']
5 To find the currently famous point: Counter({'4': 4,
    '5': 4, '6': 4, '1': 3, '2': 3, '3': 3})
6 The famous point number 0 is: 4
7 The new K is ['653', '236', '135']
8 Check for single red point not in Green Points:
9 ['6', '2', '4', '5', '1']
10 Currently base set after expansion is: K=['236', '135
    ']
11 The cover set number 0 related to the vertex 4 is:
12 [('6', '2', '4'), ('4', '5', '6'), ('4', '2', '1'),
13 ('1', '4', '5'), ('6', '5', '3')]
14
15 The maximals are: ['236', '135']
16 To find the currently famous point: Counter({'3': 2,
    '1': 1,
17 '2': 1, '5': 1, '6': 1})
18 The famous point number 1 is: 3
19 The new K is []
20 Check for single red point not in Green Points:
21 ['6', '2', '4', '5', '1', '3']
22 Currently base set after expansion is: []
23 The cover set number 1 related to the vertex 3 is:
24 [('2', '3', '6'), ('1', '3', '5')]
25
26 ** So the cover contains of 2 sets and
27 the upper bound of the category "gscat" = 1

```

Listing 2.2: Example: Partition the maximal set of simplicial complex

2.4. Edge Contraction

Removing edges or edge contractions usually used in computer graphics to simplify surfaces (which mean a 2-complex). During this processes the complex loses its non-trivial topological properties. So a local condition added to keep preserving the topological type during contract edges from the space, this mean that there is a homeomorphism connected between the underling space and the original space.

Definition 2.4.1. [10] *Let $K = (V, S)$ be a simplicial complexe, we say that we contract the edge $ab \in K$ if the vertex b is removed from the complex and the link of the vertex a is augmented with the link of the vertex b . Formally, we define the map f on the set of vertices V which maps b to a and acts as the identity function for all other vertices:*

$$f(x) = \begin{cases} a & x = b \\ x & \text{otherwise} \end{cases}$$

We then extend f to all simplices $\sigma = \{v_0, \dots, v_k\}$ of K , setting $f(\sigma) = \{f(v_0), \dots, f(v_k)\}$.

The edge contraction $ab \longrightarrow a$ is the operation that changes K to $K' = (V - b, S')$ where $S' = \{f(\sigma) : \sigma \in K\}$.

By construction, f is surjective and K' is a simplicial complex. Note that the edge contraction is well defined even when the edge ab does not belong to K .

An edge contraction does not always preserve the homotopy type, but if the *link condition* is verified, then it is a sufficient condition of preservation of the homotopy type.

Theorem 2.4.2. [4] (*LINK CONDITION THEOREM*). *Let K be a simplicial complex. The contraction of the edge $ab \in K$ preserves the homotopy type whenever $Lk(ab) = Lk(a) \cap Lk(b)$.*

Definition 2.4.3. *If the edge contraction verify the link condition we call this operation by edge collapse. A simplicial complex K is edge collapsible if there is a series of edge collapses start from K and end to a point.*

In [11] shows that if we have *flag [clique] complex* (which its simplices are define as a complete subgraph) then removing a dominated vertex does not affect the [flagness property] of the residual complex K' , but unfortunately removing an edge by contraction affect the flagness as we show in the next example.

We should rewrite the link condition, and suppose that $Lk(ab) \neq \phi$ to be suitable with some type of simplicial complexes as flag complex.

Example 2.4.4. *Assume the clique complex $K = \{a, b, c, d, ab, bc, cd, da\}$ which is not contractible complex. $Lk(a) = \{b, d\}$, $Lk(b) = \{a, c\}$ and*

$$Lk(ab) = \phi = Lk(a) \cap Lk(b).$$

But if we contract the edge ab we will get the triangle $K' = \{a, c, d, ac, cd, da\}$ which is not clique complex. We should add the simplex $\{abc\}$ to the residual complex K' to keep the "flagness", but this addition generate a contractible complex, so adding this triangle will not preserve the homotopy type.

Example 2.4.5. *We can not edge collapse the Bing house (Figure 1.4), there is no edges satisfy the link condition.*

In the following example, we can elementary collapse an edge ab , but it is not necessary that we can also edge collapse ab .

Example 2.4.6. *We have the free face (abd, ab) so we can elementary collapse the edge ab . But $c \in LK(a) \cap LK(b)$ and $c \notin LK(ab)$, so we can not edge collapse ab .*



Figura 2.5: Collapse but not edge collapse.

Now we will state the following theorem which discuss the relation between strong collapse a vertex and edge collapse.

Theorem 2.4.7. *If we have a dominated vertices in a simplicial complex then, we can make an edge collapse.*

Proof. Suppose we have a simplicial complex K , and a vertex b dominated by a vertex a . First we will show that $Lk(a) \cap Lk(b) \subseteq Lk(ab)$, so let $\sigma \in Lk(a) \cap Lk(b)$, that's mean $a \cup \sigma \in K$, $b \cup \sigma \in K$ and $a, b \notin \sigma$. Let σ' be the maximal set containing $b \cup \sigma$, by dominated property a also belongs to σ' . So we have that $a \cup b \cup \sigma \in \sigma'$. Hence the face $a \cup b \cup \sigma$ belongs to the complex K with $ab \cap \sigma = \emptyset$. So $\sigma \in Lk(ab)$.

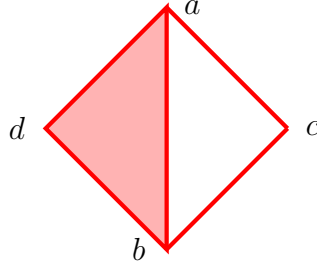
Finally take $\sigma \in Lk(ab)$, so $ab \cup \sigma \in K$ and the edge $ab \cap \sigma = \emptyset$ and then we have that the face $a \cup \sigma$ belongs to K and so on $\sigma \in Lk(a)$, with $a \notin \sigma$. Similarly for $\sigma \in Lk(b)$. So $Lk(ab) \subseteq Lk(a) \cap Lk(b)$ and the link condition is satisfied, we can edge collapse the edge ab . \square

The converse of this theorem is not true in general we will give a counter example showing this.

Example 2.4.8. *As shown in the graph below, we have a simplicial complex generates by the maximal sets $\{\{abd\}, \{bcd\}, \{ae\}\}$, with $Lk(a)$ generates by $\{bd, e\}$, $Lk(b)$ generates by $\{ad, cd\}$ and $Lk(ab) = \{d\} = Lk(a) \cap Lk(b)$, so we can edge collapse the edge ab .*

But we have the maximal simplex $\{ae\}$ contains a but not b , and the triangle

$\{bdc\}$ which is a maximal simplex containing b but not a , so neither a nor b dominated by the other.



Figura 2.6: Edge collapse but not strong collapse.

Later, in Example 3.2.2, we also will show that using the edge collapse process we can reduce the complex with keeping its homotopy type more than reducing it by the strong collapse process.

The following notation represent a consequence of elementary strong collapse and edge contraction, as follows:

Definition 2.4.9. [12] Let $K = (V, S)$ be a simplicial complex, with some vertex $v \in V$ and some k -simplex $\sigma \in S$ where $k = \dim(\sigma)$.

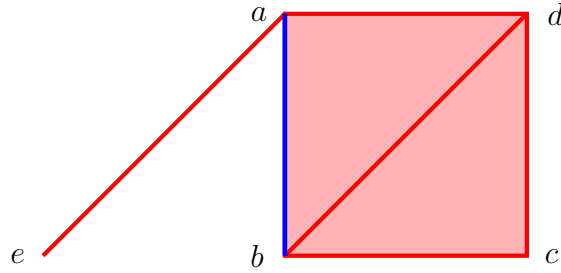
We say σ is dominated by the vertex v , if the link of σ is a cone in K , (i.e. $Lk(\sigma) = v * L$, for some sub-complex L).

Equivalently, every maximal simplices of K that contain σ also contain v .

If K' be the complex generate by removing the dominated k -simplex σ from K , indeed the simplices which contains σ also removing from K' .

Definition 2.4.10. ■ If σ is a simplex in K , denote $St_k(\sigma)$ to be the collection of simplices of K contain σ as a face.

■ The action of removing a dominated k -simplex σ is called an elementary k -collapse from K to $K \setminus St_k(\sigma)$.

- A simplicial complex is k -collapsible if it k -collapses to a point.
- A simplicial complex is non-evasive if it is k -collapsible for some $k \geq 0$.
- If the complex is not non-evasive, it will be called evasive.

By definitions, a 0-collapse is actually an elementary strong collapse.

Lemma 2.4.11. *Any elementary collapse of a k -simplex σ is a k -collapse.*

Proof. If we have an elementary collapse for a free face $\{\sigma, \tau\}$ in K , by definition σ is a proper face of τ and τ is the only maximal contains σ , so there exist a vertex $v \in V$ where $\tau = v \cup \sigma$. By the previous definition, σ is dominated by the vertex v . \square

Conversely, any k -collapse can be decomposed into a sequence of elementary collapses, as we will show next:

Theorem 2.4.12. [18] *Let K be a simplicial complex and let σ be a simplex of K . If σ is a dominated simplex, then there is a sequence of elementary collapses from K to $K \setminus St_K(\sigma)$*

Hence, by Theorem 2.1.4 there is strong deformation retraction between $|K|$ and $|K \setminus St_K(\sigma)|$.

So a non-evasive complex is collapsible.

Lemma 2.4.13. *A 1-collapse is edge collapse.*

The proof of this lemma is similar to the proof in Theorem 2.4.7. The converse is not true. For example, in the complex spanned by $\{abc, abd\}$, we can edge collapse ab since $Lk(ab) = \{c, d\} = Lk(a) \cap Lk(b)$.

But we cannot 1-collapse the simplex ab , since $Lk(ab)$ is not a cone.

2.5. Edge collapse Algorithm

Algorithm 2: Edge collapse algorithm [Functions part.]

Data: A non empty simplicial complex

```

1 Function StrongCollapse(RedMax, GrnSim):
2   GrV = {all green vertices belongs to green simplices}
3   for ( v in GrnV ) {
4     Conev = { $\delta$  :  $\delta$  red maximal simplex contains v }
5     for ( Conev! =  $\phi$  ) {
6       Pick  $\delta \in Cone_v$ 
7       if  $\delta$  contains unique green face which is v then
8         Color totally green  $\delta$ 
9         GrnSim = GrnSim  $\cup$  Conev
10        RedMax = RedMax - Conev /* if conev is a maximal
11                               */
12        else
13          Conev = {  $\partial(\delta)$  :  $\delta$  in Conev } /* all boundary for all
14                               simplices in Conev */
15          = all proper faces for every  $\delta \in Cone_v$ 
16        end
17      }
18    }
19  return RedMax, GrnSim

```

=====

```

Function EdgeCollapse(RedMax, GrnSim):
19 for (  $\delta$  in RedMax ) {
20   RdEdg = {ab: ab a red edge in  $\delta$ },
21   while RdEdg! =  $\phi$  do
22     Pick one edge ab from RdEdg
23     if ab is not a maximal. And all: a, b,  $\delta - a$ ,  $\delta - b$  are green
24     then
25       Color  $\delta$  totally green
26       RedMax = RedMax -  $\delta$ 
27       GrnSim = GrnSim +  $\delta$  break While
28     else
29       RdEdg = RdEdg - ab
30     end
31   end
32 }
33 return RedMax, GrnSim

```

Algorithm 3: Edge collapse algorithm [Main algorithm].

Data: A non empty simplicial complex $K = (V(K), S(K))$.

```

33 Set  $\mathcal{U} = \phi$ . // The cover set
34 Color red all the simplices in  $K$ ;
35 Initial  $i = 0$ .;
36 for (  $K \neq \phi$  ) {
37   Let  $RedMax$  be the set of all current red maximal simplices in  $K$ ;
38    $U_i = \phi$ ;
39    $FamV = \{v : v \text{ is a famous vertex over the current set } RedMax\}$ ;
40   Pick a random vertex  $v \in FamV$ ;
41   Color  $v$  blue.;
42   Color green all maximal set containing  $v$  with all their faces.;
43   Set  $U_v = \{\text{current green simplices}\}$ ;
44   Set  $GrnSim = \{\text{all the current green simplices with all their}$ 
      faces} /* all green compinations */
45   Function StrongCollapse(RMax, GrnSim) ;
46   Function EdgeCollapse(RMax, GrnSim)
47   Add all new green simplex to  $U_i$ ;
48   Color every simplex in  $U_i$  black and turn off green;
49    $\mathcal{U} = \mathcal{U} \cup U_i$  ;
50    $S(K) = S(K) - S(U_i)$ . /* the rest of red simplices
       $RMax = RMax - U_i$  */
51    $K$  spanned by the new set of simplices  $S(K)$ .;
52    $i = i + 1$ ;
      /* Go to line 36 */
}

```

Result: \mathcal{U} cover K and partition the maximal simplex, such that each $U_i \in \mathcal{U}$ is an edge collapsible sub-complex.

```

53 Print( $\mathcal{U}$  );
54 Print(  $Ecat(K) \leq i$  )

```

In this section, first we will state *Ecat* definition related to edge collapse concept, on the way of *gscat* definition. Then we will create an algorithm to determine an upper bound to *Ecat* by partition the maximal simplices of the complex to generate edge collapsible subcomplexes.

Through this algorithm, we provide another strategy to determine dominated vertices, differ than the previous strategy of Strong collapse algorithm in Section 3.

Definition 2.5.1. *Let K be a simplicial complex. The simplicial edge category $Ecat(K)$ is the least integer $m \geq 0$ such that K can be covered by $m + 1$ edge collapsible subcomplexes.*

For instance, K is edge collapsible if and only if $Ecat(K) = 0$.

This algorithm coded using Python program, as we will show at the end of this section.

In the algorithm, we denote $i = |\mathcal{U}| - 1$, which represent an upper bound of the of the category $Ecat(K)$.

Next we will state the following example to explain the algorithm steps and introduce its proof.

Example 2.5.2. *Suppose we have the simplicial complex represented in the following figure, first of all we color red all simplices as shown.*



Figura 2.7: Edge collapse algorithm, part 1.

We have here a unique famous vertices which is v , color it blue. Next we will add more simplices and vertices whose can strong or edge collapse to this point v . This will be the first edge collapsible cover set, denote U_v .

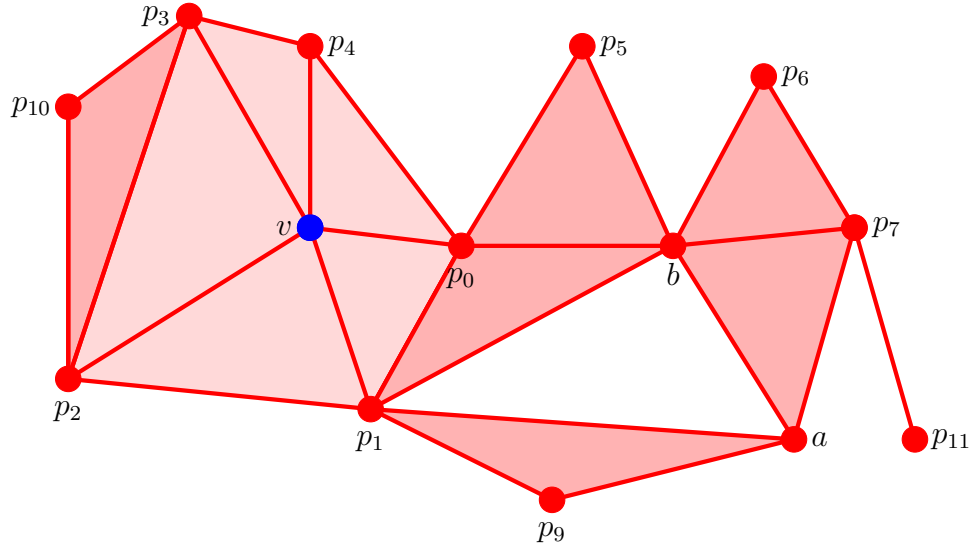

Figura 2.8: Edge collapse algorithm, part 2.

In figure 2.8, we color green all maximal simplices contains v , add all those simplices to the cover set U_v .

Next, the idea is to extend this U_v , by making elementary strong expansion (the converse of strong collapse).

This will happen through the currently green points $\{p_0, p_1, p_2, p_3, p_4\}$ by adding all red cones which have a unique green face which is one of these vertices, those vertices will represent the apex for the cones, For example:

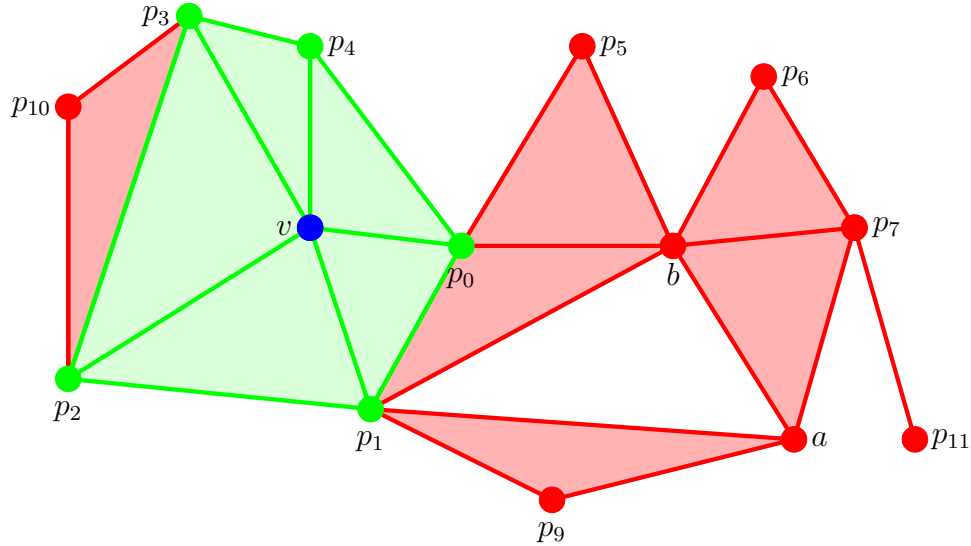
For the point p_0 it can be an apex for the red triangle $\{p_0, p_5, b\}$, but we cannot extend through the triangle $\{p_0, p_1, b\}$ since it is include another green face the edge $\{p_0, p_1\}$.

Similarly, we extend U_v through the green vertex p_1 by adding the cone $\{p_1, p_9, a\}$. And through p_2 to the cone $\{p_2, p_{10}\}$.



Figura 2.9: Edge collapse algorithm, part 3.

After determine all such cones, now color green all those cones and add them to U_v , so we have the Figure 2.9.

Note the red cones should be red (all its faces are red except the green apex), so we will be sure that this adding satisfies the strong collapse condition and we avoid having holes.

Now we will repeat this step (Line 3) over the new green points to extend U_v by strong expansions as the following Figure 2.10 shows. where we extend through the red cone $\{b, p_6, p_7\}$ with a green apex b .

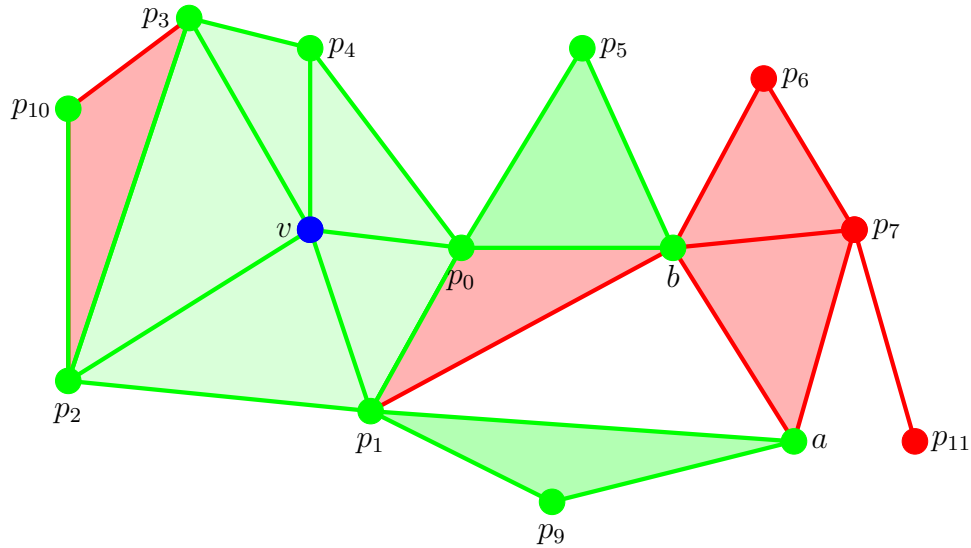

Figura 2.10: Edge collapse algorithm, part 4.

After color green the triangle, $\{b, p_6, p_7\}$, we repeat Line 3, to extend U_v by strong expansion the green point p_7 to the cone $\{p_7, p_{11}\}$.

Now we can not extend any more the subcomplex U_v (the green simplices in Figure 2.10) by strong expansions process, so we will move to *EdgeCollapse* function. Here we will extend U_v by edge expansions, as follows:

We pick a red edge ab contains in a red maximal δ such that $a, b, \delta - a, \delta - b$ all are green, those conditions agrees with the Link condition. The red edge bp_1 together with the red simplex bp_0p_1 are the only simplices satisfies the conditions, we color both green. And we have the Figure 2.11.

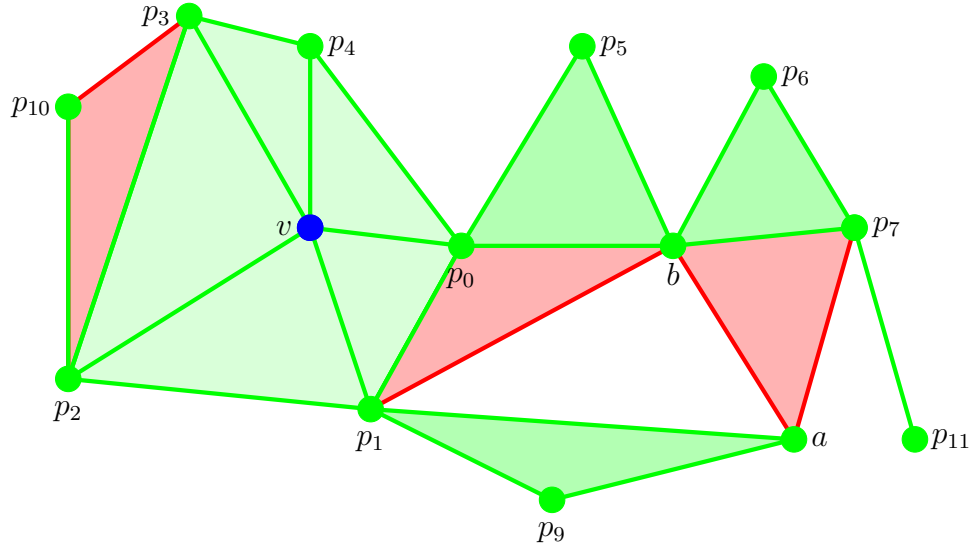
Here we finish the first iteration related to the first famous vertex, we color black all greens simplices and we perform the first cover set $U_0 \in \mathcal{U}$.



Figura 2.11: Edge collapse algorithm, part 5.

Following the conditions in *EdgeCollapse*, we can not extend through the red edge ab nor the edge ap_7 this avoids us to include the hole in the first cover set U_i , we explain this as follows:

During elementary edge collapse we contract only one edge each time, So adding the triangle abp_7 [where we will add two red edge] is not an elementary edge expansion.

Also in the currently green complex in Figure 2.11, if we want to add the edge ab with the triangle abp_7 .

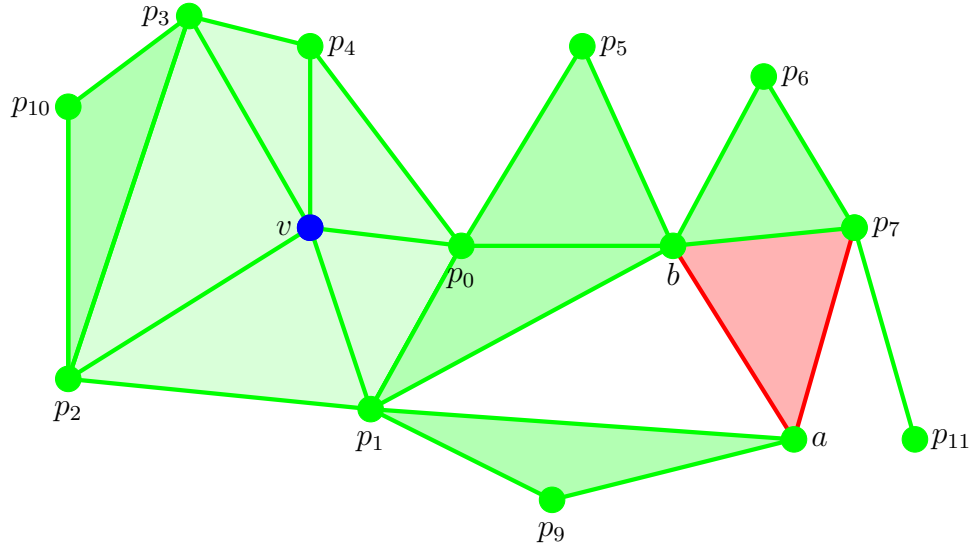
$lk(a)$ spanned by $\{p_1p_9, bp_7\}$, and $Lk(b)$ spanned by $\{p_0p_1, p_0p_5, p_6p_7, ap_7\}$, the intersection $Lk(a) \cap Lk(b) = \{p_1, p_7\}$ but $p_1 \notin Lk(ab)$.

We repeat again the iteration on the currently red complex to perform U_2 which is the triangle abp_7 . next we terminate the algorithm since no more red simplices exist.

Note that from the algorithm $Ecat(K) \leq 1$. And we can not edge collapse any of ab, ap_1, bp_1 and we have a hole so $Ecat(K) \neq 0$, so $Ecat(K) = 1$.

We compute the cover set of this example using the code in Python program as following:

```

1  ### input ###
2  [['v', 'p0', 'p1'], ['v', 'p1', 'p2'], ['v', 'p2', 'p3'], ['v', 'p3', 'p4'], ['v', 'p4', 'p0'], ['p0', 'p1', 'b'], ['p0', 'p5', 'b'], ['b', 'p6', 'p7'], ['b', 'p7', 'a'], ['p2', 'p10', 'p3'], ['p1', 'p9', 'a'], ['p7', 'p11']]
3  ### cover set number 1: ###
4  {'famous': 'v',
5   'set': [['v', 'p0', 'p1'],
6           ['v', 'p1', 'p2'],
7           ['v', 'p2', 'p3'],
8           ['v', 'p3', 'p4'],
9           ['v', 'p4', 'p0'],
10          ['p0', 'p5', 'b'],
11          ['p1', 'p9', 'a'],
12          ['b', 'p6', 'p7'],
13          ['p7', 'p11'],
14          ['p2', 'p10'],
15          ['p0', 'p1', 'b'],
16          ['p2', 'p10', 'p3']]}
17 ### cover set number 2: ###
18 {'famous': 'b', 'set': [['b', 'p7', 'a']]}
19
20 The maximals can partition into [2] edge-collapsible
    sets
21 gscat <= 1:

```

Listing 2.3: Edge collapse Algorithm. Example 1

Proposition 2.5.3. *The algorithm gives us the results as we expected.*

Proof. First we will proof that $\bigcup U = K$, let $\sigma \in K$, the algorithm terminate only if all simplex change its color from red to black so there exist $U \in \mathcal{U}$ such

that $\sigma \in U$, done.

Now by induction we want to show that every $U \in \mathcal{U}$ is edge collapsible to a point.

We start from the famous blue vertex v , let $\{\sigma_1, \sigma_2, \dots, \sigma_r\}$ be all maximal simplices containing v . For any vertex w in these σ 's, all maximal contain w also contain v , So w dominated by v . And by Theorem 2.4.7 we can collapse the edge vw . So all the subcomplex generated by $\{\sigma_1, \sigma_2, \dots, \sigma_r\}$ can edge collapsible to the blue point.

Similarly, in the Function **StrongCollapse**, we add cones to the currently complex, the apex of these cones is a green point so any red point belongs to these new cones is dominated by this green vertex (apex), so this process represents strong expansions, and hence edge expansions (The reverse of edge collapse). We repeat this For loop -searching for cones could be edge collapsed - until we add all possible cones, we start with cones of the highest dimension (maximals), and then we check all cones with the lower dimensions (proper faces of the previous cones) as shown in Line 11.

Secondly, In Function **EdgeCollapse**, we construct edge expansions as follows: We want to proof that the Link condition is satisfied through this Function, let K' be the current simplicial complex (the green simplices), pick a red edge ab belongs to a red maximal σ , which satisfies that that $\{a, b, \sigma - a, \sigma - b\} \in K'$ (they are green).

Claim, the edge ab satisfies the link condition

$$Lk(a) \cap Lk(b) = Lk(ab)$$

Remember K' is strong\ edge collapsible to the point v . Then we can strong\ edge expand v to a sub-complex K'' of K' where $K'' = \{a, b, \sigma - a, \sigma - b\}$.

Then we add the red simplices σ and ab to K'' . So, we have $Lk(a) \cap Lk(b) = \{\sigma - \{a, b\}\} = Lk(ab)$. Hence, ab satisfies the link condition.

$$K' \searrow \searrow \{v\} \nearrow \nearrow K'' = \{a, b, \sigma - a, \sigma - b\} \nearrow \nearrow \{\sigma\}$$

Repeat this step to add all possible edges whose satisfies the link condition. In this Function, we add the condition that ab is not maximal to avoid having the complex $K'' = \{a, b\}$ which is not connected and not collapsible, we also avoid the case $Lk(a) \cap Lk(b) = \emptyset$.

□

Example 2.5.4. Here, we will apply the algorithm for the Example 1.1.11. Recall this complex is not strong collapsible.

```

1  ### input ###
2  [['6', '5', '1'], ['5', '3', '1'], ['3', '2', '1'],
3   ['2', '6', '1'], ['4', '3', '2'], ['4', '6', '2'],
4   ['5', '4', '6']]
5  ### cover set number 1: ###
6  {'famous': '6',
7   'set': [['6', '5', '1'],
8           ['2', '6', '1'],
9           ['4', '6', '2'],
10          ['5', '4', '6'],
11          ['4', '3'],
12          ['4', '3', '2']]}
13 ### cover set number 2: ###
14 {'famous': '3', 'set': [['5', '3', '1'], ['3', '2', '1']]}
15 ### The maximals can partition into [2] edge-
16    collapsible sets ###
17 ### gscat <= 1: ###

```

Listing 2.4: Edge collapse Algorithm. Example 2

Remark 2.5.5. We state two different algorithm to predict the strong expansion, In Strong collapse algorithm each time we add one red vertex which dominated with v . In Edge collapse algorithm (the **StrongCollapse** function) we strat with a green vertex v , then add many red vertices in one step such that all this vertices belongs to a cone with apex v , and so dominated by v .

Since the complex induced by the family of maximal simplices, it follows that it will take at most the number of maximals iterations of the algorithms to find our cover and terminate.

Future work, state an algorithm for collapsible cover "free face".

Partition the maximal set of simplicial complex into edge collapsible sub-complexes Algorithm 2.

This code developed by IslamTaha-0X [1]

```

1
2 from collections import Counter
3 from itertools import combinations
4 from pprint import pprint
5
6  %"Select a famous vertex"
7 def get_famous_point(data):
8     list_of_points = [point for inner_list in data
9     for point in inner_list]
10    return Counter(list_of_points).most_common()
11    [0][0]
12
13 %"To get all maximal simplices contains the famous
14 vertex"
15 def get_green_list_of_lists(point, data):
16     green_list_of_lists = [inner_list for inner_list
17     in data if point in inner_list]
18     return green_list_of_lists
19
20 %"The set of all currently green points"
21 def convert_green_list_of_lists_to_set(
22     green_list_of_lists):
23     set_of_green_points = list(set([point for
24     inner_list in green_list_of_lists for point in
25     inner_list]))
26     return set_of_green_points
27
28 %"Search for green points"
29 def check_unique_green(set_of_green_points ,

```

```
red_list_of_lists_with_green):
26     green_unique_list_of_lists = []
27
28     for inner_list in red_list_of_lists_with_green:
29         counter = 0
30
31         if len(inner_list) == 1:
32             if inner_list[0] not in
set_of_green_points:
33                 counter = 1
34             else:
35                 for point in set_of_green_points:
36                     if point in inner_list:
37                         counter += 1
38
39             if counter == 1:
40                 green_unique_list_of_lists.append(
inner_list)
41
42     return green_unique_list_of_lists
43
44
45 % "To redefine the green sets and red sets"
46 def update_lists(green_unique_list_of_lists ,
green_list_of_lists , red_list_of_lists):
47     for _list in green_unique_list_of_lists:
48         green_list_of_lists.append(_list)
49         red_list_of_lists.remove(_list)
50
51     for inner_list in list(red_list_of_lists):
52         if not has_red_point(inner_list ,
green_list_of_lists):
53             red_list_of_lists.remove(inner_list)
54
55     return green_list_of_lists , red_list_of_lists
```

```
56
57
58 %"To check if there is a red point belongs to a
    spesific simplex"
59 def has_red_point(check_list, g_list_of_lists):
60     for point in check_list:
61         if point not in
            convert_green_list_of_lists_to_set(g_list_of_lists)
        :
62             return True
63     else:
64         return False
65
66
67 %"To get all faces in a specific simplex"
68 def get_all_combinations(list_of_lists):
69     tmp = []
70     for r_list in list_of_lists:
71         if len(r_list):
72             _tmp = [list(combination) for combination
                in combinations(r_list, len(r_list)-1)]
73             if _tmp not in tmp:
74                 tmp.extend(_tmp)
75
76     return tmp
77
78
79
80 def remove_duplicate(list_of_lists):
81     tmp = []
82     for _list in list_of_lists:
83         if _list not in tmp:
84             tmp.append(_list)
85     return tmp
```

```
87
88
89 def logic(point, green, red):
90     if green:
91         set_of_unique_points =
convert_green_list_of_lists_to_set(green)
92     else:
93         set_of_unique_points = [point]
94
95     red_with_green_points = get_green_list_of_lists(
point, red)
96     g_unique_list_of_lists = check_unique_green(
set_of_unique_points, red_with_green_points)
97     if len(g_unique_list_of_lists):
98         update_lists(g_unique_list_of_lists, green,
red)
99
100
101     #####
102 %"Here we start the main code using the previous
functions,"
103 %"where we will determine the famous point with its
simplices,"
104 %"then we operate the strong expansion"
105 print('### input ### ')
106 print(inputs)
107 results = []
108
109 while True:
110     g_list_of_lists = []
111     r_list_of_lists = list(inputs)
112
113     # init
114     famous_point = get_famous_point(inputs)
115     logic(famous_point, g_list_of_lists,
```

```

r_list_of_lists)
116
117     while r_list_of_lists:
118         has_been_checked = []
119         while sorted(has_been_checked) != sorted(
convert_green_list_of_lists_to_set(g_list_of_lists)
):
120             # while r_list_of_lists:
121                 check_list =
convert_green_list_of_lists_to_set(g_list_of_lists)
122                 for _point in check_list:
123                     if _point not in has_been_checked:
124                         logic(_point, g_list_of_lists,
r_list_of_lists)
125                         has_been_checked.append(_point)
126
127                 tmp = []
128                 for r_list in r_list_of_lists:
129                     if len(r_list):
130                         tmp.extend([list(combination) for
combination in combinations(r_list, len(r_list) -
1)])
131                 r_list_of_lists = tmp
132
133
134     r_list_of_lists = [inner_list for inner_list in
inputs if inner_list not in g_list_of_lists]
135     # print(r_list_of_lists)
136
137     no_way_to_move_to_g = []
138
139
140
141
142

```

```

143
144 %"Here is the second part of the main code where we
    operate all possible edge expansions"
145
146     while r_list_of_lists:
147         _g_compinations = get_all_combinations(
g_list_of_lists)
148         _tmp = g_list_of_lists + _g_compinations
149         g_list_of_lists_compinations =
remove_duplicate(_tmp)
150
151         for r_list in list(r_list_of_lists):
152             if len(r_list) <= 2:
153                 no_way_to_move_to_g.append(r_list)
154                 r_list_of_lists.remove(r_list)
155                 break
156             g_points =
convert_green_list_of_lists_to_set(g_list_of_lists)
157             exiting_g_points = []
158             for g_point in g_points:
159                 if g_point in r_list:
160                     exiting_g_points.append(g_point)
161
162             if len(exiting_g_points) < 2: # this
r_list doesnt have two g points
163                 no_way_to_move_to_g.append(r_list)
164                 r_list_of_lists.remove(r_list)
165
166             else:
167                 for g_vector in [list(combination)
for combination in combinations(exiting_g_points,
2)]:
168                     if g_vector in inputs:
169                         no_way_to_move_to_g.append(
r_list)

```

```

170         r_list_of_lists.remove(r_list
171     )
172         break
173     else:
174         tmp_r_list_0 = [point for
point in r_list if point != g_vector[0]]
175         tmp_r_list_1 = [point for
point in r_list if point != g_vector[1]]
176
177         if (tmp_r_list_0 in
g_list_of_lists_compinations) and (tmp_r_list_1 in
g_list_of_lists_compinations):
178             g_list_of_lists.append(
r_list)
179             r_list_of_lists.remove(
r_list)
180             break
181         else: # no vector can solve it
no_way_to_move_to_g.append(r_list
182     )
183
184         r_list_of_lists.remove(r_list)
185
186     results.append(
187         {"set": g_list_of_lists,
188         "famous": famous_point}
189     )
190
191     inputs = list(no_way_to_move_to_g)
192     if len(no_way_to_move_to_g) == 0:
193         break
194
195 for index in range(0, len(results)):
196     print(f"### cover set number {index+1}: ### ")
pprint(results[index])

```

```
197
198 print(f"### The maximals can partition into [{index
199     +1}]
200     edge-collapsible sets ### ")
201 print(f"### gscat <= {index}: ### ")
```

Listing 2.5: Algorithm 2. Edge collapse algorithm

One can find this code in GitHub. The link:

<https://gist.github.com/0xIslamTaha/3379086c2f870b29adf953bb16c6b774>

Chapter 3

Matroid

3.1. Preliminaries

Mathematical systems called matroids were introduced and named by H. Whitney [51] in 1935, as an abstract generalization of matrices. In this part we want to show that in the case of matroid, the two definition of elementary collapse and strong collapse turn out to be equivalent, more over it is sufficient to find one dominated vertex to collapse all the matroid to a point. Also we show that every matroid is either a core or strong collapsible to a point. We will assume here that all simplicial complexes are finite and connected (the zero homology group equal one).

Definition 3.1.1. [21] *A finite matroid is a pair $M = (V, \mathcal{I})$ of a finite set V and $\mathcal{I} \subseteq 2^V$ is a non void simplicial complex satisfying the following property which is called the Exchange property:*

If $I_1, I_2 \in \mathcal{I}$ and $|I_2| < |I_1|$, then $\exists i \in I_1 \setminus I_2$ such that $i \cup I_2 \in \mathcal{I}$.

For a matroid $M = (V, \mathcal{I})$,

$V(M) := V$ is called the ground set of M ,

The sets in $\mathcal{I}(M) := \mathcal{I}$ is called an independent sets of M ,

Every maximal independent set $B \in \mathcal{I}$ called base and the bases set denoted by $\mathcal{B}(M)$.



We call $A \subseteq V$ submatroid of M , if we can defined a matroid on A by considering a subset of A to be independent if and only if it is independent of M .

The Exchange property defined equivalently in [40] as the following:

If $I_1, I_2 \in \mathcal{I}$ and $|I_1| = |I_2| + 1$, then $\exists i \in I_1 \setminus I_2$ such that $i \cup I_2 \in \mathcal{I}$.

Every matroid is *pure* that's mean, every maximal set is maximum, (i.e. all the maximals set have the same number of vertices). If we have the set of maximal sets $\mathcal{B}(M)$ we can generate the matroid M by adding all faces for each set in $\mathcal{B}(M)$.

Example 3.1.2. Let E be a finite set and k a natural number. One may define a matroid on E by taking every k -element subset of E to be a basis. This is known as the uniform matroid.

For more examples, using SageMath [an open-source mathematics software system], see Listing 3.1

Theorem 3.1.3. Let $\mathcal{B}(M) = \{F_i : i \in \Delta\}$ be the base for a matroid M . If $\bigcap_{\mathcal{B}(M)} F_i = \phi$, then M has no dominated vertices, that's means M is a core.

Proof. Assume to contrary that there is two vertices v and w such that v is dominated by w , so by definition any maximal set contains v also contains w . We will construct a maximal (maximum) set containing v but not w . Since $w \notin \bigcap_{\mathcal{B}(M)} F_i$, there exist a maximum set $F = \{f_\alpha : \alpha \in \Gamma\}$ such that $w \notin F$ so also $v \notin F$, and $|v| < |F|$ by exchange property there exist f rename by $f_1 \in F \setminus \{v\}$ such that $\{vf_1\} \in M$. Now repeat with the set $\{vf_1\}$ to construct the set $\{vf_1f_2\}$ and continue to get the set $\{vf_1f_2\dots f_{n-1}\}$ with $|\{vf_1f_2\dots f_{n-1}\}| = |F|$ which is a maximum set containing v but not w since $w \neq f_\alpha \forall \alpha$. So v is not dominated by w and hence there is no dominated vertices and M is a core. \square

We need the following lemma to show that elementary strong collapse dose not affect on the structure of a matroid.

Lemma 3.1.4. Matroids are closed under deletion a point from independent sets.

Proof. Let $M = (V, \mathcal{I})$ be a matroid, choose a vertex $e \in V$ belong to some independent set in \mathcal{I} and let \hat{M} be the simplicial complex generate by the deletion $M \setminus e$. For any $\hat{I}, \hat{J} \in \hat{M}$ such that $|\hat{I}| = |\hat{J}| + 1$, they are represented by two sets $I, J \in M$. Now we have four cases:

- If $e \in I$ and $e \in J$, then $|I| = |e \cup \hat{I}| = |e \cup \hat{J}| + 1 = |J| + 1$, so there exist $i \in I \setminus J$ such that $i \cup J \in M$. Note that this $i \neq e$ (since $i \in I \setminus J$). So $i \in \hat{I} \setminus \hat{J}$ and $i \cup \hat{J} \in \hat{M}$
- If $e \in I$ and $e \notin J$, then $|I| = |e \cup \hat{I}| = |e \cup \hat{J}| + 1 = |e \cup J| + 1 = |J| + 2$, so $|I \setminus e| = |J| + 1$, now $\exists i \in \{I \setminus e\} \setminus J$ such that $i \cup J \in M$, since $i \neq e$, so $i \in \hat{I} \setminus \hat{J}$ and $i \cup \hat{J} \in \hat{M}$
- If $e \notin I$ and $e \in J$, then $|I| = |e \cup \hat{I}| - 1 = |e \cup \hat{J}| = |J|$, but $|I| = |J \setminus e| + 1$, so $\exists i \in I \setminus \{J \setminus e\}$ such that $i \cup J \setminus e \in M$, and $i \neq e$, so $i \in \hat{I} \setminus \hat{J}$ and $i \cup \hat{J} \in \hat{M}$
- The last case where $I = \hat{I}, J = \hat{J}$ is trivial.

So the exchange property satisfied and \hat{M} is a matroid. \square

So, if we strong collapse a matroid $M \searrow \searrow M_1 \searrow \searrow \cdots \searrow \searrow M_r$, all these subcomplexs whose generate by deleting a dominated vertices are submatroids. unfortunately this is not true in the case of usual collapse as we will discuss in Example 3.1.6. Now we can construct the following equivalent statement.

Theorem 3.1.5. *Let M be a matroid with the base $\mathcal{B}(M) = \{F_i : i \in \Delta\}$ such that $|F_i| = n \forall i$, and let e be a vertex in $V(M)$, then the following statement are equivalent:*

- a. $e \in \bigcap_{i \in \Delta} F_i$.
- b. $M \searrow \searrow \{e\}$.
- c. $M \searrow \{e\}$.
- d. *There exist a free face.*

- e. *There exist a dominated vertices.*

So we conclude that every matroid is either a core or it is strong collapsible to a point. In part d. for any maximum F_i , we have the free face $\{F_i, F_i \setminus e\}$.

This Theorem has been developed in a code. See Listing 3.1, at the end of this section.

Proof. .

a. \Rightarrow b. Consider a.

Step 1, since M is pure and e belong to every base set (maximal), so any vertex $w \in M$ can be dominated by e , strong collapse M and delete w , we have $M \searrow \searrow M \setminus \{w\}$. Now by previous lemma $M \setminus \{w\}$ is also a matroid.

We have new set of maximals $\{F_i, i \in \Delta\} \subsetneq \mathcal{B}(M)$ with e in the intersection and $|F_i| = n$. Repeat to get a series of matroids generate by removing a dominated vertex from maximals belong to $\mathcal{B}(M)$. We stop when every set in the base \mathcal{B} is collapsed.

Step 2. Now we have a new matroid M^{n-1} with dimension = dimension(M) - 1 = $n - 1$ whose maxials (denote by P_j 's, $j \in J$) are proper faces of F_i 's.

Claim: $e \in \cap_J P_j$.

In the original matroid M , all proper faces of the F_i 's contains e except the proper faces $\{F_i \setminus e : i \in \Delta\}$. Fix i , $F_i \setminus e$ contains one of the dominated vertices which we already collapsed in step 1, so the dimension of $F_i \setminus e$ over the currently matroid M^{n-1} is $n-2$, so it is not a maximal in M^{n-1} , so $e \in \cap_J P_j$. Now repeat step 1 for the matroids with dimension $n - 1$.

Step 3. Repeat step 2 for each dimension $n, n-1, \dots, 0$. We have $M \searrow \searrow \{e\}$.

b. \Rightarrow c. Remark 2.2.7 shows that every strong collapsible complex is a collapsible complex.

a. \Rightarrow d. Now assume [d.] but not [a.], suppose there is a free face $\{\delta, \tau\}$ where τ is a maximal, so it is one of the maximums F_i 's and there exist a vertex e such that $\sigma = \tau - e$ and there is no other maximal contain σ . For any maximum $F \neq \tau$, $|F| = |\tau| = |\sigma| + 1$, by exchange property there exist $f \in F \setminus \sigma$ such that $f \cup \sigma \in M$ which is a maximum containing σ , so

$f \cup \sigma = \tau$ and $e = f \in F$. Since F is arbitrary, so $e \in \bigcap_i F_i$. So [d.] \Rightarrow [a.]

b. \Rightarrow e. Clear.

e. \Rightarrow a. By Theorem 3.1.3.

□

Unfortunately, removing a free face -in general- dose not generate a matroid -see the following example- But since the existence of a free face in a matroid (as a simplicial complex) yields to collapse the matroid to a single point which is also a matroid.

We can avoid this problem by using a series of elementary strong collapse instead of the elementary collapse so we will still having a matroid in each point deletion.

Example 3.1.6. *Assume the matroid generate by the base $\mathcal{B}(M) = \{\{123\}, \{145\}, \{124\}, \{135\}\}$. Note that $(\{145\}, \{45\})$ is a free face, if we apply the elementary collapse over this face we reproduce the simplicial complex $\{\{123\}, \{124\}, \{135\}\}$ which is not a matroid. But the intersection over $\mathcal{B}(M)$ is not empty, so using the proposition this matroid strong collapse to a point.*

Example 3.1.7. *The simplicial complex generates by $\mathcal{B}(M) = \{\{12\}, \{23\}, \{13\}\}$ is an example of a non collapsible matroid.*

The uniform matroid is collapsible when $k = |E|$ and otherwise it is a core.

Now we want to show how evasiness (Definition 2.4.10) affects if the complex is a matroid.

Proposition 3.1.8. *A matroid is evasive if and only if it is a core.*

Proof. If we have an evasive matroid then it is not k -collapsible for all k , choose $k = 0$, we get that the matroid is a core.

Now if we have a core matroid, by 3.1.5 it is also is not collapsible. Since if there exist any k -collapse, it can be decomposed into a sequence of elementary collapses, which is not exist in M , so we have an evasive matroid. □

```
1 We use a matroid package called {sage.matroids.
  advanced}
2
3 from sage.matroids.advanced import *
4 EmptyMatroid = BasisMatroid()
5 empty
6 #Matroid on 0 elements with 1 bases
7
8 "Now we can define a matroid using its bases [the
  maximal sets]"
9 "There is two ways:"
10 M0 = BasisMatroid(groundset='abcd', bases=['ab', 'ac'
  , 'ad', 'bc', 'bd', 'cd'])
11 M1 = Matroid(['ab', 'ac', 'ad', 'bc', 'bd', 'cd'])
12 M0 == M1
13 # True
14 sorted(M1.bases())
15 #[frozenset({'a', 'b'}),
16 # frozenset({'a', 'c'}),
17 # frozenset({'b', 'c'}),
18 # frozenset({'a', 'd'}),
19 # frozenset({'b', 'd'}),
20 # frozenset({'c', 'd'})]
21
22 "To count number of basis"
23 len(M1.bases())
24 # 6
25
26 "Here a famous example of matroid called {The uniform
  matroid}"
27 "For example: vertex set{1,2,3,4,5} and the base are
  all compinations of two elements"
28 M2 = BasisMatroid(matroids.Uniform(2, 5))
29 M2
30 #Matroid of rank 2 on 5 elements with 10 bases
```

```
31 sorted(M2.bases())
32 # [frozenset({0, 1}), frozenset({0, 2}),
33 #  frozenset({1, 2}), frozenset({0, 3}),
34 #  frozenset({1, 3}), frozenset({2, 3}),
35 #  frozenset({0, 4}), frozenset({1, 4}),
36 #  frozenset({2, 4}), frozenset({3, 4})]
```

Listing 3.1: Examples of matroids

In the following code, we will test if a given structure collection represent a matroid or not.

```

1 M3 = BasisMatroid(groundset='abcd', bases=['abc', '
    bcd'])
2 M3.is_valid()
3 # True
4
5 M4 = BasisMatroid(groundset='1234', bases=[12,24]) "
    not a matroid"
6 M4.is_valid()
7 # Errorr
8
9 sorted(M3.groundset())
10 #['a', 'b', 'c', 'd']
11
12 "This function return the intersection from a set of
    lists:"
13 def getIntersection(s):
14     i = set(s[0])
15     for x in s[1:]:
16         i = i & set(x)
17     return i
18
19
20 getIntersection(sorted(M3.bases()))
21 #{'b', 'c'}

```

Listing 3.2: Test a collection is a matroid

Algorithm for Theorem 3.1.5

```

1 After determine the intersection of all basis sets,
  we test:
2 If the intersection is not empty, then the matroid
  is strong collapsible.

```

```
3 If the intersection is empty, then the matroid is a
  core and there is no any vertices to collapse.
4
5 def Test(Mat):
6     if Mat.is_valid()== True:
7         s= sorted(Mat.bases())
8         print('This is a matroid')
9         if getIntersection(s)!= set():
10            print('The matroid is contractible')
11        else:
12            print('The matroid is not contractible
13            and it is a core')
14        else:
15            print('This is not a matroid')
16            return
17 Test(M1)
18 #This is a matroid
19 #The matroid is not contractible and it is a core
20
21 Test(M2)
22 #This is a matroid
23 #The matroid is not contractible and it is a core
24
25 Test(M3)
26 #This is a matroid
27 #The matroid is contractible
28
29 Test(M4)
30 #This is not a matroid.
```

Listing 3.3: Algorithm 3. Test if a matroid is a core

3.2. Edge collapse and Matroids

The class of matroid are closed under edge contraction as we show in the next proposition.

Proposition 3.2.1. *Contracting an edge from a matroid yields to a new matroid.*

Proof. Let M be a matroid, and \hat{M} be the matroid generates from M by contracting the edge ab to a point c . Assume $\hat{I}, \hat{J} \in \hat{M}$, $|\hat{I}| = |\hat{J}| + 1$, and let I and J be the original corresponding sets in M . The proof contains 4 cases, we will discuss one of them as an example.

If $c \notin \hat{I}$ and $c \in \hat{J}$. Firstly if both $a, b \in J$, so $|I| = |\hat{I}| = |\hat{J}| + 1 = |J| = |J \setminus a| + 1$, there exist $i \in I \setminus \{J \setminus a\}$ and $i \cup J \setminus a \in M$, since $b \in J \setminus a$ then $J \setminus a$ contract to \hat{J} , so $i \cup \hat{J} \in \hat{M}$.

Secondly, if only one of a, b , say a , belongs to J , so $|I| = |J| + 1$ and $\exists i \in I \setminus J$, $i \cup J \in M$, and so $i \cup \hat{J} \in \hat{M}$. \square

Now, we want state the following example shows that we can't include the edge collapse operation in Proposition 3.1.5 as we done with both collapse and strong collapse.

Also this example shows that, if we have a core matroid [there is no strong collapse], so we can reduce more the matroid [or simplicial complex] by an edge collapse.

Also the same simplicial complex shows that an edge collapse is unnecessary obtain an elementary collapse .

But [16] shows that, if we have an edge collapse, then we can structure a finite sequence of simplicial complexes between K and $K' = K \setminus ab$ such that for every two consecutive complexes obtained from the other by an elementary collapse or an elementary expansion (i.e, K, K' have the same homotopy type).

Example 3.2.2. *Suppose we have the simplicial complex showing in the left graph which generate by the maximal sets $\{a12, a23, a34, a14, b12, b23, b34, b14\}$*



Figura 3.1: Simplicial complex (matroid) can be edge collapsed but not collapse nor strong collapse.

Since every edge in the complex included in two triangles (maximal sets), so we can say that there is no free faces in this complex. Also we can check that there is no dominated vertices, since for every two vertices there exist two different maximal sets separates them.

We can easily concludes this from Theorem 3.1.5 since this simplicial complex is a matroid, where the intersection of all its base sets is empty, so by theorem 3.1.3 it is a core

But we can reduce this simplicial complex keeping preserve its homotopy type using the definition of edge collapse, $Lk(1) = \{a, b, 2, 4, a2, a4, b2, b4\}$, $Lk(2) = \{a, b, 1, 3, a1, a3, b1, b3\}$ and $Lk(12) = \{a, b\}$, we have that $Lk(12) = Lk(1) \cap Lk(2)$, so we can collapse the edge $\{12\}$ as shown in the right complex. Note that we can't edge collapse more edges from the reduce complex on the right figure.

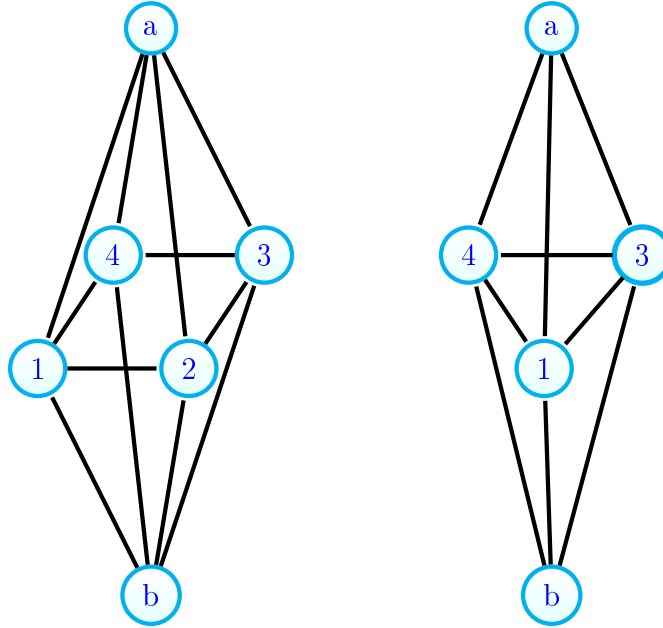
3.3. Algorithm: Partition of matroid's base

In this section, we want to partition the bases set of a matroid into family of subsets, each subset generates a new collapsible matroid, first we need the following theorems.

Theorem 3.3.1. *A pure simplicial complex with dimension n is a matroid if it satisfies the following:*

If F a maximal simplex and A any simplex such that $|A| = n - 1$, then $\exists i \in F \setminus A$ such that $i \cup A \in M$. where

that is, to determine if a pure simplicial complex is a matroid, its enough to check if the exchange property satisfies over all maximal simplices with $dim = n$ together with all of their proper faces with $dim = n - 1$.

Proof. Let S be a simplex with dimension $n - 1$ and S' be a simplex with dimension $n - 2$.

There exist a maximal F contains S as its proper face, we can write $F = s \cup S$ for some s .

Also, there exist a maximal F' contains S' as a face, and there exist a vertex $s' \in F'$ such that $s' \cup S' \in F'$ and hence $s' \cup S' \in K$. with dimension $n - 1$.

Now apply the hypothesis over F together with $s' \cup S'$, so there exist $f \in F \setminus \{s' \cup S'\}$ such that $f \cup s' \cup S' \in K$.

But $F = s \cup S$, if $f \in S$, done.

If not, then $f = s$, so $s \cup s' \cup S' \in K$, take the face $s \cup S'$ where its dimension is $n - 1$. Apply the hypothesis again over F and $s \cup S'$, we have that there exist a vertex $f' \in F \setminus \{s \cup S'\}$ and $f' \cup s \cup S' \in K$. Sure $f' \neq s$, so $f' \in S$, done.

So the exchange property is satisfied over all simplices of dimension $n - 1$ together with simplices of dimension $n - 2$.

We can complete for lower dimensions with the same way to show that the exchange property satisfied over the simplicial complex which is a matroid. \square

We will use this result to proof next theorem.

Theorem 3.3.2. *Let $M = (V, \mathcal{I})$ be a matroid with bases set \mathcal{B} , $e \in V$. Let $\mathcal{U}_e \subseteq \mathcal{B}$ be the set contains all maximal sets containing the vertex e , then \mathcal{U}_e represent a base of a new matroid.*

Proof. We can suppose that \mathcal{U}_e is a pure simplicial complex. Choose any maximal sets $I, J \in \mathcal{U}_e$ and let $\hat{J} = J|v$ for arbitrary vertex $v \in J$. We will show that the exchange property satisfied over all maximals together with all their proper faces.

First, if $e \in \hat{J}$, and since M is a matroid then $\exists i \in I \setminus \hat{J}$ such that $i \cup \hat{J} \in M$, but $e \in i \cup \hat{J}$ belongs to \mathcal{U}_e .

Second, if $e \notin \hat{J}$, but $e \in J$, then $v = e$ and we get $e \cup \hat{J} = J \in \mathcal{U}_e$. Now we apply Theorem 3.3.1 to prove that \mathcal{U}_e satisfy the exchange property. \square

Note that every \mathcal{U}_e represent a strong collapsible matroid by Theorem 3.1.5, so with this strategy we can cover the original matroid M by collapsible submatroids $\mathcal{U}_{e_1}, \mathcal{U}_{e_2}, \mathcal{U}_{e_3}, \dots$. To reduce the number of sets in this cover we can choose the first vertex e_1 to be a famous vertex, and so on.

Listing 15 shows how to determine the famous vertices of a matroid using Python program. After we pick this vertex from V , we start to build a collapsible submatroid starting from this vertex.

Algorithm 4: Edge collapse algorithm for matroids.

Data: A non empty matroid M with a base set $\mathcal{B}(M)$.

```

1 Set  $\mathcal{U} = \phi$ 
2 Set  $i = 0$ 
3 while  $\mathcal{B} \neq \phi$  do
4   For each vertex  $v$ , count its frequency over  $\mathcal{B}$  and denote the
   number by  $N_v$ .
5    $W = \{v : N_v \text{ is a maximum over the current base } \mathcal{B}\}$ .
6   if  $W \neq \phi$  then
7     Pick one vertex  $v \in W$ 
8      $U_v = \{I \in \mathcal{B} : v \in I\}$  /* The set  $U_v$  generates a submatroid */
9      $\mathcal{U} = \mathcal{U} + \{U_v\}$ 
10     $\mathcal{B} = \mathcal{B} - U_v$ 
11     $i=i+1$ 
12  end
13 end

```

Result: \mathcal{U} covers M and partition the base $\mathcal{B}(M)$, such that each $U_v \in \mathcal{U}$ is strongly collapsible submatroid to v .

```

14 Print( $\mathcal{U}$ )
15 Print(  $gscat(K) \leq i$  )

```

$i = |\mathcal{U}| - 1$ represent an upper bound for $gscat$.

This algorithm has been developed on Python program, See Listing 3.5 at the end of this section.

Proposition 3.3.3. *The algorithm gives us the results as we expected.*

Proof. We use Theorem 3.3.2 to show that every U_v represents a sub-matroid and we use Proposition 3.1.5 shows that any U_v obtains in the algorithm is strong collapsible. So we just need to show $\mathcal{U} = M$, so let $\sigma \in M$, there is a bases set in \mathcal{B} containing σ , but the algorithm terminate only if $\mathcal{B} = \phi$, so $\mathcal{U} = M$, that is \mathcal{U} covers M . \square

Example 3.3.4. *A coded example see Listing 3.6.*

Example 3.3.5. *Suppose we have the matroid stated in Example 3.2.2.*

Using the code - see Listing 3.7- the cover set of the matroid containing two

submatroids, and $gscat \leq 1$.

But we shown that this matroid is not strong collapsible so $gscat > 0$ and it is exactly equal 1.

Finding the famous point in the currently base.

```

1
2 from sage.matroids.advanced import *
3 from collections import Counter
4
5 "convert all bases data to single string to check the
   maximum occurrence of char and get the first one"
6
7 def famousPoints(L):
8     cs=""
9     for i in L:
10         for c in i:
11             cs+=cs.join(str(c))
12     print(cs)
13     if len(cs)==0:
14         return None
15     wc = Counter(cs)
16     s = max(wc.values())
17     i = list(wc.values()).index(s)
18     print(wc)
19     return (list(wc.items())[i][0])
20 #####
21
22 Matroid = BasisMatroid(groundset='abcd', bases=['abc'
23         , 'bcd'])
24 Matroid.is_valid()
25 #True
26 s= sorted(Matroid.bases())
27 points=famousPoints(s)
28 print(points)

```

```

28 #cbacdb
29 #Counter({'c': 2, 'b': 2, 'a': 1, 'd': 1})
30 #c
31 #####

```

Listing 3.4: Finding the famous points.

Algorithm 4

```

1 def cover(M):
2     "To test if this is a matroid or not?"
3     print(M.is_valid(), 'matroid')
4     print()
5     s= sorted(M.bases())
6     print('Matroid bases:', s)
7     print()
8     i=0
9     while s!=[]:
10        newS=set()
11        points=famousPoints(s)
12        print('The famous point number',i,'is:',
points)
13        if points != None:
14            "For item in points:"
15            for _s in s.copy():
16                if s!=set():
17                    if points in _s:
18                        "NewS[points] = newS.add(_s)"
19                        newS.add(tuple(_s))
20                        s.remove(_s)
21            "The old set:"
22            print('Currently base set after collapsing to
',points,'is:',s)
23            print('The cover set number', i, 'related to
the vertex',
24            points,'is:',newS) #new set
25            i=i+1

```

```

26         print()
27         print('*.* So the cover contains of',i,
28         'sets and the upper bound of the category "gscat"
        = ', i-1)
29         return

```

Listing 3.5: Algorithm 4. Partition of matroid base

Example 3.3.4

```

1 M1 = BasisMatroid(groundset='abcd', bases=['ab', 'ac'
      , 'ad', 'bc', 'bd', 'cd'])
2 cover(M1)
3
4 #RESULT:
5 True matroid
6
7 Matroid bases: [frozenset({'a', 'b'}), frozenset({'a'
      , 'c'}), frozenset({'b', 'c'}), frozenset({'a', 'd'
      }), frozenset({'d', 'b'}), frozenset({'d', 'c'})]
8
9 To find currently famous point: Counter({'a':3, 'b'
      :3, 'c':3, 'd':3})
10 The famous point number 0 is: a
11 Currently base set after collapsing to a is:
12 [frozenset({'b', 'c'}), frozenset({'d', 'b'}),
      frozenset({'d', 'c'})]
13 The cover set number 0 related to the vertex a is:
14 {('a', 'd'), ('a', 'c'), ('a', 'b')}
15
16 To find the currently famous point: Counter({'b': 2,
      'c': 2, 'd': 2})
17 The famous point number 1 is: b
18 Currently base set after collapsing to b is: [
      frozenset({'d', 'c'})]
19 The cover set number 1 related to the vertex b is:{('
      b', 'c'), ('d', 'b')}

```

```

20
21 To find the currently famous point: Counter({'c': 1,
      'd': 1})
22 The famous point number 2 is: c
23 Currently base set after collapsing to c is: []
24 The cover set number 2 related to the vertex c is: {('d', 'c')}
25
26 .* So the cover contains of 3 sets and the upper
      bound of the category "gscat" = 2 "

```

Listing 3.6: Example 1. Partition of matroid base.

Example 3.3.5

```

1 "The following matroid represent Example 3.2.2}"
2
3 M5 = BasisMatroid(groundset='ab1234', bases=['a14', 'a43', 'a32', 'a12', 'b14', 'b43', 'b32', 'b12'])
4 cover(M5)
5 "RESULT:"
6
7 True matroid
8
9 Matroid bases:
10 [frozenset({'a', '2', '1'}), frozenset({'b', '2', '1'}),
11  frozenset({'a', '2', '3'}), frozenset({'b', '2', '3'}),
12  frozenset({'a', '1', '4'}), frozenset({'b', '1', '4'}),
13  frozenset({'a', '3', '4'}), frozenset({'b', '3', '4'})]
14
15 To find the currently famous point: Counter({'1': 4,
      '2': 4, '3': 4, '4': 4, 'a': 4, 'b': 4})
16 The famous point number 0 is: 1
17 Currently base set after collapsing to 1 is:
18 [frozenset({'a', '2', '3'}), frozenset({'b', '2', '3'}),
      frozenset({'a', '3', '4'}), frozenset({'b', '3', '4'})]

```

```
19
20 The cover set number 0 related to the vertex 1 is:
21 {'b', '2', '1'}, ('b', '1', '4'), ('a', '2', '1'),
22 ('a', '1', '4')}
23
24 To find the currently famous point:
25 Counter({'3': 4, '2': 2, '4': 2, 'a': 2, 'b': 2})
26 The famous point number 1 is: 3
27 Currently base set after collapsing to 3 is: []
28 The cover set number 1 related to the vertex 3 is:
29 {'b', '2', '3'}, ('a', '2', '3'), ('a', '3', '4'),
30 ('b', '3', '4')}
31
32 .* So the cover contains of 2 sets and the upper
   bound of the category "gscat" = 1
```

Listing 3.7: Example 2. Partition of matroid base

Chapter 4

Preorder and P-dominated point

Topological space can be associated to a preorders relation. If the topological space X satisfies the T_0 separation axiom, it can be viewed as partially order set (poset). We can use a space with its preorder to construct a simplicial complex called the order complex. Also given a simplicial complex we can define an associated space with a preorder.

Stong [44] is the first who introduces the concept of *cores* in T_0 finite space which generate by removing special points called *beat points* and keeping the homotopy type. Then May [30] generalizes Stong concept into infinite spaces. Kukiela [28] characterize pairs of spaces X, Y such that the compact-open topology on $C(X, Y)$ is Alexandroff, give a homotopy type classification of a class of infinite Alexandroff spaces and prove some results concerning cores of locally finite spaces. Barmak [6] associates A T_0 finite topological space with its poset to a finite simplicial complex, and he studied the relations between the beat points in the topological space and the dominated vertices in the simplicial complex.

In this part we want to extend their result to more general cases, as follows:

- We aim to generalize previous results over infinite preorders instead of finite posets.
- First we will extend the definition of beat point in a topological space to a new definition called *p-dominated*.

Instead of removing one beat point in each step point, the new con-

cept allows us to remove a set of points (maybe infinite). We call both operations B-collapse and P-collapse respectively.

- We show that removing this set of point which called a contraction set keeps the homotopy type of the space.
- In section 4.3, we gives some conditions where P-collapse agrees with B-collapse. And also we gives examples show spaces which is P-collapse but not B-collapse.
- In Section 4.4, we defined *P-core space* and state Theorem 4.4.10. which generalizes some previous result

So we will re-discuss the previous work on the view of the new general definition of a removable point in a space, and during our work we will try to extend the condition over the space as we can.

4.1. Alexandroff space and preorder preliminaries

In this section, we will introduce some concepts of preorder and Alexandroff topological space, for more details reader can follow Chen [15], Kukiela [28] and Timothy [43].

Definition 4.1.1 (Preorder concept). *Suppose we have $P \subseteq X \times X$ be a binary relation over a set X . For any $x, y \in X$, the notation $x \leq y$ means that $(x, y) \in P$. We denoted $P = (X, \leq)$, then:*

- P is reflexive, if $\Delta_X \subseteq P$ where $\Delta_X := \{x \leq x : x \in X\}$.
- P is transitive, if for all $x, y, z \in X$ such that $x \leq y$ and $y \leq z$, then we have $x \leq z$.
- P is antisymmetric, if $x \leq y$ and $y \leq x$ implies $x = y$.

A preorder P is a reflexive and transitive relation. And a preorder is a partial order set (poset) if it is antisymmetric. We will say that $x, y \in P$ are comparable if $x \leq y$ or $y \leq x$, denote as $x \sim y$. In other case we will say x and y

are incomparable, denote as $x \approx y$.

We say P is totally preorder, if $x \sim y$ for all x, y . A chain is a totally ordered subset of P . An antichain is a set of pairwise incomparable elements.

An element x in P is said to be maximal, if $x \leq y$ implies $y = x$. A preorder has a maximum if and only if there is a unique maximal element. The notions of minimal and minimum point are dually defined.

Define the neighborhood of a point x by $N[x] = \{y : x \sim y\}$, and $N(x) = N[x] \setminus \{x\}$.

Topological spaces are closed for arbitrary union of open sets, but they are only closed for finite intersections of open sets. In 1937, Pavel Alexandrov [5] introduce a new kind of topological spaces as follows:

Definition 4.1.2 (Topological concepts). *A topological space (X, τ) is called Alexandroff space if the arbitrary intersection of open sets is an open set.*

If (X, τ) a topological space, denote U_x to be the minimal open set contains $x \in X$ which is not always exist in the topological space in general.

Note that in Alexandroff topology $\bigcap_{x \in U} U = U_x$. So X is an Alexandroff space if and only if for all $x \in X$, the minimal open set contain x , U_x is always exist.

Note, Any finite space is an Alexandroff space.

Lemma 4.1.3. *If a space X is Alexandroff and $Y \subseteq X$, then the subspace Y of X is also Alexandroff space, such that for $y \in Y$ the minimal set contains y is $Y \cap U_y$, where U_y is the minimal set contain y in X .*

Also the intersection of Alexandroff spaces is an Alexandroff space.

Recall that a topology (X, τ) generated by a set of subsets β called the basis such that for a subset $O \subseteq X$, O belongs to τ if for every point $x \in O$, there exist $B \in \beta$ such that $x \in B \subseteq O$. Equivalently, a set O is in τ if and only if it is a union of sets in β .

Theorem 4.1.4. [43] *Let β be a collection of subsets of X , such that for each $x \in X$ there is a minimal set $m(x) \in \beta$ containing x , then β is a basis for a topology on X and X is an Alexandroff space with this topology. In addition, $U_x = m(x)$.*

In the other hand, we have the following result

Theorem 4.1.5. *If (X, τ) is an Alexandroff space, then the set $\{U_x : x \in X\}$ is a basis for τ . Moreover, this basis is the unique minimal basis of X .*

The proof is clear.

Definition 4.1.6. *A topological space X is a T_0 -space, if for any two points of X , there is an open set contains one but not contains the other. That is, the topology distinguishes points. We say X is a T_1 -space, if each point of X is a closed subset.*

Now we will discuss the relationship between preorder sets and Alexandroff spaces as follows:

In general, If we have a topological space we have a preorder over the open sets which is the inclusion.

If (X, τ) is an Alexandroff space we can define a relation \leq over X such that for two point $x, y \in X$,

$$x \leq y \iff x \in U_y \iff U_x \subseteq U_y$$

To show that this relation is a preorder, we have $U_x \subseteq U_x$, so $x \leq x$ and the relation is reflexive. Also for $x, y, z \in X$ such that $x \leq y$ and $y \leq z$, we have $U_x \subseteq U_y \subseteq U_z$ and hence $x \leq z$, so the relation is transitive.

this preorder called *specialization preorder* and denote by $\mathcal{P}(\mathcal{X})$.

If X is T_0 then its specialization preorder is a poset.

To show this, Let x, y belongs to X such that $x \leq y$ and $y \leq x$, assume there is an open set O_x contains x without y , so $x \in U_x \subseteq O_x$. Since $y \leq x$, then $y \in U_y \subseteq U_x \subseteq O_x$, a contradiction. Similarly there is no open set contains y only without x , so we have $x = y$ and the relation is antisymmetric.

In the other direction, for each preorder (P, \leq) , we may associate a topological space $\mathcal{X}(\mathcal{P})$ whose elements are those of P and whose open sets are precisely the sets $\{y : y \leq x\}$ for every $x \in P$ with respect to the preorder. This topology is an Alexandroff topology.

If the relation \leq is a poset, then $\mathcal{X}(\mathcal{P})$ is T_0 Alexandroff space.

Lemma 4.1.7. *A function between two Alexandroff spaces is continuous if and only if it is order-preserving between its specialization preorder (i.e increasing function).*

Proof. If f is continuous, and let $y \leq x$ in X , since $U_{f(x)}$ is open in Y , by continuity $f^{-1}(U_{f(x)})$ is open in X which contains x . but the minimal open set which contains x is U_x , so we get

$$y \leq x \in U_x \subseteq f^{-1}(U_{f(x)})$$

and so $f(y) \in U_{f(x)}$, hence $f(y) \leq f(x)$, done.

Conversely, to prove that $f : X \rightarrow Y$ is continuous, let V be an open set in Y , we need to show $f^{-1}(V)$ is open. So let $x \in f^{-1}(V)$, hence $f(x) \in V$. But V is open, by Theorem 4.1.5 $f(x) \in U_{f(x)} \subseteq V$.

Now for any $y \in U_x$, we have $y \leq x$, since f preserving the order $f(y) \leq f(x)$. By definition $f(y) \in U_{f(x)} \subseteq V$, so $y \in f^{-1}(V)$. Hence $U_x \subseteq f^{-1}(V)$, and so $f^{-1}(V)$ can be written as a union of open sets in X , So $f^{-1}(V)$ is open in X and f is continuous. \square

Example 4.1.8. *The category of all Alexandroff spaces and continuous maps, denoted by **AI**. Its subcategory of all T_0 Alexandroff spaces and continuous maps, denoted by $T_0\mathbf{AI}$.*

*The category of all preorders and order preserving maps, denoted by **Preorder**. Its subcategory of all posets and order preserving maps, denoted by **Poset**.*

Example 4.1.9. *The association \mathcal{X} from the **Preorder** category to the **AI** category and The association \mathcal{P} from the **AI** category to the **Preorder** category are functors.*

*Moreover they are mutually inverse functor. Dually the same hold if we exchange **AI** with $T_0\mathbf{AI}$ and **Preorder** with **Poset**.*

Hence the Alexandroff space topologies on X are in bijective correspondence with the preorders on X . The topology is T_0 if and only if the relation \leq is a poset. Also X is T_1 then its specialization order is an antichain. And X is T_1 but without T_0 , if and only if its specialization preorder is an equivalence relation.

So for the remainder of this paper, we will not make a difference between an Alexandroff space and its preorder and every space X is assumed to be an Alexandroff spaces.

Relationship between preorder and poset

Using T_0 spaces is more convenience than ordinary space. The notation and definitions are cleaner when we don't have to deal with points that are topologically indistinguishable. On the other hand, we don't lose very much by limiting the results to T_0 spaces. Since any topological space has the homotopy type of a T_0 space (Proposition 2.5 [29]).

Recall that if \sim is a relation on a topological space X , then the quotient topology on X/\sim is the final topology with respect to the quotient map $q : X \rightarrow X/\sim$. In other words, $U \subseteq X/\sim$ is open if and only if $q^{-1}(U)$ is open in X .

Proposition 4.1.10. [32] *There exist a correspondence that assigns to each Alexandroff space a T_0 homotopy equivalent space which is the quotient space X/\sim_{T_0} and the quotient map $q : X \rightarrow X/\sim_{T_0}$ is the homotopy equivalence map.*

Thus, we can restrict ourselves to T_0 -spaces, and the results on homotopy types of posets may be translated to preorders.

4.2. P -domination definition

In this section, we recall Stong [44] definition of *beat point* in a finite space, which generalized over infinite Alexandroff spaces by May [30]. After that we introduce our main concept the *p -dominated points* in an Alexandroff space which is a generalization of beat points. Also we will proof some interested results.

Definition 4.2.1 (May definition [30]). *Let (X, \leq) be an Alexandroff space,*

1. *A point $a \in X$ is up-beat if and only if $\exists b \not\leq a$ such that for all $c \not\leq a$ we have $c \geq b$,*
2. *A point $a \in X$ is down-beat if and only if $\exists b \not\geq a$ such that for all $c \not\geq a$ we have $c \leq b$.*

Linear/colinear point of Stong [44] are the up-beat/down- beat point, also Kukiela [28] denote this point as up-irreducible/down-irreducible point, in our work we will following the notation of May's [30]. Now we will define our new concepts, then we will analysis some results due to this new concepts in the rest of this chapter.

Definition 4.2.2. *Let (X, \leq) an Alexandroff space and $a, b \in X$ such that $a \not\leq b$*

1. *We say that a is p^+ dominated by b , if $c \geq a$ implies $c \sim b$. In this case we will denote A_{ab}^+ the set $\{s \in X : a \leq s < b\}$.*
2. *We say that b is p^- dominated by a , if $c \leq b$ implies $c \sim a$. In this case we will denote A_{ab}^- the set $\{s \in X : a < s \leq b\}$.*

A subset A of X is called a contraction set, if there exist two points $a, b \in X$ such that a is p^+ dominated by b , hence $A = A_{ab}^+$ or b is p^- dominated by a , hence $A = A_{ab}^-$.

In the previous notation we put the letter $-p-$ as a short-cut says that we are working over Preorder/ Poset relation, also to be short-cut says that we removing Point, so we can distinguish between the dominated points in a topological space and the dominated vertices in a simplicial complex in Definition

2.2.4.

Since every subset of Alexandroff space is Alexandroff, so we have that the space $X - A_{ab}^+$ is also an Alexandroff space. Now we will introduce our new concept of cover points:

Definition 4.2.3. *Let (X, \leq) be an Alexandroff space, $a, b \in X$ and $a \not\leq b$, we will say that:*

1. *The point b is an up-cover of a if $\forall c \not\geq a$, we have $c \geq b$ or $c \approx b$*
2. *The point a is down-cover of b if $\forall c \not\leq b$, we have $c \leq a$ or $c \approx a$.*

If both b, b' are two different up-covers for the same point, clearly that $b \approx b'$, dually for the down-covers.

Note that a point is up-beat if it has unique one up-cover, dually the point is down-beat if it has unique one down-cover.

By definitions the following lemma is clear.

Lemma 4.2.4. *Any up-beat point is a p^+ dominated, dually any down-beat point is a p^- dominated.*

So our definition is an extension for Stong definition of beat points. The next lemma is a way to define p-dominated point by using the characterising of neighbourhood.

Lemma 4.2.5. *Let (X, \leq) be an Alexandroff space, and let $a, b \in X$ such that $a \leq b$, a is p^+ dominated by b if and only if $N[a] \subseteq N[b]$. and b is p^- dominated by a if and only if $N[b] \subseteq N[a]$.*

Proof. Let a is p^+ dominated by b , and let $x \in N[a]$, so $x \sim a$

If $x \leq a$, by transitivity we have $x \leq b$, hence $x \in N[b]$.

If $x \geq a$, and by the definition of p^+ dominated, we have that $x \sim b$, done. \square

Without loss of generality, from now we will discuss the results over the p^+ dominated points, by dual the same is true for p^- dominated points, and the result may be proved for p^- dominated points the same way it is done for

p^+ dominated points.

If (X, \leq) be an Alexandroff space, we have the following two lemmas:

Lemma 4.2.6. *If a is p^+ dominated by b , so for all $s \in A_{ab}^+$, we have that s is p^+ dominated by b .*

Proof. For each $s \in A_{ab}$, if $c \geq s$ by transitivity $c \geq a$, since a is p^+ dominated, we have $c \sim b$, so s is p^+ dominated by b . \square

Lemma 4.2.7. *If a point a is p^+ dominated by b and b is p^+ dominated by c then a is p^+ dominated by c (transitive).*

Proof. If a is p^+ dominated by b , and b is p^+ dominated by c , so $a \leq b \leq c$, so $a \leq c$ by transitivity of \leq .

Now let $x \geq a$, since a is dominated by b , we have that $x \sim b$. If $x \leq b$, then $x \leq c$, done.

If $x \geq b$ and since b is dominated by c , we have $x \sim c$. So a is p^+ dominated by c . \square

Now we will extend over infinite Alexandroff space the Barmak [7] method of removing a beat point over T_0 finite spaces. Barmak defined *elementary B^+ -collapse/ B^- -collapse* to be the operation which removes up-beat/down-beat point from the space, respectively.

We state the general definition, which is removing $p^+ \setminus p^-$ dominated points as follows:

Definition 4.2.8. *Let (X, \leq) be an Alexandroff space, and let $a, b \in X$ such that $a \not\leq b$*

a. If a is p^+ dominated by b , The retraction define by $r : X \longrightarrow X - A_{ab}^+$

$$r(x) = \begin{cases} x & x \notin A_{ab}^+ \\ b & x \in A_{ab}^+ \end{cases}$$

is called an elementary P^+ -collapse from X to $X - A_{ab}^+$ if we have the retraction

- b. Similarly we have elementary P^- -collapse when we retract the contraction set A_{ab}^- to the point a .
- c. There is a P-collapse from X to a subspace Y (or a P-expansion from Y to X) if there exists a sequence of elementary P-collapses starting in X and finishing in Y . We denote this operation by $X \searrow_p Y$ or $Y \nearrow_p X$.
 - Since every up\down-beat point is a $p^+ \setminus p^-$ dominated point respectively, we define Barmak concepts (Elementary B^+ -collapse, Elementary B^- -collapse, B -collapse and B -expansion) as the same way.

Note that due to Barmak, If a point is an up-beat, then the elementary B^+ -collapse will remove only one point for each step. But in our definition, P-collapse will remove in one step a set of points (the contraction set A_{ab}) which maybe contain infinite number of points.

In the next theorem, we will show that the retract generated from an elementary P-collapse is a strong deformation retract.

Theorem 4.2.9. *Let (X, \leq) be an Alexandroff topological space, and suppose that a is p^+ dominated by b , with a contraction set A_{ab}^+ , then $X - A_{ab}^+$ is a strong deformation retract of X .*

Similarly, the retract generated from removing p^- dominated point and the retract generate from elementary P-expansion, both are strong deformation retracts also.

Proof. First we want to prove that $r : X \rightarrow X - A_{ab}^+$ is continuous, or by Lemma 4.1.7, r preserve the order.

Let $v, w \in X$ such that $w \leq v$, we have the following four cases showing that $r(w) \leq r(v)$.

- if $w \in A_{ab}^+, v \in A_{ab}^+$ then $r(w) = b = r(v)$.
- If $w \notin A_{ab}^+, v \notin A_{ab}^+$ then $r(w) = w \leq v = r(v)$.
- If $w \notin A_{ab}^+, v \in A_{ab}^+$ then $r(w) = w \leq v < b = r(v)$.

- If $w \in A_{ab}^+, v \notin A_{ab}^+$ then $r(w) = b$ and $r(v) = v$, since $a \leq w \leq v$ and a is p^+ dominated by b so $v \sim b$. If $v \leq b$ we have $a \leq v \leq b$, hence $v \in A_{ab}^+$, a contradiction. So we only have that $v \geq b$, hence $r(w) = b \leq v = r(v)$, so r is continuous.

Secondly, let $F : X \times [0, 1] \rightarrow X$ such that:

$$F(x, t) = \begin{cases} id_X(x) & t \neq 1 \\ r(x) & t = 1 \end{cases} = \begin{cases} x & t \neq 1 \\ x & t = 1, x \notin A_{ab}^+ \\ b & t = 1, x \in A_{ab}^+ \end{cases}$$

If F is continuous, then r is homotopic to the identity by a homotopy fixing $X - A_{ab}^+$, with $F(x, 0) = id_X(x)$ and $F(x, 1) = r(x)$ and this ends the proof.

Claim: F is continuous.

As we shown in Theorem 4.1.4 the topology over X has as base the set $\beta = \{U_x : x \in X\}$, so to show that F is continuous it sufficient to show that $F^{-1}(U_x)$ is an open set in $X \times [0, 1]$ for all $x \in X$. Now choose $z \in X$ we have one of the following cases depending on the relation between a and z :

- If $a \leq z \leq b$ which mean $z \in A_{ab}^+$. Note $U_z \cap A_{ab}^+ \neq \emptyset$ and $F(X \times \{1\}) = X - A_{ab}^+$. So we have

$$\begin{aligned} F^{-1}(U_z) &= U_z \times [0, 1] \cup (U_z \cap (X - A_{ab}^+)) \times \{1\} \\ &= U_z \times [0, 1] \cup (U_z - A_{ab}^+) \times \{1\} \\ &= U_z \times [0, 1] \cup (U_z - A_{ab}^+) \times [0, 1] \end{aligned}$$

For every $z \in A_{ab}^+$ the set $U_z - A_{ab}^+$ is open in X , to show this let $x \in U_z - A_{ab}^+$, so $x \leq z$ and $x \notin A_{ab}^+$, also $x \in U_x$, it is clear that $U_x \subseteq U_z$.

Now suppose to contrary $\exists y \in U_x$ and $y \in A_{ab}^+$, so we have $a \leq y \leq x \leq z \leq b$ so $x \in A_{ab}^+$, a contradiction. Hence U_x subset of the complement of A_{ab}^+ .

So we have $x \in U_x \subseteq U_z - A_{ab}^+$, so $U_z - A_{ab}^+$ is open in X . And $F^{-1}(U_z)$ is open set in $X \times [0, 1]$.

- If $z \geq b$, so $F^{-1}(U_z) = U_z \times [0, 1] \cup (U_z \cup A_{ab}^+ \cup \{b\}) \times \{1\}$. But for all $y \in A_{ab}^+$, $y \leq b \leq z$, and $y \in U_z$, so $A_{ab}^+ \subseteq U_z$ also $b \in U_z$. So

$F^{-1}(U_z) = U_z \times [0, 1) \cup U_z \times \{1\} = U_z \times [0, 1]$ Which is open set in $X \times [0, 1]$.

- If $z \not\leq a$, so $U_z \cap A_{ab}^+ = \emptyset$, and $F^{-1}(U_z) = U_z \times [0, 1]$ is an open set in $X \times [0, 1]$.
- Finally, if $z \approx a$, so $F^{-1}(U_z) = U_z \times [0, 1]$ is an open set in $X \times [0, 1]$.

□

We can prove the second part in the proof (showing that r and id_X are homotopic) by using the following result from [28], since $r \leq id_X$ and they are equal over A_{ab}^+ .

But we keep our proof because we think our proof is direct, shorter and interest by itself.

Recall $C(X, Y)$ denotes the space of all continuous maps $X \rightarrow Y$ in the compact-open topology.

Theorem 4.2.10. [28] *Let X, Y be Alexandroff spaces. If $f, g \in C(X, Y)$ are such that $f(x) \sim g(x)$ for all x , then f is homotopic to g by a homotopy that is constant on the set $\{x \in X : f(x) = g(x)\}$.*

In the next section we will show that, in T_0 finite spaces, both B-collapse and P-collapse are closely related (both can yield to the same subspace A after both ways of collapsing), so if we assume that X is T_0 finite we can proof Theorem 4.2.9 using a result in Barmak [6] which states: A finite space X is B-collapses to $A \subseteq X$ if and only if A is a strong deformation retract of X .

Now we will state the following corollary following Theorem 4.2.9.

Corollary 4.2.11. *If a space X contains a distinguished point p such that p is a maximum point or a minimum point, then X is a P-collapsible to this point, and so p is strong deformation retract of X .*

In general, If all maximal chains in X contain p as a common point, then X is contractible to p .

Proof. To proof the general case, let p be a common point between all maximal chains in X , select any point x , it will belong to some maximal chain C , so $x \sim p$.

If $x \leq p$, and for all $y \geq x$ we have that $y \sim p$, so x is p^+ -dominated with p . Similarly, if $x \geq p$, then x is p^- -dominated by p , and X is P-collapsible to p . And hence X is contractible to p . \square

Example 4.2.12. *If X is an Alexandroff space which is totally preorder, X is homotopy equivalent to a point, because every two elements are comparable.*

Future work

Barmak proof the following lemma:

Lemma 4.2.13. *A finite space X is contractible if and only if one can remove beat points from X one at a time to obtain a space consisting of only one point.*

We want to extend this result over infinite spaces using p -dominated concept as follows:

Lemma 4.2.14. *Any Alexandroff space (finite or infinite) X is contractible if and only if one can remove contraction sets one at a time to obtain a space consisting of only one point.*

We proof the second direction by Theorem 4.2.9 and we seek to proof the first direction.

4.3. Relationship between P-collapse and B-collapse

Now we will discuss relations between up-beat/down-beat points and p^+/p^- -dominated points through our main theorem 4.3.5 which shows that P-collapse and B-collapse operations are similar if the space contains only finite chains.

Hasse diagrams is a useful way to represent T_0 -spaces, that makes easy to recognize beat points and p-dominated points looking into the diagram of the space, for more details follow Barmak [6].

We can define Hasse diagram for preorder space, but to avoid the two direction edges we define Hasse diagram over poset space.

Definition 4.3.1. *The Hasse diagram of a poset X is a directed graph whose vertices are the points of X and whose directed edge are the ordered pairs (x, y) such that y is an up-cover of x . A point x is lower than y if we can move through continuous sequence of directed edges starting at x and ending at y .*

Example 4.3.2. *The following Hasse diagram, represents a space $X = \{a, b, c, d\}$ with preorder P defines as: $a \leq c$, $b \leq c$, $c \leq d$, $a \leq d$, and $b \leq d$. Also P is reflexive relation. This space have a maximum d so it is contractible.*



Figura 4.1: Hasse diagram

Definition 4.3.3. *An Alexandroff space (or subspace) is finite-chain, if and only if it contains only finite chains.*

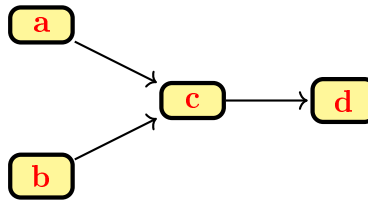

In this example we will show a not finite space which is finite-chain space.

Example 4.3.4. Let $X =: \{(n, i) \in \mathbb{N} \times \mathbb{N} : i \leq n\} \cup \{a\} \cup \{b\}$

We denote the point (n, i) by ni .

define the preorder relation by:

(1.) $ni \leq mj$ if and only if $m \leq n$ and $i \leq j$

(2.) For any point ni , $a \leq ni \leq b$.

The following is the Hasse diagram:



Figura 4.2: Infinite space which is a finite-chain space

Clearly every point ni is p^+ dominated by b . Also a is p^+ dominated by b , hence X equal to the contraction set $A_{ab}^+ \cup \{b\}$, and this contraction set is elementary P-collapsible to the maximum point b .

Following the next more general theorem we show that this infinite space X which elementary P^+ -collapsible to a point only on one operation, is also B^+ -collapsible to a point (in the sense of Barmak) but passing through infinite sequences of B^+ -collapse operations.

Theorem 4.3.5. In Alexandroff space X . If we have the contraction set A_{ab}^+ as a subspace with property that every chain in A_{ab}^+ is finite.

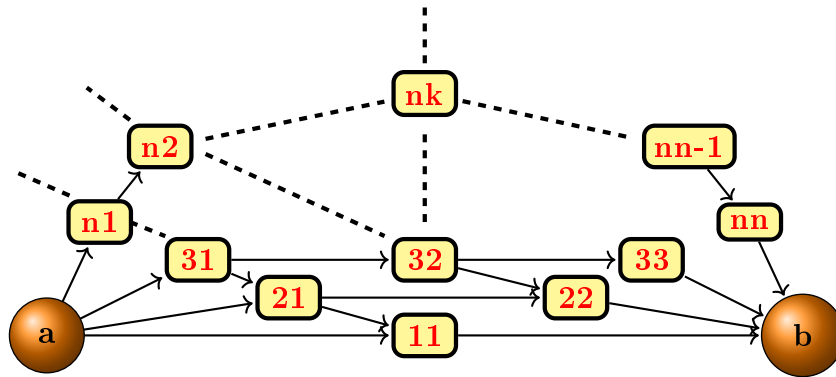
Then the operation of elementary P^+ -collapse the set A_{ab}^+ can be represented by sequences of B^+ -collapses in at most ω steps, where ω is the first ordinal.

Similarly, Elementary P^- -collapse a contraction set A^- can be represented by sequences of B^- -collapses removing down-beat points.

Proof. Assume that a is p^+ dominated by b with a contraction set A_{ab}^+ .

If $A_{ab}^+ = \{a\}$, then it is easy to show a is a up-beat point under b .

If $\{a\} \subsetneq A_{ab}^+$, we can construct a decreasing sequence of sets $\{Y_i : Y_i \subseteq A_{ab}^+ \cup \{b\}\}$, which decreasing by inclusion $Y_0 \subseteq Y_1 \subseteq \dots$ such that:

1. $Y_0 = A_{ab}^+ \cup \{b\}$,
2. Assume we have Y_i defined for every $i < n + 1$, and we will define $Y_{n+1} = Y_n - D_n$ where $D_n = \{x \in Y_n : x \neq a, \nexists y \in Y_n - \{b\} \text{ such that } x \preceq y \preceq b\}$ (in other words, D_n contains all the down-cover points of b in the currently set Y_n).

For each step i , we define a retract, the map $r_i : Y_i \rightarrow Y_{i+1}$ to collapse the set D_i to the point b , in the following way:

$$r_i(x) = \begin{cases} b & x \in D_i \\ x & \text{elsewhere} \end{cases}$$

3. Since for every finite step $i, Y_{i+1} \subseteq Y_i$, we can defined the first infinite step ω as $Y_\omega = \bigcap_i Y_i$. Note for all $i, \{a, b\} \in Y_i$ so $\{a, b\} \in Y_\omega$.

By Lemma 4.1.3, we have for all i, Y_i and Y_ω are also Alexandroff spaces.

Firstly, we need to show whenever $Y_i - \{a, b\} \neq \emptyset$ for a fixed i , then $D_i \neq \emptyset$. Assume to contrary that $D_i = \emptyset$, we can construct an infinite strictly increasing sequence (chain) (a_j) , in the following way:

we start with $a_0 = a$, let $a_1 \in Y_i - \{a, b\}$, so $a_0 \preceq a_1 \preceq b$. Since $a_1 \notin D_i$ so there exist $a_2 \in Y_i$ such that $a_1 \preceq a_2 \preceq b$ and $a_2 \notin D_i$. Continue to construct (a_j) such that for every a_j we can find $a_{j+1} \in Y_i$ such that $a_j \preceq a_{j+1} \preceq b$, this sequence infinite, contradict that X is finite chain space.

Secondly, we want to show that for every $x \in A_{ab}^+ - \{a\}$, there exist some step i , such that $x \in Y_i, x \notin Y_{i+1}$ and x is a up-beat under b in Y_i hence x collapsed by r_i , that is equivalent to prove $A_{ab}^+ - \{a\} = \bigcup_i D_i$.

So suppose to contrary we have a point $c \in A_{ab}^+ - \{a\} - \bigcup_i D_i$, so for all $i, c \notin D_i$, so there exist $c_i \in A_{ab}$ such that $a \preceq c \preceq c_i \preceq b$. And we have the following:

1. For a fixed step i and $d \in D_i$, by definition of D_i we have no point greater than d in $Y_i - \{b\}$, since all points $x \in A_{ab}, d \not\leq x \not\leq b$ is already collapsed with some map r_j , where $j < i$. So c is not greater than d for any $d \in \bigcup D_i$.

2. Also, c is not smaller than d for all $d \in \bigcup D_i$.

Hint: If there exist $d \in D_j$ for some step j such that $c \leq d$, we will show the contradiction by constructing a chain start with d and end with c , this chain will be finite and each point will be down-cover for the previous point, so c will belongs to some D_i which is a contradiction.

Now starting with the chain $C_0 = \{c, d\}$ in Y_j , let $c_0 = d$.

If c is down-cover of d done.

if not, this mean $\exists x \in Y_j$ such that $c \not\leq x \not\leq d$, we add x to C_0 . We continue add elements to the chain C_0 as follows:

for any two consequent points in C_0 , say x, y ,

If x is down-cover of y , done.

If not, then $\exists y \in Y_j$ such that $x \not\leq z \not\leq y$ and add z to C_0 , we repeat this process until we get a point y' which is a down-cover of y and we rename $y = c_m, y' = c_{m+1}$ for some m .

Continue adding points to C_0 until we construct a chain $C' \subseteq X_j$ such that every point is a down-cover to the next point. Because X is finite-chain, every chain is finite, so there is a moment that we cannot add more points to this chain. So we can write the finite chain C as $C = \{c_r : c_{r+1} \leq c_r, r \leq n \text{ for some } n\}$. Now every point in C will belongs to some D_i where $j \leq i \leq n + j$, so $c = c_n \in D_{j+n}$. A contradiction since $c \notin \bigcup_i D_i$.

3. Step 1. and Step 2. show that $c \approx d$, for all $d \in D_i$. But there exist $c_1 \in A_{ab}, c \not\leq c_1 \not\leq b$. Since $c \sim c_1$, then c_1 also not belong to $\bigcup D_i$ [If c_1 belongs to some D_i , so $c_1 = d \in D_i$, then $c \leq c_1 = d$ a contradiction as we show in Step 2], so also $c_1 \approx d, \forall d$. Now we can repeat this step infinity many time to construct an infinity strictly increasing sequence (c_j) , A contradiction because X finite-chain space.

So c have to belong to $\bigcup_i D_i$. Since $A_{ab} - \{a\} = \bigcup_i D_i$, we have that $Y_\omega = \bigcap Y_i = A_{ab} - \bigcup_i D_i + \{b\} = \{a, b\}$ and at the step ω the point a is up-beat

point under b .

Finally, for all $d \in D_i$, d is up-beat point under b over Y_i , we want to show that d also is up-beat point under b over the currently space $X \cap Y_i$ after i steps of collapses. Suppose to contrary the converse, for some i , let D_i contains a non up-beat point s , so s have at least two up-cover, the point b is one of these covers, let b' be another up-beat of s that means $b \approx b'$, but $a \leq s \leq b'$ so by domination of a by b , we have $b \sim b'$. So $\forall i$, and $\forall x \in D_i$, x is up-beat point in the currently space $X \cap Y_i$ (note that this space is also Alexandroff space).

For the contraction set A_{ab} , the number of up-beat points in $A_{ab} = |A_{ab}|$. □

So in a finite-chain space X both operation P-collapse and B-collapse can reduce the space to homotopy equivalent subspaces X_P and X_B respectively, where both are strong deformation retract of X , But applying the P -collapse over X , we reach X_P more faster.

Now we will present several examples to clarify the difference between P-collapse and B-collapse.

Our first example shows a P-collapsible contraction set A_{ab}^+ contains an infinite chain. For this space we start B-collapse the space with the points which is the down-cover of b as a beat points. But there is some points can not B-collapse in any step. So A_{ab}^+ is P-collapsible but not B-collapse. We conclude that P-collapse differs from B-collapse.

Next we show that in some cases the set A_{ab}^+ have infinite chain but we can B-collapse all the set (starting B-collapse the points which is currently a down-cover of b until we reach a). So this space is B-collapsible also.

Finally we show example that we never have any beat points to start the B-collapse operation over A_{ab}^+ , so this space can collapsed only in our sense and we can not operate any elementary B-collapse.

Example 4.3.6. *This counter example shows a space -with infinite chains- which is not B^+ -collapsible but it is a P -collapsible to a point. The following is the Hasse diagram:*



Figura 4.3: P -collapsible, but not B^+ -collapsible space.

Let

$$X = \{(1, 1), (a, 0), (b, 0), (0, 0)\} \cup \{(a, 1/n), (b, 1/n) : n \in \mathbf{N}\}.$$

With the preorder spanned as: $(0, 0)$ a minimum, and $(1, 1)$ a maximum point

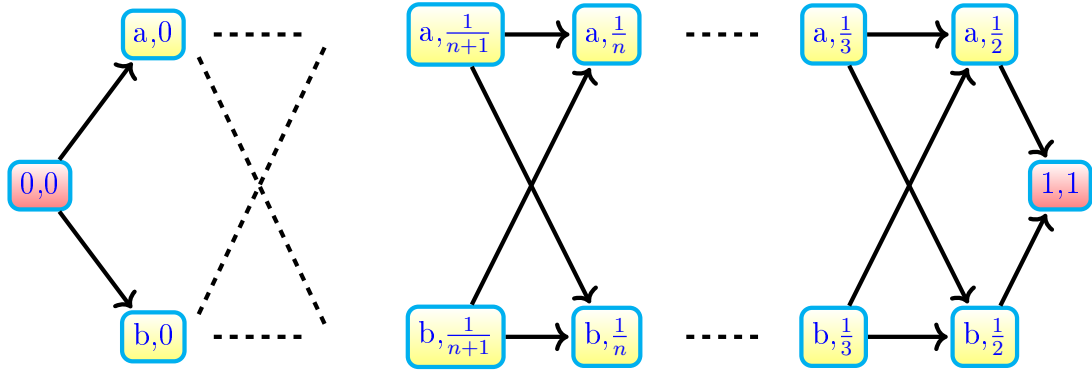
$$\forall n, (a, 1/(n+1)) \leq (a, 1/n), (a, 1/(n+1)) \leq (b, 1/n)$$

$$\forall n, (b, 1/(n+1)) \leq (a, 1/n), (b, 1/(n+1)) \leq (b, 1/n)$$

$$\forall n, (a, 0) \leq (a, 1/n), (a, 0) \leq (b, 1/n)$$

$$\forall n, (b, 0) \leq (a, 1/n), (b, 0) \leq (b, 1/n)$$

The point $(0, 0)$ is p^+ dominated by $(1, 1)$ with contraction set $A_{(0,0)(1,1)}^+$. So the space $X = A_{(0,0)(1,1)}^+ \cup \{(1, 1)\}$, such that $X \searrow^p \{(1, 1)\}$.

As the previous theorem, $Y_0 = A_{(0,0)(1,1)} \cup \{(1, 1)\}$ has only two up-beat points, where we can start the sequence of B^+ -collapse under $(1, 1)$ as follows:

$(a, 1/2)$ is up-beat point, so we can elementary B^+ -collapse it to the point $(1, 1)$, then repeat the same for the point $(b, 1/2)$, and we have the subspace Y_1 .

In second step, the point $(a, 1/3)$ and $(b, 1/3)$ become a new up-beat points in Y_1 , so we can B^+ -collapse them in two different steps and replace them by $(1, 1)$, and so on \dots .

But the point $(a, 0)$ will never be an up-beat point under any point x in any step n , to show this, fixed any subspace Y_i , pick any point $x = (a, 1/n) \not\geq (a, 0)$ we have $(a, 1/n) \geq (a, 1/\{1+n\}) \geq (a, 0)$.

And if $x = (b, 1/n) \not\geq (a, 0)$, we have $(b, 1/n) \geq (b, 1/\{1+n\}) \geq (a, 0)$.

So in this example, we show that X is P -collapsible to a point in one step only. But in the sense of removing up-beat points, we have infinitely steps of elementary B^+ -collapses. Moreover, there exist two points $(a, 0), (b, 0)$ in $A^+_{(0,0)(1,1)}$ which never be an up-beat point.

Example 4.3.7. We show a contraction set with infinite-chains, this P^+ -collapsible set can represented by sequences of B^+ -collapse, we can start the B^+ -collapse steps with the up-beat points which is the down-cover of b , until we B^+ -collapse every point in X . The following is the Hasse diagram:



Figura 4.4: P -collapsible and B^+ -collapsible space.

$$X = \{0, 1\} \cup \{\pm 1/n : n \in \mathbf{N}, n \neq 1\},$$

The preorder spanned as: $\pm 1/n \leq \pm 1/m$ iff $n \geq m$,

$a = 0$ as a minimum point, $b = 1$ as a maximum point.

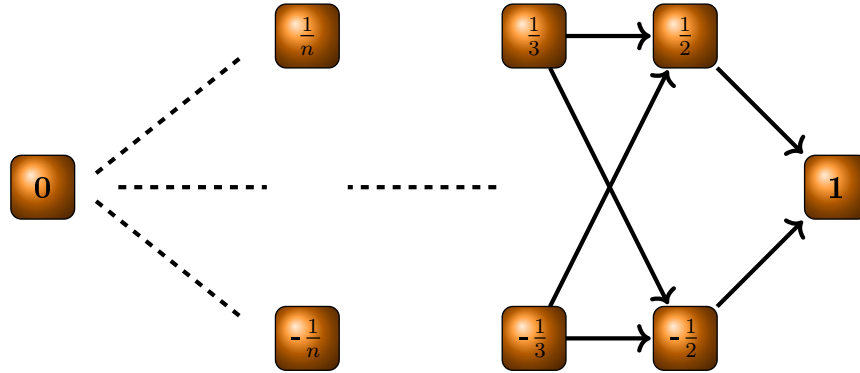
Note $X = A_{01} \cup \{1\}$ which have infinite chain $\{1/n : n \in \mathbf{N}\}$. Following the notation of proof Theorem 4.3.5, $D_n = \{x \in Y_n : a \neq x = \pm 1/n\}$, (i.e. the only

up-beat points in step n are the two point located as a down-cover of the point 1), and $A_{01} - \{0\} = \bigcup_n D_n$. The last B^+ -collapse step is $Y_\omega = \bigcap_n Y_n = \{0, 1\}$ and now 0 is up-beat of 1 and we elementary B -collapse 0.

Example 4.3.8. We show a contraction set A_{ab} contains infinite chains and no point is up-beat or down-beat, so we can not start B -collapsing points under b . But the space is P -collapsible to a point. The following is the Hasse diagram:



Figura 4.5: P -collapsible space with no elementary B^+ -collapse

$$A_{ab} = \{0, 1\} \cup \{(x, \pm \frac{1}{n}) : x \in \{a, b\}, n \in \mathbf{N} - \{1\}\},$$

Let $m \leq n$ and $x, x' \in \{a, b\}$, the preorder spanned as:

$$(x, \frac{1}{m}) \leq (x', \frac{1}{n}) \text{ and } (x, -\frac{1}{m}) \leq (x', -\frac{1}{n}).$$

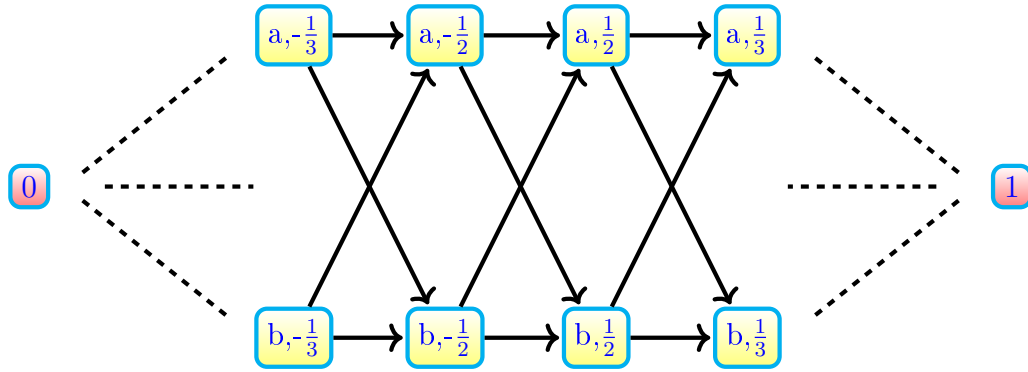
$a = 0$ as a minimum point, and $b = 1$ as a maximum point.

Stong [44] states many results of beat points and B -collapse over finite spaces, Kukiela [28] generalize this result to infinite X with some finiteness conditions.

We can apply results from Stong, May, Kukiela and Barmak to our definition (p -dominated points and P -collapse), if the space is chain-finite, using Theorem 4.3.5.

4.4. Homotopic spaces and their core

Kukiela [28] stated some finiteness condition over the space that will allowed to construct a special subset of X calling (*Core*) and studied the relations between the cores of two homotopic spaces, In this section we state his definitions and merge the idea of P-domination, then we will extend his main theorems using the P-domination concepts. Our main Result is Theorem 4.4.10, now we start by recall several concepts

Definition 4.4.1. *Let X be an Alexandroff space. A retraction $r : X \rightarrow A \subseteq X$ is called:*

1. a comparative retraction, if $r(x) \sim x$ for every $x \in X$,
2. an up-retraction, if $r(x) \geq x$ for every $x \in X$,
3. a down-retraction, if $r(x) \leq x$ for every $x \in X$,
4. a retraction removing a contraction set, if exists a point $a \in X$ such that a is p^+ dominated point under some u_a , or a is p^- dominated point over some d_a and such that

$$u(x) = \begin{cases} u_a & x \in A_{au_a}^+ \\ x & x \notin A_{au_a}^+ \end{cases} \quad d(x) = \begin{cases} d_a & x \in A_{ada}^- \\ x & x \notin A_{ada}^- \end{cases}$$

5. a retraction removing a beat point, if exists a point $a \in X$ being an up-beat point under some u_a , or a down-beat point over some d_a and such that

$$u(x) = \begin{cases} u_a & x = a \\ x & x \neq a \end{cases} \quad d(x) = \begin{cases} d_a & x = a \\ x & x \neq a \end{cases}$$

Follows from Lemma 4.2.4 that retractions removing a beat point is a special case of retraction removing a contraction set which is an up- or down-retractions. All of them are comparative retraction. Moreover, every comparative retraction may be written as a composition of an up-retraction and a down-retraction

Definition 4.4.2. [28] In the category of Alexandroff spaces, let \mathcal{C} denote the class of all comparative retractions, \mathcal{U} and \mathcal{D} classes of, respectively, up- and down-retractions, \mathcal{P} the class of retractions removing contraction set of a p -dominated point. and \mathcal{B} the class of retractions removing a beat point.

Definition 4.4.3. A non empty Alexandroff space X is said to be a \mathcal{C} -core if there is no retraction $r : X \rightarrow r(X)$ in \mathcal{C} other than identity id_X . Also, we defined \mathcal{P} -core if there is no p^+/p^- -dominated point, and \mathcal{B} -core if there is no up-beat/down-beat point.

From the definitions, every \mathcal{C} -core is a \mathcal{P} -core. and every \mathcal{P} -core is a \mathcal{B} -core since every up/down beat point is a p^+/p^- dominated point. Kukiela proof that every finite-chain \mathcal{B} -core is a \mathcal{C} -core. We will proof later in Corollary 4.4.9 that a \mathcal{P} -core is a \mathcal{C} -core, if the space satisfies a condition called *bounded space*.

Stong [44] state cores are required to be strong deformation retracts of the finite space they are contained in.

We call the following definition and theorem from Kukiela

Definition 4.4.4. [28] In an Alexandroff space X , we say:

- A sequence $\{x_n : n \in A \subseteq X\}$ of elements of X is s -path, if $x_i \neq x_j$ for $i \neq j$ and $x_{i-1} \sim x_i$ for all $i > 0$.
- X is a finite-paths space (fp-space), if every s -path of elements of X is finite,
- X is chain-complete, if every chain has both a supremum and an infimum.

We recall the following main theorem from Kukiela which is a generalization of Stong result over a finite space.

Theorem 4.4.5. [28] If X is a \mathcal{C} -core fp-space, then there is no map in $\mathcal{C}(X, X)$ homotopic to id_X other than id_X .

Since every fp-space satisfies the chain-finite property, and not every \mathcal{P} -core is a \mathcal{C} -core. So using Theorem 4.3.5 we can generalize this theorem for \mathcal{P} -core fp-space.

Through Kukiela proof he use the idea of absence the beat points to proof the result on a finite-paths (fp-space). We will defined *the bounded space* then we will improve Theorem 4.4.5 which is over fp-space to generalize it over *bounded space* using the idea of absence the P-dominated points to state more simply and extending proof.

First we introduce the definition of bounded spaces.

Definition 4.4.6. *Let X an Alexandroff space, denote $\max(X)$ the set of all maximal point in X and the set $\min(X)$ to be the set of al minimal point in X , then X is called:*

- Up-bounded space, *if for every $x \in X$, there exist $m \in \max(X)$ such that $m \geq x$.*
- Down-bounded space, *if for every $x \in X$, there exists $n \in \min(X)$ such that $n \leq x$.*
- Bounded space, *if X both up-bounded space and down-bounded space.*
- Finite-bounded space, *if X is bounded space and both sets $\max(X)$ and $\min(X)$ are finite.*

This example shows the differ between finite-bounded space and fp-space

Example 4.4.7. *In Example 4.3.6, The space $X = \{(1, 1), (0, 0)\}$ have the following Hasse representation.*

Where the set $\max(X) = \{(a, 1/2), (b, 1/2)\}$ and $\min(X) = \{(a, 0), (b, 0)\}$.

We can find an infinite s-path. So X is an infinite \mathcal{P} -core which is finite-bounded space, but not a fp-space.



Figura 4.6: Finite bounded but not fp-space.

Now we state and prove the following three results:

Theorem 4.4.8. *Let X is a \mathcal{P} -core, and let $f : X \rightarrow X$ a continuous map.*

- *If X up-bounded space and $f \geq id_X$, then $f = id_X$.*
- *If X down-bounded space and $f \leq id_X$, then $f = id_X$.*
- *That is if X bounded and $f \sim id_X$, then $f = id_X$.*

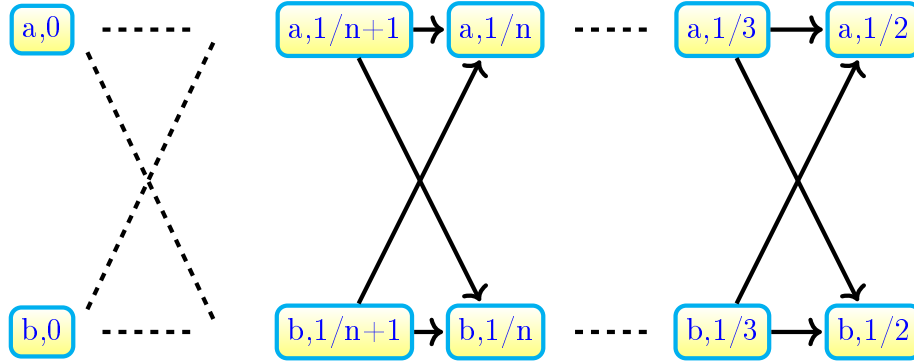
Proof. If $f \geq id_X$, for every $m \in \max(X)$ we have $f(m) \geq id_X(m) = m$, So $f(m) = m$. Now let $y \in X$ such that for all $x \geq y$, $f(x) = x$ and $f(y) \not\geq y$. Since y is not maximal and X is a \mathcal{P} -core then y is not a p^+ -dominated point and so there exist another up-cover point of y differ than $f(y)$, say $z \in X$, $f(y) \approx z \not\geq y$, Since f is continuous and hence preserving order, so we have $z = f(z) \geq f(y)$ and $f(y) \sim z$. A contradiction.

Similarly, if $f \leq id_X$ then $f = id_X$. □

Corollary 4.4.9. *Every bounded \mathcal{P} -core is a \mathcal{C} -core.*

Proof. If X is bounded \mathcal{P} -core, so every comparative retraction $r(x) \sim x$ for every $x \in X$ equal to the identity id_X . Hence X is \mathcal{C} -core □

Now we state an improvement of Theorem 4.4.5 also we state more simply and extending proof:

Theorem 4.4.10. *Let X be a \mathcal{C} -core bounded space, If one of the following satisfies*

- X is finite bounded.
- $C(X, X)$ is Alexandroff.

There is no map in $C(X, X)$ homotopic to id_X other than id_X .

To proof Theorem 4.4.10, we state this following concepts to simplify the idea of the proof.

Proposition 4.4.11. *[28] Let X, Y be Alexandroff spaces. The family $\{[x, U_y] : x \in X, y \in Y\}$ where $[x, U_y] = \{f : X \rightarrow Y \mid f(x) \leq y\}$ is a subbasis for the compact-open topology on $C(X, Y)$.*

Lemma 4.4.12. *[28] Let X be an Alexandroff space, Y an arbitrary topological space. Maps $f, g : X \rightarrow Y$ are homotopic if and only if they belong to the same path component of $C(X, Y)$.*

Lemma 4.4.13. *Let X be \mathcal{C} -core bounded space, if x is not maximal point, then at least two different maximal points m, \bar{m} are greater than x . Similarly, if x not minimal, then $\exists n, \bar{n} \in \min(X), n \leq x, \bar{n} \leq x$, and $n \approx \bar{n}$*

Proof. Suppose to contrary that there exist one maximal say $m_x \geq x$. For any $y \geq x$, if m_y is any maximal greater than y , then it is also a maximal of x , so $m_y = m_x$, hence $y \leq m_x$ and so x is p^+ dominated by m_x . But X is a \mathcal{C} -core, which is a \mathcal{P} -core with no p -dominated points, a contradiction. \square

This example to clarify the previous lemma

Example 4.4.14. *The following sketch represent a preorder set, where every maximum point (the m 's point) have two down-cover point and every minimal (the n 's point) have two up-cover point, so there is no p -dominated points and the space is a \mathcal{P} -core. Moreover the space have no up-beat or down beat points, which is \mathcal{B} -core.*

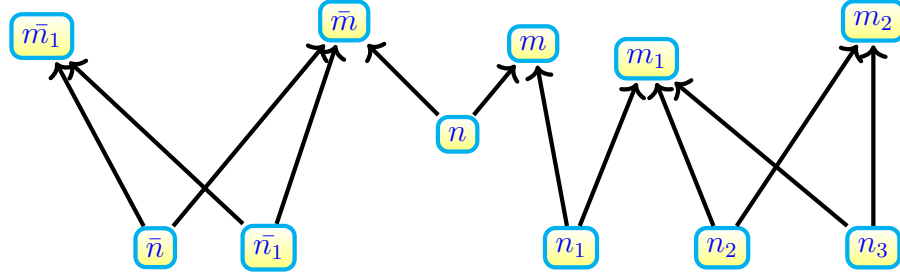
Figura 4.7: \mathcal{B} -core and \mathcal{P} -core space

Construction If X is a \mathcal{C} -core bounded space, then for every $x \in X$ we can construct a \mathcal{B} -core subspace A_x where $x \in A_x \subseteq X$, as follows:

Let $x \in X$ and fix it,

- If x is not a maximal, so by previous lemma $\exists m_x, \bar{m}_x \in \max(X)$, and if x is not a minimal, so $\exists n_x, \bar{n}_x \in \min(X)$, Add $x, m_x, \bar{m}_x, n_x, \bar{n}_x$ to A_x . Now for the currently A_x , we will add the following points together with the following relations.
 - If the point is a maximal point in A_x , say m , so there exist $a \in A_x$ such that $a \leq m$. Also m is not p^- -dominated in by a X , so $\exists \bar{a} \in X, \bar{a} \approx a, \bar{a} \leq m$, add \bar{a} to A_x .
 - If the point is a minimal in A_x , say n , there exist $a \in A_x$ such that $a \leq n$. Also n is not p^+ -dominated by a so $\exists \bar{a} \in X, \bar{a} \approx a, n \leq \bar{a}$, add \bar{a} to A_x .
 - If $a \in A_x$, not a maximal and not a minimal in A_x , so there exist a maximal point or minimal point in A_x comparable with a . From X we select maximal and minimal points and add them to A_x in order to let the point a having two maximals and two minimals in A_x . Note that the two maximal m_a, \bar{m}_a represent two up-cover of a , so a is not up-beat. Moreover, since m_a is maximal then a is not p^+ -dominated by m_a nor \bar{m}_a . And the two minimals represent two down-cover of a .

Note that the preorder in A_x describe only in the previous steps,

and we not import from X all relations between the elements, so we guarantee that A_x is a \mathcal{B} -core.

In the same way we can show that every point in A_x is not up-beat nor down-beat. We continue in the same steps to construct a sequences of points belong to A_x which is \mathcal{B} -core, since the inner points (not maximals, not minimals) are not comparable together in A_x .

- If x is a maximal point, which is not down-beat , $\exists a, \bar{a}$ down-cover of x and then we can construct $A_x = A_a \cup A_{\bar{a}}$,
- Similarly if x is a minimal point.

Whenever $\max(X)$ and $\min(X)$ are finite, we will stop adding points to A_x in the moment which we add a point $a \in A_x$ such that both maximals and both minimals of a are repeated in A_x , so A_x is finite.

Theorem 4.4.10 proof. ▪ First for every $x \in X$, we construct A_x which is \mathcal{P} -core

- If $f \in \bigcap_{y \in A_x} [y, U_y]$, then $f|_{A_x} = id_{A_x}$.
To show this, suppose the converse, that is, $\exists a \in A_x$ such that $f(a) \not\leq a$, so a is not a minimal point so there exist a minimal point $n \in A_x, n \not\leq a, f(a) \approx n$. Since $n \in A_x$ so $f(n) \leq n$, and n is minimal, so $f(n) = n$. by continuity of $f, f(n) \leq f(a)$. We have the contradiction $n = f(n) \leq f(a)$ but $f(a) \approx n$.
- For every x , the set $[x, u_x]$ is an open neighbourhood of id_X in $C(X, X)$ by Corollary 4.4.11. We have the following two cases guarantee that the set $\bigcap_{y \in A_x} [y, u_y]$ is open.
 1. If X is finite bounded spase, then A_x is finite and the set $\bigcap_{y \in A_x} [y, u_y]$ is a finite intersection of open set which is open in $C(X, X)$.
 2. If $C(X, X)$ is Alexandroff space, then any intersection of open sets is open, so $\bigcap_{y \in A_x} [y, u_y]$ is open even if A_x infinite set.

- To show $\bigcap_{y \in A_x} [y, u_y]$ is a closed set, let $g \notin \bigcap_{y \in A_x} [y, u_y]$, this mean $g \notin \{f \in C(X, X), f(y) \leq y, \forall y \in A_x\}$, so $\exists a \in A_x$ such that $g(a) \not\leq a$ or $g(a) \approx a$. We have:
 - If $g(a) \not\leq a$, so a is not a maximal so $\exists m \in \max(X), m \geq a, m \approx g(a)$. If $g(m) \leq m$, by continuity of g , we have $m \approx g(a) \leq g(m) \leq m$ a contradiction, so $g(m) \not\leq m$.
But m is a maximal then $m \not\leq g(m)$.
Hence $g(m) \approx m$. Now take O the open set $[m, U_{g(m)}]$.
 - If $g(a) \approx a$, take O the open set $[a, U_{g(a)}]$.

When $O = [m, U_{g(m)}]$, suppose to contrary that there exist

$$f \in C(X, X), f \in [m, U_{g(m)}] \bigcap \left(\bigcap_{y \in A_x} [y, U_y] \right)$$

so $f(m) \leq g(m)$. And $\forall y \in A_x, f(y) = y$ (as we proof above). But $m \in A_x$ so $f(m) = m$, we have the contradiction $m \leq g(m) \approx m$. So

$$[m, U_{g(m)}] \bigcap \left(\bigcap_{y \in A_x} [y, U_y] \right) = \phi.$$

So

$$g \in [m, U_{g(m)}] \subseteq \left(\bigcap_{y \in A_x} [y, U_y] \right)^c$$

Similarly for the case $O = [a, U_{g(a)}]$.

So $g \in O \subseteq \left(\bigcap_{y \in A_x} [y, U_y] \right)^c$. And $\bigcap_{y \in A_x} [y, U_y]$ is clopen set in X .

- The connected component of id_x is subset of the the quasi component of id_X (= the intersection of all clopen sets containing id_X). It follows that the quasi-component which is contained in $\bigcap_{x \in X} \bigcap_{y \in A_x} [y, u_y] = id_X$. by Lemma 4.4.12 there is no map in $C(X, X)$ homotopic to id_X other than id_X .

□

Theorem 4.4.15. *Suppose X and Y are Alexandroff spaces, and suppose that they both have finite bounded \mathcal{C} -cores X^C and Y^C . Then X is homotopy equivalent to Y if and only if X^C is homeomorphic to Y^C .*

Proof. Suppose that X, Y are homotopy equivalent, also from Theorem 4.2.9 X, X^C are homotopy equivalent and Y, Y^C are homotopy equivalent, so X^C, Y^C are homotopy equivalent and hence there exist two continuous function $f : X^C \rightarrow Y^C$ and $g : Y^C \rightarrow X^C$ such that $f \circ g \simeq id_{Y^C}$ and $g \circ f \simeq id_{X^C}$. Since X^C is finite bounded \mathcal{C} -core and $f \circ g : X^C \rightarrow X^C$, by Theorem 4.4.5 $f \circ g = id_{Y^C}$ and similarly $f \circ g = id_{Y^C}$, so we have the homeomorphism.

Conversely, suppose X^C and Y^C are homeomorphism, and every homeomorphism is a special case of homotopy equivalent, and every space is homotopy equivalent to it's \mathcal{P} -core, so X homotopy equivalent to Y . \square

4.5. Between topological spaces and simplicial complex

McCord [32] investigated the relationship between Alexandroff spaces and simplicial complexes, as the following.

- If we have an Alexandroff space X , the *associated simplicial complex* $\mathcal{K}(X)$ called *order complex* which it's simplices are the non-empty finite chains of X , so points of X represent vertices in the complex $\mathcal{K}(X)$.
- Conversely, If we have a simplicial complex K , we define *the associated finite space* $\mathcal{X}(K)$ as the preorder of simplices of K ordered by inclusion. Since if we have two simplices $\sigma, \tau \in K$ such that $\sigma \subseteq \tau, \tau \subseteq \sigma$ then $\sigma = \tau$, so this preorder over $\mathcal{X}(K)$ is a poset.

Example 4.5.1. *Let the following Hasse diagram represent a finite space.*



Figura 4.8: Finite Alexandroff space X .

Then the associated complex $\mathcal{K}(X)$ spanned by $\{v_c v_a v_b, v_d v_a v_b, v_c v_e\}$.

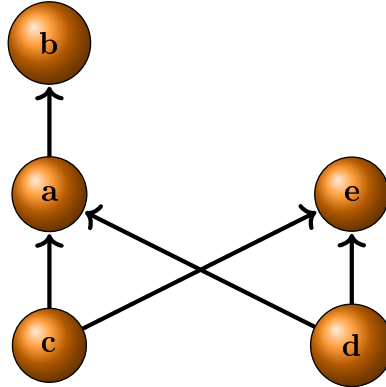

Figura 4.9: The associated simplicial complex $\mathcal{K}(X)$.

Starting with the simplicial complex $\mathcal{K}(X)$, if we want to construct the associated finite space $X' = \mathcal{X}(\mathcal{K}(X))$ for this complex, we will not have the original space X , as follows:

The simplices in the complex will be represented as points in the space X' ordered by inclusion.

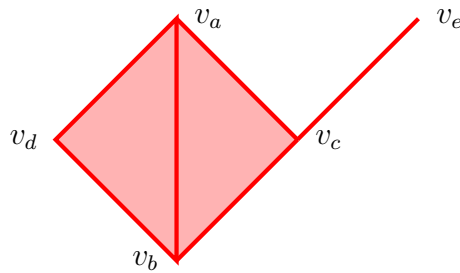

Figura 4.10: The associated finite space $\mathcal{X}(\mathcal{K}(X))$.

Theorem 4.5.2. *Let X and Y be finite T_0 -spaces.*

If $f : X \rightarrow Y$ is an order preserving map, then f induces a simplicial map $\mathcal{K}(f)$ between $\mathcal{K}(X)$ and $\mathcal{K}(Y)$ which coincides with f on vertices.

If two maps $f, g : X \rightarrow Y$ homotopic, then the simplicial maps $\mathcal{K}(f), \mathcal{K}(g) : \mathcal{K}(X) \rightarrow \mathcal{K}(Y)$ lie in the same contiguity class. In particular $|\mathcal{K}(f)|, |\mathcal{K}(g)|$ are homotopic.

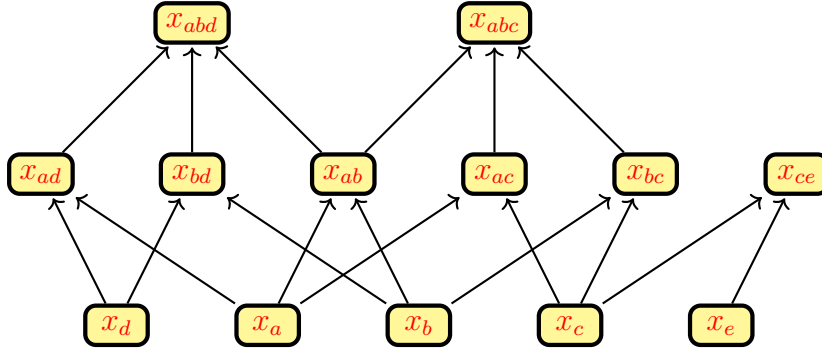
In the other direction, we have the following result.

Theorem 4.5.3. [7] *Let K and L be finite simplicial complexes.*

A simplicial map $\varphi : K \rightarrow L$ induces a continuous map $\mathcal{X}(\varphi) : \mathcal{X}(K) \rightarrow \mathcal{X}(L)$, where $\mathcal{X}(\varphi)(\sigma) = \varphi(\sigma)$ for every simplex σ of K .

Let $\varphi, \psi : K \rightarrow L$ be simplicial maps which lie in the same contiguity class. Then $\mathcal{X}(\varphi) \simeq \mathcal{X}(\psi)$.

T. Osaki [38] is the first mathematician who investigated the relationship between finite spaces and simplicial complexes with the same simple homotopy types, he proofed the following.

Theorem 4.5.4. *Let X be finite T_0 -space, if $x \in X$ is a beat point, then we can elementary collapse $\mathcal{K}(X)$.*

Moreover, if two finite T_0 -spaces, X and Y are homotopy equivalent, their associated simplicial complexes, $\mathcal{K}(X)$ and $\mathcal{K}(Y)$, have the same simple homotopy type.

Next, we show similar result for strong collapse.

Lemma 4.5.5. *Let X be finite T_0 -space, if $x \in X$ is a beat point, then we can elementary strong collapse $\mathcal{K}(X)$.*

Proof. Let $a, b \in X$, and a an up-beat point under the b , by definition for every point c comparable with a , c is also comparable with b , so if any chain C contains a , we have that $C \cup \{b\}$ also a chain.

Now let we construct the associated simplicial complex $\mathcal{K}(X)$, and Let v_a, v_b be the correspondence vertices in $\mathcal{K}(X)$ of $a, b \in X$. We have that any maximal simplex in $\mathcal{K}(X)$ (chain in X) which contains v_a also contains v_b , so v_a is dominated by v_b and $\mathcal{K}(X) \searrow \searrow \mathcal{K}(X) \setminus v_a$. \square

More relations between both concepts simplicial complexes and finite spaces will be given in next theorems.

Theorem 4.5.6. \blacksquare *If two finite T_0 -spaces X, Y are homotopy equivalent, their associated complexes $\mathcal{K}(X), \mathcal{K}(Y)$ have the same strong homotopy type.*

- \blacksquare *If two complexes K, L have the same strong homotopy type, the associated finite spaces $\mathcal{X}(K)$ and $\mathcal{X}(L)$ are homotopy equivalent*
- \blacksquare *Let K and L be two simplicial complexes. If $\mathcal{X}(K)$ and $\mathcal{X}(L)$ are homotopy equivalent, then K and L have the same strong homotopy type.*
- \blacksquare *Let X be a finite T_0 -space. Then X is a \mathcal{B} -core finite space if and only if $\mathcal{K}(X)$ is a core complex.*

Since two finite T_0 -spaces are homotopy equivalent if and only if one of them can be obtained from the other just by removing and adding beat points. Thus, the notion of \mathcal{B} -collapse of finite spaces that would follow from the notion of strong collapse coincides with the usual notion of homotopy types.

Many other results have been stated in [6], [32] and [30], which discusses more relations between a finite space X and the associated simplicial complex $\mathcal{K}(X)$ also between X and the geometric realization $|\mathcal{K}(X)|$, and visa verse.

Future work

Remark 4.5.7. *We are trying to develop more results, which will publish soon, where we are trying to generalize some results over infinite space using P -collapse concepts, instead of finite space, we discuss the following:*

1. *If we have an infinite Alexandroff space X , we discuss the existence of \mathcal{P} -core, under some conditions.*
2. *For a fixed point $a \in X$, we define the upper p -dominated point and lower p -dominated point, where both of them is unique for every point a , also we define the maximum contraction set for a point a .*
3. *we develop an algorithm to find the upper p -dominated point and the lower p -dominated point for every point $a \in X$.*
4. *In an Alexandroff space X , if a point a p^+ dominated by b with the contraction set $A_{ab}^+ = \{s : a \leq s \leq b\}$, then we discussed the relations between v_a, v_b and v_s for all $s \in A_{ab}^+$, which are the corresponding vertices in $\mathcal{K}(X)$.*

Similarly, starting with a simplicial complex K , we trying to determine the relations between points in $\mathcal{X}(K)$ corresponding to free faces and dominated vertices in K , also edges which can edge collapsed in K .

Chapter 5

Directed graph and Directed cyclic graph

5.1. Preliminaries

In this chapter we interest in a special kind of graphs called *cyclic graphs* introduced by Adamaszek, Michael, and Henry Adams [2] In their work they also state the the notion *-ve dominated vertex*. We will state a correspondence definition called *+ve dominated vertex*, and study their relations, then in section two, we will study the relations between cyclic graph and preorders and the domination in both concepts. In section three, we state some algorithms to determine cyclic graphs and determine -ve dominated vertices using the adjacency matrix of the graph.

Definition 5.1.1. [2] a directed graph is a pair $\vec{G} = (V, E)$ with V the set of vertices and $E \subseteq V \times V$ the set of directed edges. The edge (v, w) from v to w will denoted by $v \rightarrow w$, such that the edge $v \rightarrow v$ not belong to E (no loops) and if $v \rightarrow w \in E$, then $w \rightarrow v \notin E$ (no edges oriented in both directions). For a vertex $v \in V$, we denote:

$$N^+(\vec{G}, v) = \{w : v \rightarrow w\}, \quad N^-(\vec{G}, v) = \{w : w \rightarrow v\}.$$

$$N^+[\vec{G}, v] = \{w : v \rightarrow w\} \cup \{v\}, \quad N^-[\vec{G}, v] = \{w : w \rightarrow v\} \cup \{v\}.$$

Definition 5.1.2. A directed graph \vec{G} is called cyclic if its vertices can be arranged in a cyclic order $v_0 < \dots < v_{n-1}$ subject to the following condition: if there is a directed edge $v_i \rightarrow v_j$, then either $j = (i + 1) \bmod n$ or there are directed edges

$$v_i \rightarrow v_{(j-1) \bmod n} \text{ and } v_{(i+1) \bmod n} \rightarrow v_j.$$

In the future all arithmetic operations on the vertex indices are understood to be reduced modulo n ; for instance we will write simply v_{i+k} for $v_{(i+k) \bmod n}$.

Example 5.1.3. We show on the left a cycle directed graph. The graph on the middle is not cyclic neither in the order shown, nor in the $4!$ other orders generated by the same edges with changing the order in vertices. Note that it's not necessary to check all of these orders, since we can reduce these 24 orders to $4!/4$ orders because the indexes of vertices are reduced modulo $n=4$.



Figura 5.1: Cyclic and not cyclic graphs

On the right another order of vertices for the graph on the middle, but we can ignore this order, since both graphs represent the same order modulo n .

For instance, we want to denote the directed graph by \vec{G} , and use G to denote the *undirected graph* induced from \vec{G} by removing the orientations. We mean by an *induced subgraph* of a graph \vec{G} that is another graph, formed from a subset of the vertices of \vec{G} and all of the edges connecting pairs of vertices in that subset.

Lemma 5.1.4. [2] Suppose \vec{G} is a cyclic graph with n vertices in cyclic order $v_0 < \dots < v_{n-1}$. Then:

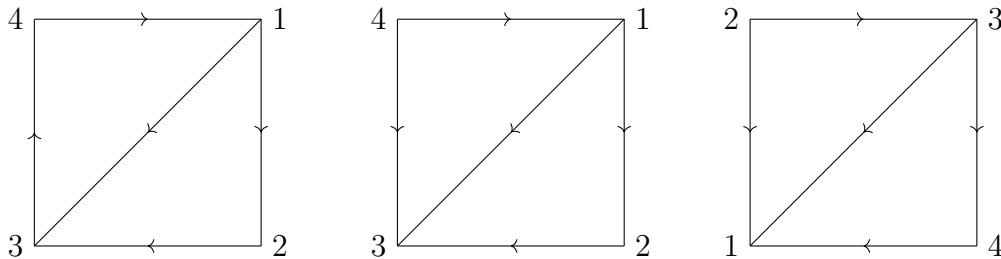
1. For every $i = 0, \dots, n-1$, there exist $p(i), e(i) \geq 0$ such that:

$$N^+(\vec{G}, v_i) = \{v_i, v_{i+1}, \dots, v_{p(i)}\}, \quad N^-(\vec{G}, v_i) = \{v_{e(i)}, \dots, v_{i-1}, v_i\}.$$

2. For every $i = 0, \dots, n-1$, we have inclusions

$$N^+(\vec{G}, v_i) \subseteq N^+(\vec{G}, v_{i+1}), \quad N^-(\vec{G}, v_{i+1}) \subseteq N^-(\vec{G}, v_i)$$

3. Every induced sub-graph of \vec{G} is a cyclic graph.
4. If \vec{G} contains a directed cycle then $v_i \rightarrow v_{i+1}$ for all $i = 0, \dots, n-1$.

Next we show that each of condition 1 and 2 in the previous lemma is equivalent to let \vec{G} be cyclic.

Proposition 5.1.5. The following are equivalent:

- \vec{G} is cyclic.
- Condition (1) in Lemma 5.1.4.
- Condition (2) in Lemma 5.1.4.

Proof.

- If \vec{G} is cyclic, then condition(1) and condition (2) follow directly from the definition
- Suppose that condition(1) holds, such that for every $i = 0, \dots, n-1$, there exist $p(i), e(i) \geq 0$ such that:

$$N^+(\vec{G}, v_i) = \{v_i, v_{i+1}, \dots, v_{p(i)}\}, \quad N^-(\vec{G}, v_i) = \{v_{e(i)}, \dots, v_{i-1}, v_i\}$$

First, it is possible to order all vertices in \vec{G} using the orders over each $N^+[v_i]$ for all i together.

Let $v_i \rightarrow v_j$ in a directed graph \vec{G} . Since $v_j \in N^+[\vec{G}, v_i]$, so $j = i + t$ such that $i < i + t \leq p(i)$. If $t = 1$, then it is done.
If $t > 1$, then $i < i + t - 1 \leq p(i) - 1 < p(i)$, so

$$v_{j-1} = v_{i+t-1} \in N^+[\vec{G}, v_i],$$

and $v_i \rightarrow v_{j-1}$. Similarly, since $v_i \in N^-[\vec{G}, v_j]$, we get that $j = i + 1$ or $v_{i+1} \rightarrow v_j$. So \vec{G} is cyclic.

- Suppose that condition(2) satisfies, such that for every $i = 0, \dots, n - 1$, we have inclusions

$$N^+(\vec{G}, v_i) \subseteq N^+[\vec{G}, v_{i+1}], \quad N^-(\vec{G}, v_{i+1}) \subseteq N^-(\vec{G}, v_i)$$

after ordering the vertices in V , let $v_i \rightarrow v_j$ in a directed graph \vec{G} . If $j = i + 1$, then it's done. If $j - 1 \neq i$, then

$$v_j \in N^+(\vec{G}, v_i) \subseteq N^+[\vec{G}, v_{i+1}],$$

so $v_{i+1} \rightarrow v_j$. Also

$$v_i \in N^-(\vec{G}, v_j) \subseteq N^-(\vec{G}, v_{j-1}),$$

so $v_i \rightarrow v_{j-1}$, and \vec{G} is cyclic. □

So we can use the two conditions to characteristic the cyclic graph.

Lemma 5.1.6. *If we have that $i < j < k$ and $v_i \rightarrow v_k$, then $v_i \rightarrow v_j \rightarrow v_k$.*

Proof. Since $v_k \in N^+[v_i] = \{v_i, v_{i+1}, \dots, v_j, \dots, v_k, \dots\}$, then $v_i \rightarrow v_j$, similarly $v_i \in N^-[v_k]$, so $v_j \rightarrow v_k$. □

Definition 5.1.7. *Suppose \vec{G} is a cyclic graph with vertex ordering $v_0 < \dots < v_{n-1}$.*

1. A vertex v_i is called +ve dominated by v_{i-1} (or just +ve dominated) if

$$N^+[\vec{G}, v_i] = N^+(\vec{G}, v_{i-1}).$$

2. A vertex v_i is called -ve dominated by v_{i+1} (or just -ve dominated) if $N^-[\vec{G}, v_i] = N^-(\vec{G}, v_{i+1})$.

In [2] the authors defined the -ve dominated vertex, and we state the definition of +ve dominated vertex. In the following we will proof that both of those definitions are correlative.

Example 5.1.8. For the cyclic graph shown, we have v_2 is +ve dominates by v_1 and v_2 is -ve dominates by v_3 .



Figura 5.2: Cyclic graph includes a +ve and -ve dominated vertex.

We denote the induced sub-graph generates by removing a vertex v from a graph \vec{G} by $\vec{G} - v$.

And If v_i is +ve dominated by v_{i-1} , we denote $\vec{G} \setminus v_i$ the graph removing v_i vertex from the cyclic graph \vec{G} by the map $f : \vec{G} \rightarrow \vec{G} \setminus v_i$, given by:

$$f(v_j) = \begin{cases} v_j & j \neq i \\ v_{i-1} & j = i. \end{cases}$$

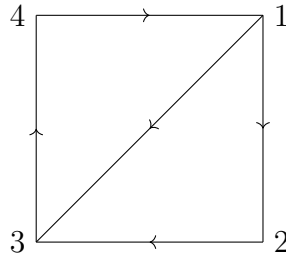
We re-arrange the cyclic order of the vertices in the new graph $\vec{G} \setminus v_i$ for all $k \geq i$, such that the order over $\vec{G} \setminus v_i$ vertices is inherit from the order over $V(\vec{G})$ and f preserve the order.

The graph $\vec{G} \setminus v_{i+1}$ is an induces sub-graph so using Condition (3) in Lemma 5.1.4, $\vec{G} \setminus v_i$ is also a cyclic graph. Similarly for -ve dominated vertices.

Proposition 5.1.9. If \vec{G} is a cyclic graph, then:



There exist a -ve dominated vertex \Leftrightarrow There exist a +ve dominated vertex.

Moreover, the number of +ve dominated vertices is equal to the number of -ve dominated vertices in \vec{G} .

Proof. Let v_i be -ve dominated by v_{i+1} , so $N^-[\vec{G}, v_i] = N^-(\vec{G}, v_{i+1})$. By Lemma 5.1.4 for any $j = 0, \dots, n-1$, $N^+[\vec{G}, v_j] = \{v_j, v_{j+1}, \dots, v_{p(j)}\}$, where $p(j) \in \{0, \dots, n-1\}$.

Since $\forall v, v \rightarrow v_i$ then $v \rightarrow v_{i+1}$, there is no vertex v_j such that $p(j) = i$.

Then $|\{p(j) : v_j \in G\}| < |V(G)|$. So $\exists v_l, v_r$ such that $p(l) = p(r)$; let it call $*$.

Assume without loss of generality $l < r$, then by Lemma 5.1.6,

$$N^+[\vec{G}, v_l] = \{v_l, \dots, v_r, \dots, v_*\}, \quad N^+[\vec{G}, v_r] = \{v_r, \dots, v_*\}.$$

Now it's easy to show that for any element v_j such that $l \leq j-1 < j \leq r$, we have $N^+[\vec{G}, v_j] = \{v_j, \dots, v_*\}$.

Hence $N^+[\vec{G}, v_j] = N^+(\vec{G}, v_{j-1})$, that is v_{j+1} +ve dominated by v_j when $l \leq j-1 < j \leq r$.

Similarly, if we have a +ve domination vertex we can construct a -ve domination.

Secondly, we should minimize the graph through finite steps -since V is finite- by removing in each step a one +ve dominated vertices v_i together with a one -ve dominated vertices corresponding to v_i . In each step we get a new induced subgraph which is also cyclic.

Claim: Let the vertex v_i +ve dominated by v_{i-1} in \vec{G} . And for $j \neq i, \text{ mod } n$, let the vertex v_j is also +ve dominated in \vec{G} . Then after removing the vertex v_i from \vec{G} , the vertex v_j is still +ve dominated in the induced subgraph $\vec{G} \setminus v_i$.

To show this, it is enough to test the case when $j = i+1$, where we have in \vec{G} that:

The vertex v_i +ve dominated by v_{i-1} , so $N^+[\vec{G}, v_i] = N^+(\vec{G}, v_{i-1})$.

And $v_j = v_{i+1}$ +ve dominated by v_i , so $N^+[\vec{G}, v_{i+1}] = N^+(\vec{G}, v_i)$. So

$$N^+[\vec{G}, v_{i+1}] = N^+(\vec{G}, v_i) = N^+[\vec{G}, v_i] - v_i = N^+(\vec{G}, v_{i-1}) - v_i$$

Now after collapsing v_i and reorder the indices of vertices in $\vec{G} \setminus v_i$, the vertex v_{i+1} will be the i th vertex, and we have :

$$N^+[\vec{G} \setminus v_i, v_i] = N^+(\vec{G} \setminus v_i, v_{i-1})$$

So, the number of +ve dominated vertices is equal to the number of -ve dominated vertices in \vec{G} . \square

The undirected graph is actually a 1-dimension simplicial complex.

Definition 5.1.10. [52] In an undirected graph G , and a two vertices v, w we denote $v \sim w$ if they are connected with an edge in G , and we denote $N[v] = \{u : v \sim u\} \cup \{v\}$.

We say, the vertex v dominated by the vertex w , if $N[v] \subseteq N[w]$.

In the directed cyclic graph, using the order over vertices it will be easy to check if the graph have any dominated vertices or it's a minimal graph. Since it's enough to check if v_i dominates only the next vertex v_{i+1} but in the undirected graph we need to check every vertex v with all vertices in $N[v] - \{v\}$.

Lemma 5.1.11. If v is +ve or -ve dominated vertex in a cyclic graph \vec{G} , then v is dominated vertex in G .

Proof. If v_{i+1} is +ve dominate by v_i , then $N^+[\vec{G}, v_{i+1}] = N^+(\vec{G}, v_i)$.

Also by Lemma 5.1.4, $N^-(\vec{G}, v_{i+1}) \subseteq N^-(\vec{G}, v_i)$.

So $N[G, v_{i+1}] = N^+[\vec{G}, v_{i+1}] \cup N^-(\vec{G}, v_{i+1}) \subseteq N[G, v_i]$ \square

The converse of the Lemma is not true as we show in the following two examples.

Example 5.1.12. This counter example shows that if we have the cyclic graph $v_1 \rightarrow v_2 \rightarrow v_3 \rightarrow v_1$ as a directed cycle graph. The undirected graph G contains a dominated vertices. But \vec{G} dose not contain any dominated vertices, because for all $i = 1, 2, 3$, we have $|N^+[\vec{G}, v_{i+1}]| = 2$ and $|N^+(\vec{G}, v_i)| = 1$.

Also if \vec{G} is not a cyclic graph containing a +ve or -ve dominate vertex, it is not necessary for this vertex to be dominate in the undirected graph.

Example 5.1.13. *The following graph is not cyclic, since $N^+(1) \not\subseteq N^+[2]$ (using the second equivalent characteristic for cyclic graph).*



Figura 5.3: Not cyclic graph.

Now, $N^-[\vec{G}, 1] = \{1, 3\}$, $N^-[\vec{G}, 2] = \{1, 3\}$, so 1 is -ve dominated by 2 in \vec{G} . But in G , we have that $N[1] = \{1, 2, 3, 4\} \not\subseteq N(2)$.

Definition 5.1.14. [2] Suppose \vec{G} and \vec{H} are cyclic graphs, and a vertex map $f: \vec{G} \rightarrow \vec{H}$.

We say f is a homomorphism of directed graphs, if for every edge $v \rightarrow w$ in \vec{G} either $f(v) = f(w)$ or there is an edge $f(v) \rightarrow f(w)$ in \vec{H} .

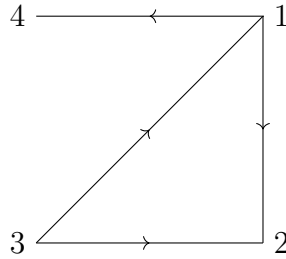
Lemma 5.1.15. If \vec{G} is a cyclic graph and v_i is +ve dominated by v_{i-1} , then the map $f: \vec{G} \rightarrow \vec{G} \setminus v_i$, given by:

$$f(v_j) = \begin{cases} v_j & j \neq i \\ v_{i-1} & j = i. \end{cases}$$

is a homomorphism of directed graphs. The composition $\vec{G} \setminus v_i \hookrightarrow \vec{G} \xrightarrow{f} \vec{G} \setminus v_i$ is the identity.

Example 5.1.16. For the following cyclic graph \vec{G} in the middle, we have v_3 is -ve dominated by v_4 also v_3 is +ve dominated by v_2 , so we can remove v_3 in both cases. And by previous lemma, the composition $\vec{G} \setminus v_3 \hookrightarrow \vec{G} \xrightarrow{f} \vec{G} \setminus v_3$ is the identity.



Figura 5.4: Cyclic graph with a dominated vertex.

On the left $\overrightarrow{G - v_3}$, on the middle \overrightarrow{G} , on the right $f(\overrightarrow{G}) = \overrightarrow{G} \setminus v_3$.

In general, If the vertex v_i is not a dominated vertex, So it is not true that the composition $\overrightarrow{G - v_i} \hookrightarrow \overrightarrow{G} \xrightarrow{f} \overrightarrow{G} \setminus v_i$ is the identity. We state the following counter example.

Example 5.1.17. For this cyclic graph \overrightarrow{G} , the composition $\overrightarrow{G - v_3} \hookrightarrow \overrightarrow{G} \xrightarrow{f} f(\overrightarrow{G})$ is not the identity.

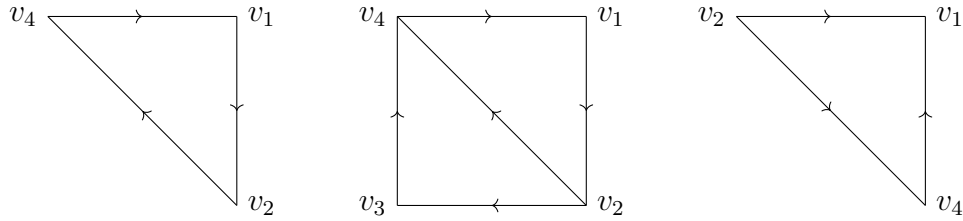

Figura 5.5: Cyclic graph without dominated vertices.

On the left $\overrightarrow{G - v_3}$, on the middle \overrightarrow{G} , and on the right $f(\overrightarrow{G})$.

Remark 5.1.18. Let \overrightarrow{G} be a cyclic graph, such that v_{i+1} is +ve dominated by v_i in \overrightarrow{G} , Then \overrightarrow{G} contains at least four vertices.

If \vec{G} consists of 3 vertices, as we shown in Example 5.1.12, this cyclic graph $v_1 \longrightarrow v_2 \longrightarrow v_3$, could not contain both any +v or -ve dominated vertices v_i . Also we will avoid the following oriented edges in $\vec{G} \setminus v_i$:

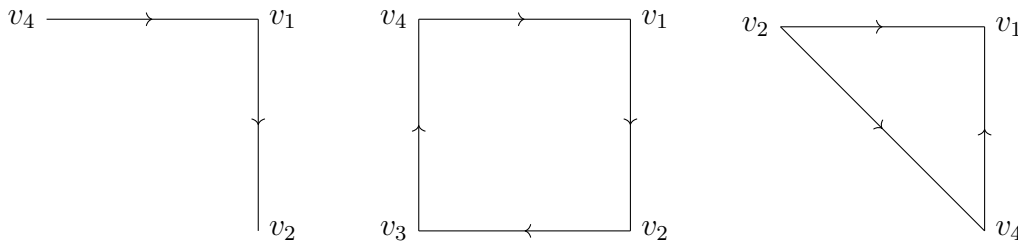
$$\begin{array}{c} v_{i-1} \longrightarrow v_i \longrightarrow v_{i+1} \longrightarrow v_{i-1} \\ \downarrow f \\ v_{i+1} \longleftarrow v_{i-1}. \end{array}$$

So \vec{G} contains at least 4 different vertices, and the image of f will contain at least 3 vertices, (without oriented edges).

5.2. Relationship between directed graphs and preorders

If we have a finite directed graph $\vec{G} = (V, E)$, we can construct a binary relation \leq over V , by *reachability*, that means $v \leq w$ if we can start at the vertex v and reach the vertex w through a sequence of edges $v \rightarrow \dots \rightarrow w$ in \vec{G} (a path), and we denote $v \leq w$ by $v \rightsquigarrow w$.

This relation is reflexive since we can reach the vertex from itself by zero edges, and transitive by reachability, so it is a preorder, denote it by $X(\vec{G}) = (V, \leq)$, where the set of points in $X(\vec{G})$ is the same of the set of vertices in \vec{G} which is V .

Recall a path forms a cycle if the starting vertex of its first edge equals the ending vertex of its last edge.

If \vec{G} have no cycle so the reachability \rightsquigarrow is antisymmetric and we have that $X(\vec{G})$ is a poset.

Now we study some relations between \vec{G} and $X(\vec{G})$.

Lemma 5.2.1. *Let \vec{G} be a cyclic graph with vertex ordering $v_0 < \dots < v_n$. If $i \leq j \leq k$, and $v_i \rightsquigarrow v_k$ in $X(\vec{G})$, then $v_i \rightsquigarrow v_j \rightsquigarrow v_k$.*

Proof. We have that $v_i \rightsquigarrow v_k$, so there is a set of vertices $W = \{v_{i_t} : 0 \leq t \leq r\} \subseteq \vec{G}$, with a sequence of edges such that:

$$v_i = v_{i_0} \rightarrow \dots v_{i_t} \rightarrow v_{i_{t+1}} \rightarrow \dots \rightarrow v_{i_r} = v_k$$

If $v_j = v_{i_t}$ for some t , done.

If not, and since $i \leq j \leq k$, so we can find an index t such that

$$i \leq i_t \leq j \leq i_{t+1} \leq k$$

and v_t, v_{t+1} belongs to W , represent the ends vertices for an edge in this path $v_i \rightsquigarrow v_k$.

Now we have $v_{i_t} \rightarrow v_{i_{t+1}}$ and $i_t \leq j \leq i_{t+1}$. Apply Lemma 5.1.6 we get

$$v_i = v_{i_0} \rightarrow \cdots \rightarrow v_{i_t} \rightarrow v_j \rightarrow v_{i_{t+1}} \rightarrow \cdots \rightarrow v_{i_r} = v_k$$

So $v_i \rightsquigarrow v_j \rightsquigarrow v_k$. □

Theorem 5.2.2. *If \vec{G} is a connected directed cyclic graph, then $X(\vec{G})$ can P -collapse to a point.*

Proof. For any v_i, v_j , such that $v_i \leq v_j$, let $v_k \geq v_i$, By the order on V and the previous lemma,

if $j \leq k$ then $v_i \rightsquigarrow v_j \rightsquigarrow v_k$, so $v_j \leq v_k$.

If $k \leq j$ we have $v_i \rightsquigarrow v_k \rightsquigarrow v_j$, and $v_k \leq v_j$.

So $v_k \rightsquigarrow v_j$ and v_i is p^+ dominated by v_j . Now by connectedness of \vec{G} , all points in $X(\vec{G})$ can P -collapse to a point. □

Moreover, if \vec{G} contains a directed cycle, so by Lemma 5.1.4. $v_i \rightarrow v_{i+1}$ for all i , and hence each v_i is an up-beat point in $X(\vec{G})$.

As an example, the cyclic graph \vec{G} contains of two vertices and no edge, is not connected graph, and generates the preorder space $X(\vec{G})$ which is not P -collapsible space.

In the other direction, if we have a poset (X, \leq) , we can construct a directed graph $\vec{G}(X)$ where the set of vertices equal X such that $v \rightarrow w$ if $v \leq w$. And $v = w$ in $\vec{G}(X)$ if $v = w \in X$ to a void the existence of a loop.

We suppose that X should be a poset, since the antisymmetric property grants that $\vec{G}(X)$ do not include an oriented edges in both direction. So every

poset can generate a directed graph.

Moreover, this directed graph have no directed cycle, suppose we have a cycle $v \rightarrow \dots \rightarrow w \rightarrow \dots \rightarrow v$ in $\vec{G}(X)$, that mean $v \leq \dots \leq w \leq \dots \leq v$ in X , by transitivity of \leq we have $v \leq w$ and $w \leq v$, by antisymmetric $v = w$ in X , so both X and $\vec{G}(X)$ contain of a single element.

If we want to construct a directed cyclic graph over a finite poset (X, \leq) , then the vertices in X needed to be arranged in a cyclic order v_0, v_1, \dots . So first we will order the set X , and show that the directed graph $\vec{G}(X)$ with this order on the vertices generates a directed cyclic graph.

For a poset (X, \leq) , construct a linear order $<$ on X , such that

- For any $x, y \in X$, $x \leq y$ implies $x = v_i$ and $y = v_j$ such that $i < j$
- For any $i < k < j$, $v_i \leq v_j$ implies that $v_i \leq v_k \leq v_j$.

Theorem 5.2.3. *Let (X, \leq) be a finite poset. The directed graph $\vec{G}(X)$ with the previous order over X is cyclic.*

Proof. Let $v_i \rightarrow v_j$ be a directed edge in $\vec{G}(X)$, so $v_i \leq v_j$ in X where $i < j$. If $j = i + 1$ done.

If not we have $i < k < j$ for some k , and so, $v_i \leq v_k \leq v_j$. Since X is finite we can repeat this step finitely repetition to get the chain $v_i \leq v_{i+1} \leq \dots \leq v_{j-1} \leq v_j$ in X , implies $v_i \leq v_{j-1}$ and $v_{i+1} \leq v_j$. Now, since $i \neq j + 1$ we have $v_i \rightarrow v_{j-1}$ and $v_{i+1} \rightarrow v_j$, so $\vec{G}(X)$ is cyclic. \square

The directed graph \vec{C}_n^k

Definition 5.2.4. *For integers n and k , with $0 \leq 2k < n$, the directed graph denote \vec{C}_n^k , whose has a vertex set $\{v_0, \dots, v_{n-1}\}$, and edges $v_i \rightarrow v_{(i+s)}$ for all $i = 0, \dots, n-1$ and $s = 1, \dots, k$.*

Also define the undirected graph C_n^k with $0 \leq k < n$ and edges $v_i \sim v_{(i+s)}$ with $s = 1, \dots, k$.

We have three cases as follows:

case 1. If $2k + 1 > n$, we could not construct the directed graph \overrightarrow{C}_n^k since we have edges oriented in both direction.
 But we construct C_n^k , and all vertices are all-to-all connected, so every two consequence vertices dominates each other.
 If we remove one dominated vertex, we generate C_{n-1}^k , but $2k + 1 > n > n - 1$, so we can dominate more vertices, we continue until we have a vertex graph.

case 2. If $2k + 1 = n$, we can construct \overrightarrow{C}_n^k , and this directed graph is cyclic and dose not contain any +ve or -ve dominated vertices, because for all i , $|N^+(\overrightarrow{G}, v_{i+1})| = k + 1$, and $|N^+(\overrightarrow{G}, v_i)| = k$.
 But the undirected graph C_n^k contains dominated vertices because for all i , $N[v_i] = \{v_{i-k}, \dots, v_i, \dots, v_{i+k}\}$ so $|N[v_i]| = 2k + 1 = n = |C_n^k|$, and thus all vertices are all-to-all connected. As case 1. we can continue removing points until we reach a single vertex graph.

case 3. If $2k + 1 < n$, then both \overrightarrow{C}_n^k and C_n^k will not have any dominated vertices (in this case the graph is called as a *minimal graph or a core*).
 Similarly as Case 2. we can proof that \overrightarrow{C}_n^k is minimal graph.
 Also the undirected graph C_n^k is minimal, since $v_{i-k} \notin N[v_{i+1}] \forall i$, and hence

$$N[v_i] = \{v_{i-k}, v_{i+1-k}, \dots, v_i, \dots, v_{i+k}\} \not\subseteq N[v_{i+1}] = \{v_{i+1-k}, \dots, v_i, v_{i+1} \dots, v_{i+1+k}\}.$$

It is easy to proof the following Lemma.

Lemma 5.2.5. *Let \overrightarrow{G} be a cyclic graph*

(a.) *If $\forall i, |N^+(\overrightarrow{G}, v_i)| = k$, where k is a constant, then $\overrightarrow{G} \cong \overrightarrow{C}_{|G|}^k$*

(b.) *If $\forall i, |N^-(\overrightarrow{G}, v_i)| = k$, where k is a constant, then $\overrightarrow{G} \cong \overrightarrow{C}_{|G|}^k$*

Definition 5.2.6. *We say a cyclic graph \overrightarrow{G} dismantles to an induced subgraph \overrightarrow{H} if there is a sequence of graphs $\overrightarrow{G} = \overrightarrow{G}_0, \overrightarrow{G}_1, \dots, \overrightarrow{G}_s = \overrightarrow{H}$ such that \overrightarrow{G}_i is obtained from \overrightarrow{G}_{i-1} by removing a +ve or -ve dominated vertex for $i = 1, \dots, s$.*

In next proposition, The first statement (a.) is proved in [2], we will generalise it for the +ve dominated vertices in (b.), then we show the relation in (c.).

Proposition 5.2.7. *Let \vec{G} be a cyclic graph*

- (a.) \vec{G} without -ve dominated vertex is isomorphic to \vec{C}_n^k for some $0 \leq 2k < n$. As a consequence, every cyclic graph dismantles to an induced subgraph of the form \vec{C}_n^k . [2],
- (b.) \vec{G} without a +ve dominated vertex is isomorphic to \vec{C}_m^l for some $0 \leq 2l < m$. As a consequence, every cyclic graph dismantles to an induced subgraph of the form \vec{C}_m^l .

Since the number of +ve dominated vertices is equal to the number of -ve dominated vertices as we shown in Proposition 5.1.9, so we have $n = m$.

5.3. Adjacency matrix and algorithms

We can represent any graph by an adjacency matrix with entry $(i, j) = 1$ when the vertex $i \rightarrow j$, and zero entries elsewhere. So the row i show all vertices j such that $i \rightarrow j$ and the column j show all vertices i such that $i \rightarrow j$. Now we want to answer the following:

- Q1 If we have a graph with an order on it vertices, how we can detect if this order yield to a cyclic graph by using the adjacency matrix?
- Q2 How we can determine the dominated vertices in a cyclic graph using the adjacency matrix?

If we have an adjacency matrix represent a directed graph $\vec{G} = (V, E)$ with n ordered vertices, and we want to check if the chosen order -represented in this matrix- will give us a cyclic graph, the matrix should agree with the following:

1. For any row say i , the entry (i, i) must be zero.

2. If there exist 1's in row i , this 1's must start from the second entry $(i, i + 1)$, since if the vertex i go to some other vertices then firstly it must go to the vertex $i + 1$.
3. When we permute this row to start from the first one in the entry $(i, i+1)$, all 1's must be consecutive (without gabs)

Similar way for every column.

The proof depends on Proposition 5.1.5 that gives the following characteristic for cyclic graph \vec{G}

For every $i = 0, \dots, n - 1$, there exist $p(i), e(i) > 0$ such that:

$$N^+[\vec{G}, v_i] = \{v_i, v_{i+1}, \dots, v_{p(i)}\}.$$

$$N^-[\vec{G}, v_i] = \{v_{e(i)}, \dots, v_{i-1}, v_i\}.$$

The result about rows follows from the first equation, and the result about columns follows from the second equation.

Next we state an algorithm to translate this result and determine if an adjacency matrix can represent a cyclic graph or not.

Algorithm 5: Determine if an adjacency matrix can represent a cyclic graph

Data: Adjacency matrix M of a directed graph

```

1  $n$  = number of rows in  $M$ 
2 initialize  $i = 0$ 
3 Error = 0
4 while  $i < n$  and Error = 0 do
5    $N^+[i] = \{j : M(i, j) \neq 0\}$ 
6    $p[i] = \text{Length } N^+[i]$ 
7   if  $p[i] > 0$  // Test: the  $i$ -th row satisfy the cyclic condition
8   then
9     for ( $j \in \{1, \dots, p[i]\}$ ) {
10      Let  $t = (i + j) \% n$  // modulo  $n$ 
11      if  $M[i, t] \neq 1$  then
12        Error = Error + 1
13      end
14    }
15     $i = i + 1$ 
16  else
17     $i = i + 1$ 
18  end
19 end

```

Result: \vec{G} is cyclic or not cyclic

```

20 if Error = 0 then
21   Print( $\vec{G}$  is a cyclic graph)
22 else
23   Print( $\vec{G}$  is not a cyclic graph)
24 end

```

We can make changes on the matrix to generate a cyclic graph by adding 1's in some entries to fill the gaps as we show in the next example.

Example 5.3.1. *In this matrix we can observe that it can't represent a cyclic graph for two reasons.*

Row 1, which is (0, 1, 0, 1) have a non consecutive 1's.

Row 2, which is (0, 0, 1, 0), the first 1 not in the entry (i, i + 1).

But we can convert this matrix to represent a cyclic graphs by filling both red gaps by ones.

end point	1	2	3	4
start point				
1	0	1	0	1
2	0	0	0	1
3	1	0	0	1
4	0	0	0	0

Cuadro 5.1: Adjacency matrix.

To answer Question 2. and if we have a adjacency matrix represent a directed graph without ordering it's vertices, we want to rewrite this matrix to detect if there is an order over the vertices makes the graph cyclic Through the following algorithm, first we select any vertex to be the first one in the new order, we can start with an arbitrary vertex since the order is modulo n. We will search in $N^+(v)$ for the next vertex by test which vertex $w \in N^+(v)$ is the next one, that's happens if:

$$|N^+(v) \cap N^+(w)| = |N^+(v)| - 1$$

This clear from Proposition 5.1.5 because $N^+(v) \subseteq N^+[w]$, if v is the followed directly by w in the order.

Then we repeat this steps to trying order all vertices, otherwise we will have an Error.

If we success to order all the vertices, then we will apply Algorithm 1. to check if the new order over the vertices represent a cyclic graph

Algorithm 6: Reorder a adjacency matrix to check if it can represent a directed cyclic graph. **Main Part.**

Result: Determine a matrix have a cyclic order?

Data: Adjacency matrix M of a graph.

- 1 Set Vertices = all vertices of the graph in the original positions.
- 2 Denote $O(x)$ to be the new position of the vertex x .
- 3 Set $N^+(x) = \{y : M[x, y] = 1\}$
- 4 Set $N^-(x) = \{y : M[y, x] = 1\}$
- 5 Pick $v \in Vertices$ // to start with it
- 6 Set $O(v) = 0$ // We can permute the order mod n to start with an arbitrary vertex.
- 7 Let $x = v$
- 8 **while** x in Vertices **do**
- 9 **if** $N^+(x) \neq \phi$ **then**
- 10 | Apply Function Search in the row x .
- 11 **end**
- 12 | // If we do not find yet the next vertex and Vertices didn't
- 13 | change
- 14 | **if** $N^-(x) \neq \phi$ **then**
- 15 | | Apply Function Search in the column x
- 16 | **end**
- 17 **end**
- 18 **if** Vertices = ϕ **then**
- 19 | Print {all vertices are ordered}.
- 20 **else**
- 21 | Print {Errorr. This matrix cannot represent a cyclic graph}.
- 22 **end**

23 Now apply Algorithm 5 . to check if this matrix over the new order represent a cyclic graph empty from gaps and permutation of edges

Algorithm 7: Reorder an adjacency matrix to check if it represent a directed cyclic graph **Function 1.**

Result: Reordering the vertices in a cyclic order.

Data: Adjacency matrix M

```

/* We search in row x for the next vertices i,e finding  $v, x \rightarrow v$ . */
25 Function Search in the row  $x$  ( $x, Vertices, O$ ):
26   Original( $x$ ) =  $x$ ;
27   Let  $t = O(x)$ ;
28   Let  $N = N^+(x)$ ;
29   for (  $v$  in  $N$  and  $v$  not in  $Vertices$  // to avoid ordering a vertex
        ordered before and to break the loop.
30   ) {
31     Is  $|N \cap N^+(v)| == |N| - 1$ ;
32     if yes then
33       |  $O(v) = t + 1$  // ordering  $v$ .
34       |  $Vertices = Vertices - \{v\}$  // So  $v$  will not ordered again.
35       |  $x = v$  // Change  $x$  to  $v$ 
36       |  $N = N^+(x)$  // we will search for the next vertex of the
        new  $x$ .
37       | Repeat the For loop from the beginning with the new data;
38     else
39       | Complete the for loop to test the next  $v$ .
40   if  $Vertices = \phi$  // all vertices ordered
41     then
42       | Break.;
43     else
44       | Set  $x = Original(x)$  // Then we will test the previous element
        of  $x$  in the next step, i,e finding  $v, v \rightarrow x$ .
45   return  $x, Vertices, O$ ;

```

Algorithm 8: Reorder an adjacency matrix to check if it represent a directed cyclic graph Function 2.

Result: Reordering the vertices in a cyclic order.

Data: Adjacency matrix M .

```

/* Now, we are trying to order vertices in the column of x          */
25 Function Search in the row  $x$  ( $x$ ,  $Vertices$ ,  $O$ ):
26   Let  $t = O(x)$ ;
27   Let  $N = N - (x)$ ;
28   for (  $v$  in  $N$  and  $v$  not in  $Vertices$  // To avoid ordering a vertex
        ordered before and to break the loop.
29   ) {
30     Is  $|N \cap N^-(v)| == |N| - 1$ ;
31     if yes then
32        $O(v) = t - 1$  // ordering  $v$ .
33        $Vertices = Vertices - \{v\}$  // So  $v$  will not ordered again.
34        $x = v$  // Change  $x$  to  $v$ .
35        $N = N^-(x)$  // We will search for the next vertex of the
        new  $x$ .
36       Repeat the For loop from the beginning with the new data;
37     else
38       Complete the for loop to test the next  $v$ ;
39       Break, if  $Vertices = \phi$  // all vertices ordered.
40   return  $x$ ,  $Vertices$ ,  $O$ ;

```

To answer the third question. Firstly, we will detect if an adjacency matrix of cyclic graph contain a +ve or -ve dominated vertices, then we will dismantle the cyclic graph

We will check if two consequence rows $i, i - 1$ have their last ones lying in the same column, then we have that the vertex i is +ve dominated by the vertex $i - 1$, and we remove i from \vec{G} .

$$N^+[\vec{G}, i] = N^+(\vec{G}, i - 1)$$

Or we will check if two consequence columns $i, i + 1$ have their first ones lying in the same row, then we have that the vertex i is -ve dominated by the vertex $i + 1$, and we remove i from \vec{G} .

$$N^-[\vec{G}, i] = N^-(\vec{G}, i + 1)$$

So if we want to detect the +ve dominated points, we check the rows. And to test the -ve dominated point, we check the column.

Secondly, we will dismantle the graph, for example if we find a vertex v_i +ve dominated vertices by v_{i-1} we will delete the i-th row.

Also we will delete the i-th column, we can do this because $N^-(\vec{G}, i) \subseteq N^-[\vec{G}, i - 1]$.

start \ end point	a	b	c	d	f
a	0	1	0	0	0
b	0	0	1	1	0
c	0	0	0	1	0
d	0	0	0	0	1
f	1	0	0	0	0

Cuadro 5.2: Adjacency matrix.

Example 5.3.2. In Table 2, the vertex c +ve dominated by b since the last ones in both c row and b row lies on the same column.

The column c, d start their one's entry at the same rows, so c -ve domination

by d .

We dismantle the graph by removing the point c , so we delete the column and the row label with c .

Algorithm 9: How to determine the dominated vertices in a directed cyclic graph and then minimise the graph

```

/* Detect the +ve dominated vertices by check the rows */
Result: Determine  $\vec{C}_n^k$  by dismantles  $\vec{G}$ 
Data: Adjacency matrix  $M$  of a directed cyclic graph
1  $n =$  number of rows in  $M$ 
2 Set  $i = 0$  // counter for rows
3
4 for (  $i \in [0, n]$  ) {
5    $N[i] = \{j : M(i, j) \neq 0\}$ 
6    $L[i] = \text{Length } N[i]$ 
7   if  $L > 0$  then
8      $M[(i + 1) \bmod n, (i + L[i] + 1) \bmod n] = 0$  // finding a
       dominated vertex
9     Print ( $i + 1$  is +ve dominated by  $i$ )
10    Redefine  $M$  by deleting row  $i + 1$  and column  $i + 1$  // minimize
       the matrix
11     $i = i$  // To check the vertex  $i$  with its new next vertex in the
       new matrix
12  else
13     $i = i + 1$ 
14  end
15 }
16  $k = L[0]$  // Now, the Length for all rows is the same.
17  $\vec{G}$  dismantles to an induced sub graph of the form  $\vec{C}_n^k$ 

```

Listings

2.1. Algorithm 1. Strong collapse algorithm.	36
2.2. Example: Partition the maximal set of simplicial complex	39
2.3. Edge collapse Algorithm. Example 1	54
2.4. Edge collapse Algorithm. Example 2	56
2.5. Algorithm 2. Edge collapse algorithm	57
3.1. Examples of matroids	70
3.2. Test a collection is a matroid	72
3.3. Algorithm 3. Test if a matroid is a core	72
3.4. Finding the famous points.	79
3.5. Algorithm 4. Partition of matroid base	80
3.6. Example 1. Partition of matroid base.	81
3.7. Example 2. Partition of matroid base	82

List of Figures

1.1. Simplicial complex.	3
1.2. Geometric realization of a simplicial complex	8
1.3. Simplicial complex.	9
1.4. Bing's house with two rooms.	14
2.1. Collapse a simplicial complex	25
2.2. Strong collapse a simplicial complex	28
2.3. Strong collapse algorithm, part 1.	33
2.4. Strong collapse algorithm, part 2.	34
2.5. Collapse but not edge collapse.	42
2.6. Edge collapse but not strong collapse.	43
2.7. Edge collapse algorithm, part 1.	49
2.8. Edge collapse algorithm, part 2.	50
2.9. Edge collapse algorithm, part 3.	51
2.10. Edge collapse algorithm, part 4.	52
2.11. Edge collapse algorithm, part 5.	53
3.1. Simplicial complex (matroid) can be edge collapsed but not collapse nor strong collapse.	75
4.1. Hasse diagram	98
4.2. Infinite space which is a finite-chain space	99
4.3. P -collapsible, but not B^+ -collapsible space.	103
4.4. P -collapsible and B^+ -collapsible space.	104
4.5. P -collapsible space with no elementary B^+ -collapse	105
4.6. Finite bounded but not fp-space.	109



4.7. \mathcal{B} -core and \mathcal{P} -core space	111
4.8. Finite Alexandroff space X	115
4.9. The associated simplicial complex $\mathcal{K}(X)$	115
4.10. The associated finite space $\mathcal{X}(\mathcal{K}(X))$	116
5.1. Cyclic and not cyclic graphs	120
5.2. Cyclic graph includes a +ve and -ve dominated vertex.	123
5.3. Not cyclic graph.	126
5.4. Cyclic graph with a dominated vertex.	127
5.5. Cyclic graph without dominated vertices.	127

List of Tables

5.1. Adjacency matrix.	135
5.2. Adjacency matrix.	139

List of Algorithms

1.	Strong collapse algorithm.	32
2.	Edge collapse algorithm [Functions part.]	46
3.	Edge collapse algorithm [Main algorithm].	47
4.	Edge collapse algorithm for matroids.	78
5.	Determine if an adjacency matrix can represent a cyclic graph . .	134
6.	Reorder a adjacency matrix to check if it can represent a directed cyclic graph. Main Part.	136
7.	Reorder an adjacency matrix to check if it represent a directed cyclic graph Function 1.	137
8.	Reorder an adjacency matrix to check if it represent a directed cyclic graph Function 2.	138
9.	How to determine the dominated vertices in a directed cyclic graph and then minimise the graph	141

Apéndice A

Resumo

A.1. Antecedentes

As nocións de homotopía, equivalencia de homotopía e tipo de homotopía son os conceptos centrais na Teoría da Homotopía. Desafortunadamente, dados dous espazos, é moi difícil decidir se son ou no homotópicamente equivalentes.

Nas décadas de 1930 e 1940, o enfoque deste problema era aplicar algún tipo de método combinatorio aos complexos simpliciais simbólicos (agora coñecido como complexos simpliciais abstractos). Seguindo este enfoque e o formalismo dado por J. W. Alexander no seu artigo *Combinatorial Analysis Situs* de 1926, en 1938 J.H.C. Whitehead iniciou, co seu traballo *Simplicial Spaces, nuclei and m-Groups*, unha serie de artigos moi importantes neste área. No primeiro introduciu a noción de **colapso elemental** e núcleo dun complexo simplicial e culminou a súa serie en 1950 introducindo a noción de homotopía simple dun tipo de espazos chamados CW, que definiu para solventar os problemas técnicos que atopou traballando con complexos simpliciais.

Na nosa historia, 1966 é un ano moi especial, porque se publicaron dous artigos seminais. No primeiro, debido a R. E. Stong *Finite Topological Spaces* destacou que vale a pena estudar os espazos finitos desde o punto de vista topolóxico. En particular, Stong comentou no seu artigo que dado un espazo topolóxico finito, X , cada punto $x \in X$ ten un conxunto aberto mínimo U_x que o contén (a intersección de cada conxunto aberto que contén x), esta idea permitiulle introducir unha orde parcial en X e definir os puntos lineais e

colineales (agora chamados **beat points**) como:

Definition (Stong 1966). *Sexa F un espazo topolóxico finito.*

(i) $x \in F$ é lineal se $\exists y > x$ tal que se $z > x$ entón $z \geq y$

(ii) $x \in F$ é colineal se $\exists y < x$ tal que se $z < x$ entón $z \leq y$

Stong demostrou que a eliminación e inclusión de beat points xera todas as equivalencias de homotopía entre espazos finitos (punteados). É dicir, dous espazos finitos son homotópicamente equivalentes se e só se pódense obter un doutro eliminando ou engadindo sucesivamente beat points.

O outro artigo de 1966 que nos interesa débese a Michael C. McCord (Singular Homology Groups And Homotopy Groups of Finite Topological Spaces). Nel, o autor relacionou espazos topolóxicos finitos co complexo simplicial finito dun xeito funtorial. Entón demostrou o seguinte teorema

Theorem (McCord 1966).

(i) *Para cada espazo topolóxico finito X existe un complexo simplicial finito $K(X)$ e unha equivalencia débil de homotopía $f : |K(X)| \rightarrow X$.*

(ii) *Para cada complexo simplicial finito K existe un espazo topolóxico finito X e unha equivalencia débil de homotopía $f : |K(X)| \rightarrow X$.*

Cabe souliñar que a idea principal das correspondencias no teorema anterior xa estaba contido nun artigo de 1937 onde P. S. Alexandroff, introduciu o "Diskrete Raume" (espazo discreto), agora coñecido como espazo de Alexandroff (A -espazo), que no é mais que un espazo topolóxico onde a intersección arbitraria de conxuntos abertos é tamén un conxunto aberto. En particular, un espazo topolóxico finito é un espazo de Alexandroff. Cabe destacar que 1966 foi tamén o ano de publicación do libro de Spanier "Topoloxía alxebrica", un dos libros mais leídos e citados na área.

En 2008, Jonathan Ariel Barmak, Elias Gabriel Minian no seu artigo "Tipo de homotopía simple e espazos finitos" fusionaron as ideas de Whitehead, Stong e McCord e presentaron unha nova aproximación á teoría de homotopía simple de poliedros utilizando espazos topolóxicos finitos e introducindo a seguinte noción de **weak beat points** como una xeneralización da noción de Stong de beat points.

Definition (Definición 3.2 Barmak-Minian 2008). *Sexa X un espazo T_0 finito. Diremos que $x \in X$ un weak beat point de X (ou un weak point para abreviar) se \hat{U}_x é contraíble ou \hat{F}_x é contraíble. No primeiro caso dicimos que x é un down weak point e no segundo, que x é un up weak point.*

onde \hat{U}_x (\hat{F}_x) indica os puntos de X maiores (menores) que x cando consideramos en X a orde previa dada pola topoloxía.

Este novo concepto permitiulles introducir o concepto de colapso dun espazo finito e demostraron que esta nova noción corresponde exactamente ao concepto de colapso simplicial introducido por Whitehead. Máis precisamente, demostraron que un colapso $X \searrow Y$ de espazos finitos induce un colapso simple $K(X) \searrow K(Y)$ dos seus complexos simpliciais asociados. Ademais, tamén demostraron que un colapso simple $K \searrow L$ induce un colapso $X(K) \searrow X(L)$ dos espazos finitos asociados. Deste xeito estableceron unha correspondencia un a un entre os tipos simples de homotopía de complexos simpliciais finitos e as clases de equivalencia simple de espazos finitos.

Pero con esta idea moi boa dos puntos débiles (weak points), ao usar métodos combinatorios, obtemos só unha mínima parte da homotopía dos poliedros cando pensamos que son espazos topolóxicos, polo que hai que atopar unha nova idea combinatoria. Non houbo que esperar moito tempo porque en 2012 ambos os autores (Minian e Barmak) conseguiron introducir o concepto de colapso forte, un tipo particular de colapso simple. A vantaxe de usar colapsos fortes é a existencia e a unicidade dos núcleos (propiedade que non teñen os núcleos introducidos por Whitehead en 1938)

O obxectivo principal, pero non o único, da miña investigación é comprender estes conceptos e melloralos na medida do posible. A topoloxía computacional a miña outra fonte de interese nesta tesis. A continuación explicarei un pouco de que se trata.

É obvio para calquera observador que a enorme mellora da tecnoloxía (ordenadores, sensores e comunicacións) nas últimas décadas, produciu e está a producir un gran impacto nas matemáticas. Hai moitos matemáticos que traballan na análise de datos, aprendizaxe automática e técnicas relacionadas. Sorprendentemente (ou non) este impacto tamén chegou a algo tan abstracto como a topoloxía alxébrica. Dende que comezou este século XXI hai un interese crecente na Análise Topolóxico de Datos e na Topoloxía Computacional. Para usar ordenadores para estudar espazos topolóxicos ou nubes de datos

con métodos topolóxicos é necesario codificalos como un obxecto combinatorio e o mellor candidato é o complexo simplicial. Así podemos asociar a unha nube de puntos un complexo simplicial e mediante a homoloxía persistente codificar a nube de puntos como un **código de barras** ou un **diagrama de persistencia** que permite extraer unha información interesante dos datos.

Pero un complexo simplicial asociado aos datos pode ser enorme e as computadoras non teñen o poder suficiente para xestionalo polo que os colapsos, como os que describimos nesta tese, pódense usar para reducir a complexidade do problema.

Así mesmo, as técnicas computacionais poden axudar a comprender un concepto matemático ou a facer exemplos ou "matemáticas experimentales", e neste sentido nesta tesis deseñei varios algoritmos para axudar ás investigacións a estudar varias propiedades do complexo simplicial ou de grafos (un complexo simplicial de dimensión 1).

Istos eran os dous temas que me interesaban cando comecei a miña tese e tiña os seguintes obxectivos e hipóteses.

A.2. Obxectivos e hipóteses

A noción de **beat point** introducida por Stong no contexto de espazos finitos pódese xeneralizar aos espazos de Alexandroff. Polo tanto, o obxectivo principal desta tese é:

Introducir e estudar a nova noción de **punto dominado** nun espazo de Alexandroff como xeneralización dos beat points.

En segundo lugar, teño outros dous obxectivos:

1. Probar varios novos resultados sobre matroides, complexos simpliciais e espazos de Alexandroff, a maioría relacionados coa noción de colapsabilidade.
2. Deseñar algoritmos útiles para facilitar o estudo da colapsabilidade dun complexo simplicial o nun grafo.

A.3. Metodoloxía

Nesta tese utilicei o método tradicional de investigación en matemáticas. Nunha primeira etapa estudamos en profundidade o que está publicado relacionado co tema de interese. Desta forma adquirese a destreza e as inspiracións dos expertos no tema. A continuación, coas destrezas adquiridas, téntase mellorar os resultados de acordo cos obxectivos que un se propuxo. É un proceso longo e complexo, con avances e retrocesos debidos aos erros detectados nas novas demostracións ou no inadecuado dos novos conceptos que se quere introducir. Este debate interno contrástase e modula coa opinión do director da tese doutoral e outros matemáticos interesados no tema. Aos poucos vaise construíndo unha pequena teoría matemática como a que plasmoo neste documento.

A.4. Conclusiones

Introduzo e estudo a noción de punto P-dominado nun espazo de Alexandroff como unha xeneralización dos beat points (ver capítulo 4) e demostro que é unha boa xeneralización dos dito concepto.

Os outros dous obxectivos conséguense deseñando varios algoritmos (vease os capítulos 2, 3 e 4) e probando varios resultados relacionados coa colapsibilidade, os espazos de Alexandroff e os matroides como podense ver ao longo desta tese. A continuación explicase con máis detalle as conclusións presentadas en cada capítulo.

A.5. Resumo dos contidos por capítulos

No primeiro capítulo introduciremos algúns preliminares sobre a homotopía e o tipo de homotopía. Estudaremos estes dous conceptos sobre unha estrutura interesante chamada *complexo simplicial*. Estudaremos o complexo simplicial de dúas formas: en primeiro lugar de forma xeométrica onde un complexo simplicial é un espazo topolóxico construído "pegando" puntos, arestas, triángulos e as súas contrapartes n-dimensionais e en segundo lugar nunha combinatoria, onde o complexo simplicial abstracto é unha familia de conxuntos, chamados simplices, que está pechada baixo a acción de tomar subconxuntos.

Estudamos as relacións entre ambas as definicións e como pasamos dunha a outra. Tamén lembraremos que certas aplicacións chamados *simplicial maps* entre dous complexos simpliciais (combinatorios) dannos aplicacións continuas entre os complexos simpliciais xeométricos asociados. Usando o concepto de homotopía podemos poñer dúas funcións entre espazos topolóxicos na mesma equivalencia clase, esta idea pódese transferir a complexos simpliciais usando a noción de *clases de contigüidade* que dá unha forma construtiva de homotopía aplicable a mapas simpliciais a nivel de realizacións xeométricas.

No segundo capítulo, lembramos un procedemento inventado por J. H. C. Whitehead en 1938, que é o primeiro intento de clasificar homotópicamente os complexos simpliciais en clases equivalentes. A súa famosa estratexia foi minimizar e simplificar complexos simpliciais finitos mediante unha secuencia de simples eliminando chamada *caras libres* para acadar un complexo mínimo chamado *o núcleo*, esta operación chamado *O Colapso*, asume que os complexos simples pertencen ao mesmo clase equivalente se teñen núcleos isomórficos. Pero este intento non éxito xa que hai moitos núcleos do mesmo complexo dependendo dos pasos de eliminar as caras libres e eses núcleos non son únicos salvo isomorfismo,

En 2012, Barmak e Miniam lograron aplicar esta idea, para minimizar e simplificar complexos simpliciais finitos usando unha estratexia chamada *colapso forte* que trataremos na Sección 2.2. dependendo de eliminar un *vértices dominados*. Un terceiro procedemento chamado *contraccións de aresta* foi estudado inicialmente en topoloxía por Walkup en 1970. Neste capítulo compararemos os tres tipos.

Para terminar el capítulo na sección 2.3 e na sección 2.5, indicaremos dous algoritmos para particionar os simples máximos que cobren o complexo simplicial en subcomplexos, cada subcomplexo pode colapsar forte/colapso de bordo ata un punto. o número destes subcomplexos será un límite superior de *Gscat/Ecat*. Cada algoritmo mostra unha estratexia diferente para realizar o colapso forte, e cada algoritmo está codificado usando o programa Python, algúns exemplos famosos aplícanse cos programas.

O terceiro capítulo está dedicado a estudar as construcións do capítulo dous nos matroides. Lembre que os matroides foron introducidos e nomeados por H. Whitney en 1935 como xeneralización abstracta de matrices. A súa realización como complexo simplicial é moi sinxela desde o punto de vista homotópico xa que son homotópicos equivalentes a cuñas de esferas, pero segue sendo interesante dende o punto de vista "homotópico combinatorio". Demostramos que as clases de matroides están pechadas ao borrar un punto ou contraer una aresta. Tamén demostramos o seguinte

Theorem. 3.1.3 *Se a intersección do conxunto de máximas dun matroide é non baleira, entón non podemos colapsar de maneira fuerte dicho matroide.*

Sexa $\mathcal{B}(M) = \{F_i : i \in \Delta\}$ a base dun matroid M . Si $\bigcap_{\mathcal{B}(M)} F_i = \phi$, entón M no ten vértices dominados, o que significa que M é un núcleo.

Theorem. 3.1.5 *Sexa M un matroide con base $\mathcal{B}(M) = \{F_i : i \in \Delta\}$ tal que $|F_i| = n$, e sexa e un vértice in $V(M)$, entón as seguintes afirmacións son equivalentes:*

- a. $e \in \bigcap_{i \in \Delta} F_i$.
- b. $M \searrow \searrow \{e\}$.
- c. $M \searrow \{e\}$.
- d. *Existe unha cara libre.*
- e. *Existen vértices dominados.*

Polo tanto, chegamos á conclusión de que cada matroide é un núcleo ou é fortemente colapsable ata un punto. Na parte d. para calquera F_i máximo, $(F_i, F_i \setminus e)$ xera unha cara libre.

No Teorema 3.1.4. demostramos que as seguintes afirmacións son equivalentes:

- a. A intersección dos conxuntos maximais non está baleira, digamos e , pertence a esta intersección.

- b. O matroide pode colapsar ata o punto e
- c. O matroide pode colapsar forte ata o punto e
- d. Existe unha cara libre.
- e. Existe un vértice dominado.

No apartado 3.3. mostramos que ao contraer unha aresta dun matroide dáse un novo matroide. entón mostramos que o teorema 3.1.4 non é certo para o "edge contraction". terminaremos con un algoritmo para particionar os máximos de matroides en submatroides fortemente colapsables.

Tamén este algoritmo está codificado usando o programa Python.

O capítulo catro é o máis grande desta tese e está dedicado a estudar a colapsabilidade en espazos de Alexandroff non finitos. Unha relación binaria reflexiva e transitiva é chamada *unha preorde*. Unha pre orde é *unha orde parcial se ademais é antisimétrica*. Chamaremos (*poset*) a un conxunto con unha preorder Tamén un *espazo topolóxico de Alexandroff* é unha topoloxía onde a intersección de calquera familia de conxuntos abertos é aberta.

Se temos algún espazo topolóxico, podemos asociar unha relación de preorde sobre o conxunto dos abertos (e decir sobre a súa topoloxía) usando a inclusión. Se esta topoloxía é espazo de Alexandroff, a preorde definida chámase *preorde de especialización*, e se a topoloxía é un espazo T_0 entón a súa preorder é un poset. En realidade, hai unha equivalencia entre as preordes e as topoloxías de Alexandroff. McCord mostra a cada poset, pódese asociar un complexo simplicial abstracto chamado *o complexo da orde*. E a cada complexo simplicial pódese asociar un poset que é débilmente homotópico equivalente a el.

Stong [35] expón os conceptos de eliminar un punto especial chamado *beat points* do espazo mantendo o seu tipo de homotopía, introduciu o concepto de *núcleos de espazos finitos*, entón May e Kukiela xeneralizan o seu resultado nun espazo infinito de Alexandroff. Minimizan o espazo mediante unha secuencia de pasos, en cada paso eliminan un único "beat point". Chamamos a esta operación un *B-collapse*. Kukiela clasifica a clase de espazos infinitos de Ale-

xandroff e demostra os resultados que mostran que algúns espazos localmente finitos pódense deformar por retracción e de maneira forte a un núcleo.

Definition. 4.2.2 *Sexa (X, \leq) un espazo de Alexandroff e $a, b \in X$ tal que $a \not\leq b$*

1. *dicimos que a está p^+ dominado por b , se $c \geq a$ implica $c \sim b$. Neste caso denotaremos A_{ab}^+ o conxunto $\{s \in X : a \leq s < b\}$.*
2. *dicimos que b está p^- dominado por a , se $c \leq b$ implica $c \sim a$. Neste caso denotaremos A_{ab}^- o conxunto $\{s \in X : a < s \leq b\}$.*

Un subconxunto A de X chámase conxunto de contracción se existen dous puntos $a, b \in X$ tal que a é p^+ dominado por b , polo tanto, $A = A_{ab}^+$ ou b é p^- dominado por a , polo tanto $A = A_{ab}^-$.

Nesta definición ampliaremos a definición de "beat points" (onde eliminamos un só punto en cada paso) a unha nova definición chamada p -dominado (onde podemos eliminar nun paso do espazo o conxunto de contraccións (quizais infinitos puntos)), chamámoslle a esta operación P -colapso. O espazo sen puntos dominados por P - chamado P -núcleo.

Theorem. 4.2.9 *Sexa (X, \leq) un espazo topolóxico de Alexandroff, e supoña que a é p^+ dominado por b , cun conxunto de contracción A_{ab}^+ , entón $X - A_{ab}^+$ é unha forte retracción de deformación de X . Do mesmo xeito, a retracción xerada ao eliminar p^- punto dominado e a retracción xerada pola expansión P elemental, ambos son tamén retraccións de forte deformación.*

Na sección 4.3, discutimos as relacións entre os beat points superior/abaixo e os puntos dominados por p^+/p^- a través do noso teorema principal que mostra que as operacións de colapso P e B -colapso son similares se o espazo só contén cadeas finitas:

Theorem. 4.3.5 *No espazo de Alexandroff X . Cada conxunto de contracción de cadea finita A^+ pode representarse mediante secuencias de B^+ -colapsos en pasos de ω como máximo, onde ω é o primeiro ordinal. Do mesmo xeito, cada conxunto de contracción A^- pode representarse mediante secuencias de B^- -colapsos eliminando os "down beat points".*

Ademais indicamos o exemplo 4.3.5. para mostrar un espazo contén cadeas infinitas que podemos colapsar P un espazo a un punto pero non podemos colapsar B algúns puntos deste espazo. No exemplo 4.3.6. Mostramos un espazo no que podemos colapsar P a un punto e tamén podemos colapsar $B+$ ata un punto, aínda que o espazo conteña cadeas infinitas, finalmente no exemplo 4.3.7. Mostramos que un espazo contén cadeas infinitas e podemos colapsar P ata un punto. pero o espazo non contén puntos ascendentes ou descendentes, polo que non podemos iniciar puntos de colapso B , polo que o espazo é un núcleo no sentido de Stong.

Lembre, $C(X, Y)$ denota o espazo de todos os mapas continuos de X a Y na topoloxía compacta-aberta. Kukiela presenta as clases de *camiños finitos* e espazos de camiños acotados e indica o seguinte teorema 4.4.5.

Se un espazo é un *C -espazo de camiño finito central*, entón non hai mapa $C(X, X)$ homotópico a id_X distinto de id_X .

Denunciamos na Definición 4.4.6. un espazo chamado *espazos limitados*, baixo este espazo podemos xeneralizar o teorema anterior

Theorem. 4.4.10 *Sexa X un espazo acotado de C -núcleo, se un dos seguintes cumpre*

- X ten un límite finito.
- $C(X, X)$ é Alexandroff.

non hai mapa en $C(X, X)$ homotópico a id_X distinto de id_X .

Ademais, dous espazos finitos son homotópicamente equivalentes se e só se os seus núcleos son homeomórficos. Tamén indicamos unha proba máis sinxela e general.

En la sección 4.5 discutimos algunas formas de convertir un espacio topológico en un complejo simplicial y viceversa.

No capítulo 5 interesáronos nun tipo especial de grafos chamados *grafos cíclicos* introducidos por Adamaszek, Michael, e Henry Adams. No seu traballo introducen a noción de *-vértice dominado*. Enunciamos unha definición casi

análoga chamada *+ve vértice dominado* e demostramos que If temos un grafo cíclico. Se temos un gráfico cíclico, entón:

Existe un vértice dominado -ve \Leftrightarrow Existe un vértice dominado +ve.

Ademais, o número de vértices dominados +ve é igual ao número de -ve vértices dominados.

entón chamamos á definición de grafo non dirixido, que en realidade é un complexo simplicial de 1 dimensión, e estudamos a relación entre os vértices dominados tanto nos grafos dirixidos coma nos non dirixidos.

Na sección 5.2 mostramos que se temos un grafo dirixido podemos construír un conxunto de preorde *por alcanzabilidade*, na outra dirección, se temos un poset podemos construír un grafo dirixido, entón estudamos a relación entre os vértices dominados. en gráficos dirixidos e os puntos dominados por p no espazo de ordes previas de correspondencia e viceversa.

entón estudamos a propiedade dunha grafoa especial denotada por \overrightarrow{C}_n^k Na sección 5.3 indicamos que os algoritmos responden ás seguintes preguntas:

1. Se temos unha grafo cunha orde nos vértices, como podemos detectar se isto ordenar o rendemento a un grafo cíclico usando a matriz de adxacencia?
2. Se temos algunha matriz con 0 ou 1 entradas, podemos reordenar esta matriz para detectar se pode representar un grafo cíclico ou non?
3. Como podemos determinar os vértices dominados a partir da matriz de adxacencia? e entón determina o núcleo.

Bibliografía

- [1] Islam, Taha 0xIslamTaha. <https://gist.github.com/0xIslamTaha>
- [2] Adamaszek, Michal, and Henry Adams. The Vietoris-Rips Complexes of a Circle. *Pacific Journal of Mathematics*, vol. 290, no. 1, July 2017, pp. 140, <https://doi.org/10.2140/pjm.2017.290.1>.
- [3] Amit Kumar, Paul, and Sen Debasis. Simplicial and Combinatorial Versions of Higher Symmetric Topological Complexity. *Research Gate*, 2021, www.researchgate.net/publication/350720371_Simplicial_and_combinatorial_versions_of_higher_symmetric_topological_complexity.
- [4] Attali, Dominique, et al. Efficient Data Structure for Representing and Simplifying Simplicial Complexes in High Dimensions. *International Journal of Computational Geometry and Applications*, vol. 22, no. 04, Aug. 2012, pp. 279-303, <https://doi.org/10.1142/s0218195912600060>.
- [5] Aleksandrov, A D; Berestovskii, V N Nikolaev, I G *Generalized Riemannian spaces*. Russian Mathematical Surveys. 41 (3): 1–54. 1986.
- [6] Barmak, Jonathan A. *Algebraic Topology of Finite Topological Spaces and Applications*. Springer, 2011.
- [7] Barmak, Jonathan Ariel, and Elias Gabriel Minian. Strong Homotopy Types, Nerves and Collapses. *Discrete and Computational Geometry*,

- vol. 47, no. 2, May 2011, pp. 301-28, <https://doi.org/10.1007/s00454-011-9357-5>.
- [8] Blumberg, Andrew J., and Michael A. Mandell. Quantitative Homotopy Theory in Topological Data Analysis. *Foundations of Computational Mathematics*, vol. 13, no. 6, Oct. 2013, pp. 885-911, <https://doi.org/10.1007/s10208-013-9177-5>.
- [9] Boissonnat, Jean-Daniel, Pritam Siddharth, et al. Strong Collapse and Persistent Homology. *Journal of Topology and Analysis*, Apr. 2021, pp. 1-29, <https://doi.org/10.1142/s1793525321500291>.
- [10] Boissonnat, Jean-Daniel, and Clement Maria. The Simplex Tree: An Efficient Data Structure for General Simplicial Complexes. *Algorithmica*, vol. 70, no. 3, May 2014, pp. 406-27, <https://doi.org/10.1007/s00453-014-9887-3>.
- [11] Boissonnat, Jean-Daniel, and Siddharth Pritam. Computing Persistent Homology of Flag Complexes via Strong Collapses. *Dagstuhl Research Online Publication Server*, edited by Gill Barequet and Yusu Wang, vol. 129, Schloss Dagstuhl-Leibniz-Zentrum fuer Informatik, 2019, pp. 55:1-15, <https://doi.org/10.4230/LIPIcs.SoCG.2019.55>.
- [12] Boissonnat, Jean-Daniel, and Siddharth Pritam. Edge Collapse and Persistence of Flag Complexes. *International Symposium on Computational Geometry*, Jun 2020, Switzerland. ff10.4230.
- [13] Bromssen, Erik von. Computing Persistent Homology in Parallel with a Functional Language. *Www.semanticscholar.org*, 2021, https://odr.chalmers.se/bitstream/20.500.12380/302628/1/Master_thesis_Erik_von_Bromssen.pdf
- [14] Cohen M.M, *A Course in Simple Homotopy Theory*, Springer-Verlag, New York, 1970.
- [15] Chen, Xi. CORES of ALEXANDROFF SPACES. *Www.semanticscholar.org*, 2015

- [16] Ehrenborg, Richard, and Gábor Hetyei. The Topology of the Independence Complex. *European Journal of Combinatorics*, vol. 27, no. 6, Aug. 2006, pp. 906-23, <https://doi.org/10.1016/j.ejc.2005.04.010>.
- [17] D. Fernández-Tertero, E. Macías-Virgós, and J. A. Vilches. Lusternik Schnirelmann category of simplicial complexes and finite spaces. *Topology Appl.*, 194:37–50, 2015.
- [18] Dominique Attali, André Lieutier, and David Salinas. Vietoris-rips complexes also provide topologically correct reconstructions of sampled shapes. *Computational Geometry*, 46(4):448– 465, 2013.
- [19] Farley, Jonathan David. Sequences of Chain-Complete Posets. *Discrete Mathematics*, no. 167-168, 1997, pp. 271-96. [https://doi.org/10.1016/s0012-365x\(96\)00234-8](https://doi.org/10.1016/s0012-365x(96)00234-8).
- [20] Ferrario, Davide L., and Renzo A. Piccinini. *Simplicial Structures in Topology*. CMS Books in Mathematics, Springer New York, 2011, <https://doi.org/10.1007/978-1-4419-7236-1>. [Theorem II.2.7]
- [21] Ghorbani, Vahid. Introduction to Matroid Theory. *ResearchGate*, 2017, www.researchgate.net/publication/322131760_Introduction_to_Matroid_Theory.
- [22] Hatcher, Allen. *Algebraic Topology*. Cambridge University Press, 2002.
- [23] Heras, Jonathan, et al. Computing Persistent Homology within Coq/SSReflect. *ACM Transactions on Computational Logic*, vol. 14, no. 4, Nov. 2013, pp. 1-16, <https://doi.org/10.1145/2528929>.
- [24] Horak, Danijela, et al. Persistent Homology of Complex Networks. *Journal of Statistical Mechanics: Theory and Experiment*, vol. 2009, no. 03, Mar. 2009, p. P03034, <https://doi.org/10.1088/1742-5468/2009/03/p03034>.
- [25] Jiri Matousek. LC Reductions Yield Isomorphic Simplicial Complexes. *Contributions to Discrete Mathematics*, vol. 3, no. 2, 2019, <https://doi.org/10.11575/cdm.v3i2.61933>.

- [26] Jonsson, Jakob. Introduction to Simplicial Homology (Work in Progress). 2011, <https://people.kth.se/~jakobj/doc/homology/homology.pdf>
- [27] Klappenecker, A. Noetherian Induction. *semanticscholar*, 2008, www.semanticscholar.org/paper/Noetherian-Induction-Klappenecker/62b91469bbb0a6f9f568a6d223931525ebd58b24.
- [28] Kukiela, Michal Jerzy. On Homotopy Types of Alexandroff Spaces. *Order*, vol. 27, no. 1, Oct. 2009, pp. 9-21. <https://doi.org/10.1007/s11083-009-9134-8>.
- [29] Macias-Virgos. Fernandez-Ternero., et al. Lusternik-Schnirelmann Category of Simplicial Complexes and Finite Spaces. *Topology and Its Applications*, vol. 194, Oct. 2015, pp. 37-50, <https://doi.org/10.1016/j.topol.2015.08.001>.
- [30] May, J. P. Finite Spaces and Larger Contexts. 2016, math. <https://math.uchicago.edu/~may/FINITE/FINITEBOOK/FINITEBOOKCollatedDraft.pdf>.
- [31] May, J.P. Finite spaces and simplicial complexes, Notes for REU 2003.
- [32] McCord, Michael C. Singular Homology Groups and Homotopy Groups of Finite Topological Spaces. *Duke Mathematical Journal*, vol. 33, no. 3, Sept. 1966. <https://doi.org/10.1215/s0012-7094-66-03352-7>.
- [33] Michał Adamaszek and Henry Adams, *Vietoris-Rips complexes of a circle*, arXiv:1503.03669, 2015
- [34] Milnor, J. Whitehead Torsion. *Bulletin of the American Mathematical Society*, vol. 72, no. 3, 1966, pp. 358-426, <https://doi.org/10.1090/s0002-9904-1966-11484-2>.

- [35] Mock, Andrea, and Ismar Volic. Political Structures and the Topology of Simplicial Complexes. *Mathematical Social Sciences*, vol. 114, Nov. 2021, pp. 39-57, <https://doi.org/10.1016/j.mathsocsci.2021.09.004>.
- [36] Munkres, James R. Elements of Algebraic Topology. *Cambridge Perseus Publ*, 1997. <://people.dm.unipi.it/benedett/MUNKRES-ETA.pdf>
- [37] Nadathur, Prerna. An Introduction to Homology. 2007, www.math.uchicago.edu/~may/VIGRE/VIGRE2007/REUPapers/INCOMING/Project.pdf.
- [38] Osaki. *Reduction of finite topological spaces*. Interdisciplinary Information Sciences 5, 149-155, 1999
- [39] P.S. Alexandroff, *Diskrete Räume*, Math. Sb. 2 501–518, 1937.
- [40] Rhodes, John L., and Pedro V. Silva. *Boolean Representations of Simplicial Complexes and Matroids*. Springer, 2015.
- [41] Sakai, Katsuro, and Hanbiao Yang. The Box Topology of Infinite Simplicial Complexes. *Tsukuba Journal of Mathematics*, vol. 36, no. 2, Jan. 2013, <https://doi.org/10.21099/tkbjm/1358777002>.
- [42] Spanier, Edwin H. *Algebraic Topology*. Mcgraw Hill, 1976.
- [43] Speer, Timothy. Short Study of Alexandroff Spaces. *arXiv*. 2007. <https://arxiv.org/pdf/0708.2136.pdf>
- [44] Stong, R. E. Finite Topological Spaces. *Transactions of the American Mathematical Society*, vol. 123, no. 2, 1966, pp. 325-40, www.ams.org/journals/tran/1966-123-02/S0002-9947-1966-0195042-2/S0002-9947-1966-0195042-2.pdf.
- [45] Switzer, Robert M. *Algebraic Topology – Homotopy and Homology*. Springer Berlin Heidelberg, 1975, <https://doi.org/10.1007/978-3-642-61923-6>. **Lemma 6.8, p. 76**

- [46] S. Zhou, *Types of homotopy in simplicial complexes and finite space* math.uchicago.edu, 2020
- [47] Whitehead, J.H.C. *Simplicial spaces, nuclei and m-groups*, Proceedings of the London Mathematical Society 45, pp 243–327, 1938
- [48] Whitehead, J.H.C. *On incidence matrices, nuclei and homotopy types*, Ann. of Math. 42 pp 1197–1239, 1941
- [49] Whitehead, J.H.C. *Simple homotopy types*, Amer. J. Math. 72 1–57, 1950
- [50] Tammo Tom Dieck. Algebraic Topology. *European Mathematical Society*, 2010. <https://www.maths.ed.ac.uk/~v1ranick/papers/diecktop.pdf>
- [51] Whitney, Hassler. **On the Abstract Properties of Linear Dependence.** *American Journal of Mathematics*, vol. 57, no. 3, July 1935, p. 509, <https://doi.org/10.2307/2371182>.
- [52] Xiao, Mingyu. **A Note on Vertex Cover in Graphs with Maximum Degree 3.** *Lecture Notes in Computer Science*, 6196, Springer, 2010, pp. 150-59, https://doi.org/10.1007/978-3-642-14031-0_18.
- [53] SageMath, **a free open-source mathematics software system** <https://www.sagemath.org/>



In 1950 when JHC Whitehead introduced the idea of elementary collapse of simplicial complex space and the simple homotopy type. In 2012 Barmak and Minian return to the topic and develop the theory of strong collapse of simplicial complexes, which has interesting applications to collapsibility problems.

In this thesis we first review both concepts and a third one - edge collapse- and explore their consequences on matroid (a special kind of simplicial complexes). Secondly, we study a generalization of the idea of strong collapse to (non-finite) Alexandroff spaces. Finally, we present several algorithms to facilitate the exploration of all these concepts in the case of finite simplicial complexes and directed graphs.